



**SKOOT•HT**

DP0029 Rev 03.4

Automated Scanner

---

## SAFETY WARNINGS / PRECAUTIONS

### KEEP THIS MANUAL – DO NOT LOSE

THIS MANUAL IS PART OF THE **SKOOT HT** SYSTEM AND MUST BE RETAINED FOR THE LIFE OF THE PRODUCT. PASS ON TO SUBSEQUENT OWNERS.

Ensure any amendments are incorporated with this document.



**WARNING!** The **SKOOT HT** is designed for a specific use. Using the **SKOOT HT** outside of its intended use is dangerous. Failure to comply with the warnings, instructions, and specifications in this manual could result in **SEVERE INJURY** or **DEATH**. Read and understand this manual before using.



**WARNING! FALLING OBJECT HAZARD.** The area below a crawler must be kept clear at all times. A clearly marked **NO ENTRY ZONE** must be cordoned off directly below the area of crawler operation.

*(see No Entry Fall Zone on page 28 for additional details)*

**WARNING!** Do **NOT** operate or place crawler on a surface higher than 2 m (6 ft) without a proper tether held taut at all times.

*(see Tether Requirements and Attachment on page 29 for additional details)*



**WARNING! ELECTRICAL CORDS CAN BE HAZARDOUS.**

Misuse can result in **FIRE** or **DEATH** by **ELECTRICAL SHOCK**. Inspect thoroughly before each use. Do **NOT** use if damaged. Do **NOT** use when wet. Keep away from water. Do **NOT** drive, drag or place objects over cord.



**WARNING!** Do **NOT** operate scanner in an explosive environment. Do **NOT** operate scanner in the presence of volatile substances.





**WARNING! MAGNETIC MATERIAL.** The wheels of the crawler produce an extremely strong magnetic field which may cause failure or permanent damage to items such as watches, memory devices, CRT monitors, medical devices or other electronics.



Tools, magnets and metal objects can cut, pinch or entrap hands and fingers. **HANDLE WITH CARE.**

People with pacemakers or ICD's must stay at least 25 cm (10 in) away.

**WARNING! MAGNETIC MATERIAL.** The handheld controller produces a strong magnetic field which may cause failure or permanent damage to items such as watches, memory devices, CRT monitors, medical devices or other electronics.

People with pacemakers or ICD's must stay at least 10 cm (4 in) away.

**WARNING! MAGNETIC MATERIAL.** The handheld controller produces a strong magnetic field which may cause failure or permanent damage to items such as watches, memory devices, CRT monitors, medical devices or other electronics.

People with pacemakers or ICD's must stay at least 10 cm (4 in) away.



**WARNING! HOT SURFACE.** The **SKOOT HT** crawler may reach temperatures that may cause burns if contacted with bare skin. Wear heat resistant safety gloves when handling.



**WARNING!** The coolant used in this product contains a 50/50 blend of ethylene glycol based automotive antifreeze and water. Consult the MSDS for hazards associated with the use and handling of this coolant.



**WARNING! FLAMMABLE.** The coolant used in this product contains a 50/50 blend of ethylene glycol based automotive antifreeze and water which, in very specific conditions, may be flammable. If a leak develops, remove the **SKOOT HT** from the hot surface immediately. Keep ignition sources away from coolant vapors. Do not use system on surfaces >350°C (662°F).



**WARNING! LASER RADIATION.** The battery powered optical guide contains a Class 1M laser. Do not view directly with optical instruments.



**WARNING!** If this product is to be used with any Child Products listed in (*Chapter 2.3*), be sure to read and comply with the warnings, instructions, and specifications in the Child Product's User Manual(s).



**WARNING! DO NOT DISASSEMBLE.** No user-serviceable parts. Disassembling any of the components in this product, beyond the instructions in this user manual, could void the regulatory certifications and/or effect the safety of the product.



**CAUTION! DO NOT** operate the **SKOOT HT** crawler on an inspection surface which is electrically connected to a component that is being welded.



**CAUTION! DO NOT DISCONNECT UNDER LOAD.** Shut off power before connection or disconnecting. Permanent damage to electronics could occur.

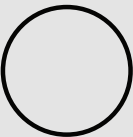
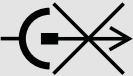

**OFF.** This symbol indicates an off button.



The WEEE symbol indicates that the product must not be disposed of as unsorted municipal waste, but should be collected separately.

(see *Disposal* on page 132 for additional details).

---

# TABLE OF CONTENTS

|          |   |          |
|----------|---|----------|
| <b>1</b> | <b>Identification</b> .....   | <b>1</b> |
|          | 1.1. Product Brand .....  | 1        |
|          | 1.2. Manufacturer .....   | 1        |
|          | 1.3. Compliance Declarations .....                                  | 1        |
|          | 1.3.1. ISED Emissions Compliance (Canada).....                      | 1        |
|          | 1.3.2. FCC Suppliers Declaration of Conformity (United States)..... | 1        |
|          | 1.3.3. European Union CE Declarations .....                         | 2        |
|          | 1.3.4. UKCA Declarations .....                                      | 2        |
| <b>2</b> | <b>Product Specifications</b> .....                                 | <b>3</b> |
|          | 2.1. Base SKOOT HT System Specifications .....                      | 3        |
|          | 2.1.1. Intended Use .....   | 3        |
|          | 2.1.1.1 Operating Limits .....                                      | 4        |
|          | 2.1.1.2 Operating Environment .....                                 | 5        |
|          | 2.1.1.3 User .....  | 5        |
|          | 2.1.2. Unintended Use .....   | 6        |
|          | 2.1.3. Dimensions and Weight .....                                  | 7        |
|          | 2.1.4. Power Requirements .....                                     | 8        |
|          | 2.1.5. Environmental Sealing .....                                  | 8        |
|          | 2.1.6. Performance Specifications .....                             | 9        |
|          | 2.1.7. Encoder Interface Specifications .....                       | 9        |
|          | 2.2. Compatible Components .....                                    | 10       |
|          | 2.2.1. Low Profile Probe Holder Frame .....                         | 10       |
|          | 2.2.1.1 Intended Use .....  | 10       |
|          | 2.2.1.2 Operating Limits .....                                      | 10       |
|          | 2.2.2. Vertical Probe Holder Frame .....                            | 10       |
|          | 2.2.2.1 Intended Use .....  | 10       |
|          | 2.2.2.2 Operating Limits .....                                      | 11       |
|          | 2.2.3. Pivoting Probe Holder Frame .....                            | 11       |
|          | 2.2.3.1 Intended Use .....  | 11       |
|          | 2.2.3.2 Operating Limits .....                                      | 11       |
|          | 2.2.4. Frame Bar .....  | 11       |
|          | 2.2.4.1 Intended Use .....  | 11       |
|          | 2.2.4.2 Operating Limits .....                                      | 11       |
|          | 2.2.5. Battery Powered Optical Guide .....                          | 12       |
|          | 2.2.5.1 Intended Use .....  | 12       |
|          | 2.2.5.2 Operating Environment .....                                 | 12       |
|          | 2.2.5.3 Power Requirements .....                                    | 12       |

|         |                         |    |
|---------|-------------------------|----|
| 2.2.5.4 | Environmental Sealing   | 12 |
| 2.3.    | Child Products          | 13 |
| 2.3.1.  | Motorized Couplant Pump | 13 |
| 2.3.2.  | Motorized Raster Arm HT | 13 |
| 2.3.3.  | Battery Kit             | 13 |

### 3

|             |                        |    |
|-------------|------------------------|----|
| Definitions | 14                     |    |
| 3.1.        | Definitions of Symbols | 14 |
| 3.2.        | Safety Symbols         | 14 |
| 3.3.        | Safety Signal Words    | 15 |

### 4

|                   |   |    |
|-------------------|---|----|
| System Components | 16  |    |
| 4.1.              | Base System Components                            | 16 |
| 4.1.1.            | SKOOT • HT (Crawler)                              | 16 |
| 4.1.1.1.          | Off Button  | 16 |
| 4.1.2.            | System Controller                                 | 17 |
| 4.1.2.1.          | AC/DC Power Supply                                | 18 |
| 4.1.3.            | SKOOT HT Umbilical                                | 19 |
| 4.1.4.            | Handheld Controller                               | 19 |
| 4.1.5.            | Manipulation Handle                               | 20 |
| 4.1.6.            | Auxiliary Cables                                  | 20 |
| 4.1.7.            | J300 Encoder Cable                                | 20 |
| 4.1.8.            | Irrigation Kit                                    | 20 |
| 4.1.9.            | High Temperature Cable Management, Threaded Mount | 21 |
| 4.1.10.           | Cooler  | 21 |
| 4.1.11.           | Hoses   | 21 |
| 4.1.12.           | Tools   | 21 |
| 4.1.13.           | Cases   | 21 |
| 4.2.              | Compatible Components                             | 22 |
| 4.2.1.            | Low Profile Probe Holder Frame                    | 22 |
| 4.2.2.            | Vertical Probe Holder Frame                       | 22 |
| 4.2.3.            | Pivoting Probe Holder Frame                       | 22 |
| 4.2.4.            | Frame Bar   | 22 |
| 4.2.5.            | Slip Joint Probe Holder                           | 23 |
| 4.2.6.            | Vertical Probe Holder                             | 23 |
| 4.2.7.            | Heavy Duty Vertical Probe Holder                  | 23 |
| 4.2.8.            | Corrosion Thickness Probe Holder HT               | 23 |
| 4.2.9.            | SKOOT HT Extension Kit                            | 24 |
| 4.2.10.           | Battery Powered Optical Guide                     | 24 |
| 4.2.11.           | Encoder Adapter                                   | 24 |
| 4.2.12.           | Battery   | 24 |

|         |                                 |    |
|---------|---------------------------------|----|
| 4.2.13. | Charger and Power Adapter ..... | 25 |
| 4.2.14. | Tools .....                     | 25 |
| 4.2.15. | Cases .....                     | 25 |
| 4.3.    | Child Products .....            | 26 |
| 4.3.1.  | Motorized Couplant Pump.....    | 26 |
| 4.3.2.  | Motorized Raster Arm HT.....    | 26 |
| 4.3.3.  | Battery Kit.....                | 26 |
| 4.4.    | Tools .....                     | 27 |
| 4.4.1.  | Included Tools .....            | 27 |
| 4.4.2.  | Optional Tools .....            | 27 |

**5**

**Preparation for Use .....28**

|         |  |    |
|---------|--|----|
| 5.1.    | Transportation .....                     | 28 |
| 5.2.    | Preparation for Safe Use .....           | 28 |
| 5.2.1.  | No Entry Fall Zone .....                 | 28 |
| 5.2.2.  | Tether Requirements and Attachment ..... | 29 |
| 5.3.    | Preparation of Inspection Surface .....  | 30 |
| 5.4.    | System Connectivity .....                | 31 |
| 5.5.    | Configurations .....                     | 33 |
| 5.5.1.  | Crawler with Multiple Probe Holders..... | 33 |
| 5.5.1.1 | Low Profile Probe Holder Frame .....     | 33 |
| 5.5.1.2 | Vertical Probe Holder Frame .....        | 35 |
| 5.5.1.3 | Pivoting Probe Holder Frame .....        | 37 |
| 5.5.1.4 | Flange .....                             | 39 |
| 5.6.    | Crawler .....                            | 41 |
| 5.6.1.  | Swivel Mount .....                       | 41 |
| 5.6.2.  | Umbilical .....                          | 42 |
| 5.6.3.  | Handle .....                             | 43 |
| 5.6.4.  | Off Button .....                         | 44 |
| 5.6.5.  | Cable Retainer .....                     | 45 |
| 5.6.6.  | Manipulation Handle .....                | 45 |
| 5.6.7.  | Quick Connect Fitting .....              | 46 |
| 5.7.    | Handheld Controller .....                | 46 |
| 5.7.1.  | Magnetic Mounts .....                    | 46 |
| 5.8.    | Probe Holder .....                       | 47 |
| 5.8.1.  | Heavy Duty Vertical Probe Holder .....   | 47 |
| 5.8.1.1 | Probe Holder Setup .....                 | 47 |
| 5.8.1.2 | Probe Holder Vertical Adjustment.....    | 49 |
| 5.8.1.3 | Probe Holder Left/Right Conversion ..... | 50 |
| 5.8.1.4 | Probe Holder 90° Adjustment.....         | 51 |
| 5.8.2.  | Vertical Probe Holder .....              | 52 |

|         |   |    |
|---------|---|----|
| 5.8.2.1 | Probe Holder Setup .....  | 52 |
| 5.8.2.2 | Probe Holder Vertical Adjustment .....                              | 53 |
| 5.8.2.3 | Probe Holder Transverse Adjustment .....                            | 54 |
| 5.8.2.4 | Probe Holder Longitudinal Adjustment .....                          | 55 |
| 5.8.2.5 | Probe Holder Left/Right Conversion .....                            | 56 |
| 5.8.3.  | Slip Joint Probe Holder .....                                       | 58 |
| 5.8.3.1 | Probe Holder Setup .....  | 58 |
| 5.8.3.2 | Probe Holder Adjustment .....                                       | 60 |
| 5.8.3.3 | Probe Holder Force Adjustment .....                                 | 60 |
| 5.8.3.4 | Slip Joint Probe Holder Left/Right Conversion.....                  | 62 |
| 5.9.    | Probe Holder Frames .....   | 64 |
| 5.9.1.  | Low Profile Probe Holder Frame - Flat or Circumferential Only ..... | 64 |
| 5.9.2.  | Vertical Probe Holder Frame - Flat or Circumferential Only .....    | 68 |
| 5.9.3.  | Pivoting Probe Holder Frame .....                                   | 72 |
| 5.9.3.1 | Mounting a Pivoting Probe Holder Frame .....                        | 73 |
| 5.9.4.  | Pivoting Probe Holder Frame Setup - Longitudinal Scanning .....     | 74 |
| 5.9.4.1 | Longitudinal Scanning .....   | 74 |
| 5.9.4.2 | Circumferential Scanning .....                                      | 75 |
| 5.9.4.3 | Pivoting Probe Holder Frame - Flange Scanning .....                 | 76 |
| 5.9.5.  | Battery Powered Optical Guide Pivot Mount .....                     | 79 |
| 5.10.   | HT Cable and Hose Management .....                                  | 80 |
| 5.10.1. | Mounting the HT Cable Management .....                              | 80 |
| 5.10.2. | Cable Management Setup .....  | 81 |
| 5.10.3. | Clamp Setup .....   | 82 |
| 5.10.4. | Hose Connection and Routing .....                                   | 82 |
| 5.10.5. | Disconnecting Hoses .....   | 83 |
| 5.11.   | Accessories .....   | 84 |
| 5.11.1. | Battery Powered Optical Guide .....                                 | 84 |

# 6

## Operation ..... 85

|         |  |    |
|---------|--|----|
| 6.1.    | System Startup .....                             | 85 |
| 6.2.    | Placement of Crawler on Inspection Surface ..... | 87 |
| 6.3.    | Removal of Crawler from Inspection Surface ..... | 90 |
| 6.4.    | Operation .....                                  | 92 |
| 6.4.1.  | Handheld Controller Layout .....                 | 92 |
| 6.4.1.1 | Touchscreen .....                                | 93 |
| 6.4.1.2 | D-pad .....                                      | 93 |
| 6.4.1.3 | Joysticks .....                                  | 93 |
| 6.4.2.  | Mode Select Screen .....                         | 94 |
| 6.4.3.  | Jog Mode .....                                   | 94 |
| 6.4.4.  | Latched Jog Mode .....                           | 96 |

|         |  |     |
|---------|--|-----|
| 6.4.5.  | 1 Axis Scan Mode .....                 | 97  |
| 6.4.5.1 | 1 Axis Scan Screen .....               | 98  |
| 6.4.6.  | Cooler Mode.....                       | 100 |
| 6.4.7.  | Cooler Warnings .....                  | 102 |
| 6.4.8.  | System Utilities Screen .....          | 103 |
| 6.4.8.1 | User Settings Screen .....             | 103 |
| 6.4.8.2 | Diagnostics Screens .....              | 104 |
| 6.4.8.3 | Touch Calibration Screen .....         | 105 |
| 6.4.8.4 | Joystick Calibration Screen .....      | 105 |
| 6.4.8.5 | Draw .....                             | 106 |
| 6.4.9.  | High Internal Temperature Screen ..... | 107 |

|          |   |            |
|----------|---|------------|
| <b>7</b> | <b>Maintenance.....</b>                     | <b>108</b> |
| 7.1.     | Safety Precautions Before Maintenance ..... | 108        |
| 7.2.     | Cleaning .....                              | 108        |
| 7.3.     | Maintenance Schedule .....                  | 109        |

|          |                                       |            |
|----------|---------------------------------------|------------|
| <b>8</b> | <b>Troubleshooting .....</b>          | <b>110</b> |
| 8.1.     | Startup Issues .....                  | 110        |
| 8.1.1.   | Joystick Off Center .....             | 110        |
| 8.1.2.   | Checking Network .....                | 111        |
| 8.2.     | Startup Override .....                | 111        |
| 8.2.1.   | Scan Devices .....                    | 112        |
| 8.2.2.   | Reset Parameters .....                | 113        |
| 8.2.3.   | System Parameters .....               | 113        |
| 8.2.4.   | Device Address.....                   | 113        |
| 8.3.     | Additional Issues .....               | 114        |
| 8.4.     | Retrieval of a Stranded Crawler ..... | 115        |
| 8.5.     | Technical Support .....               | 115        |

|          |                                 |            |
|----------|---------------------------------|------------|
| <b>9</b> | <b>Service and Repair .....</b> | <b>116</b> |
|----------|---------------------------------|------------|

|           |                                    |            |
|-----------|------------------------------------|------------|
| <b>10</b> | <b>Spare Parts .....</b>           | <b>117</b> |
| 10.1.     | SKOOT HT Crawler .....             | 117        |
| 10.2.     | SKOOT HT Kit Components .....      | 118        |
| 10.2.1.   | Encoder Connector Type .....       | 120        |
| 10.2.2.   | Power Cord Type .....              | 120        |
| 10.2.3.   | HT Cable Management Sleeving ..... | 121        |
| 10.3.     | Hose Spare Parts .....             | 121        |
| 10.4.     | Probe Holder Frame .....           | 122        |

|          |   |     |
|----------|---|-----|
| 10.5.    | Low Profile Probe Holder Frame .....      | 123 |
| 10.6.    | Pivoting Probe Holder Frame .....         | 124 |
| 10.7.    | Slip Joint Probe Holder Parts .....       | 125 |
| 10.8.    | Vertical Probe Holder Parts .....         | 126 |
| 10.9.    | Heavy Duty Vertical Probe Holder .....    | 127 |
| 10.10.   | Corrosion Thickness Probe Holder HT ..... | 128 |
| 10.11.   | Probe Holder Components .....             | 129 |
| 10.11.1. | Arm Style .....                           | 129 |
| 10.11.2. | Yoke Style .....                          | 129 |
| 10.11.3. | Swing Arm Style .....                     | 129 |
| 10.11.4. | Heavy Duty Yoke Style .....               | 129 |
| 10.11.5. | Pivot Button Style .....                  | 129 |
| 10.12.   | Variable Components .....                 | 130 |
| 10.12.1. | Frame Bar .....                           | 130 |
| 10.13.   | Cases .....                               | 131 |

|           |                       |            |
|-----------|-----------------------|------------|
| <b>11</b> | <b>Disposal .....</b> | <b>132</b> |
|-----------|-----------------------|------------|

|           |                               |            |
|-----------|-------------------------------|------------|
| <b>12</b> | <b>Limited Warranty .....</b> | <b>133</b> |
|-----------|-------------------------------|------------|

# IDENTIFICATION

## 1.1. Product Brand

The SKOOT • HT is a remotely operated vehicle with magnetic wheels suitable for driving on ferrous material. Its primary purpose is to move inspection equipment over areas of structures, such as tanks or pipes, made from ferrous materials in industrial environments.

## 1.2. Manufacturer

Distributor:

Manufacturer:

Jireh Industries Ltd.  
53158 Range Road 224  
Ardrossan, Alberta T8E 2K4  
Canada  
Phone: 780.922.4534  
jireh.com

## 1.3. Compliance Declarations

### 1.3.1. ISED Emissions Compliance (Canada)

CAN ICES-003(A) / NMB-003(A)

This Class A digital apparatus complies with Canadian ICES-003.

*Cet appareil numérique de la classe A est conforme à la norme NMB-003 du Canada.*

### 1.3.2. FCC Suppliers Declaration of Conformity (United States)

This device complies with Part 15 of the FCC Rules. Operation is subject to the following two conditions: (1) this device may not cause harmful interference, and (2) this device must accept any interference received, including interference that may cause undesired operation.

This equipment has been tested and found to comply with the limits for a Class A digital device, pursuant to part 15 of the FCC Rules. These limits are designed to provide reasonable protection against harmful interference when the equipment is operated in a commercial environment. This equipment generates, uses, and can radiate radio frequency energy and, if not installed and used in accordance with the instruction manual, may cause harmful interference to radio communications. Operation of this equipment in a residential area is likely to cause harmful interference in which case the user will be required to correct the interference at his own expense.

|                                |   |
|--------------------------------|---|
| <b>RESPONSIBLE PARTY NAME:</b> | Jireh Industries  |
| <b>ADDRESS:</b>                | 2955 S Sam Houston Pkwy E<br>Suite 300<br>Houston, Texas<br>United States 77047 |
| <b>TELEPHONE:</b>              | 832-564-0626  |

### 1.3.3. European Union CE Declarations



Jireh Industries hereby declares that the SKOOT HT product complies with the essential requirements and other relevant provisions of the following European Union directives:

- 2014/30/EU      EMC Directive
- 2014/35/EU      Low Voltage Directive
- 2012/19/EU      Directive on Waste Electrical and Electronic Equipment
- 2011/65/EU      Directive on Restriction of Hazardous Substances (RoHS)

### 1.3.4. UKCA Declarations



Jireh Industries hereby declares that the SKOOT HT product complies with the essential requirements and other relevant provisions of the following UK directives.

| Title   | Edition/Date of Issue |
|---|-----------------------|
| Electromagnetic Compatibility Regulations   | 2016                  |
| Electrical Equipment (Safety) Regulations   | 2016                  |
| Waste Electrical and Electronic Equipment Regulations   | 2013                  |
| Restriction of the Use of Certain Hazardous Substances in Electrical and Electronic Equipment Regulations | 2012                  |

## PRODUCT SPECIFICATIONS

### 2.1. Base SKOOT HT System Specifications

This section outlines the product specifications of the base system. When the base system is used together with compatible components (*Chaper 2.2*) or child products (*Chaper 2.3*), the product specifications of the base system may be superseded. See (*see "Compatible Components" on page 10*) and (*see "Child Products" on page 13*).

#### 2.1.1. Intended Use



#### **WARNING! FALLING OBJECT HAZARD.**

The **SKOOT HT** is intended for a specific use. Read and understand the intended and unintended use limits below. Using the **SKOOT HT** outside of its intended use is dangerous and could result in **SEVERE INJURY** or **DEATH**.

The **SKOOT HT**'s primary purpose is to perform inspections of ferrous assets such as pipes, vessels, or storage tanks by moving an inspection tool over a ferrous surface. It is intended for industrial use only.

### 2.1.1.1 Operating Limits

| Category                    | Parameter  | Specification  |
|-----------------------------|--|--|
| Inspection Surface          | Maximum coating thickness:   |  |
|                             | Up-side-down orientation   | Bare metal only  |
|                             | Vertical orientation   | 0.5 mm (0.020 in)  |
|                             | Horizontal, Right-side-up orientation  | 1 mm (0.040 in)  |
|                             | Condition  | Clean, free of excess rust, scale, debris (i.e. dirt, sand, etc.), ice, frost                        |
|                             | Minimum thickness  | 3 mm (0.120 in)  |
|                             | Minimum ID, internal circumferential driving   | 686 mm (27 in)   |
|                             | Minimum ID, internal longitudinal driving  | Flat (Internal longitudinal driving not recommended)   |
|                             | Minimum OD, external circumferential driving   | 102 mm (4 in)  |
|                             | Minimum OD, external longitudinal driving  | 762 mm (30 in)   |
| Maximum surface temperature | 350°C (662°F)  |  |
| Scanner                     | Maximum umbilical length   | 30 m (100 ft)  |
|                             | Maximum payload (performance may vary with surface condition)  | 9 kg (20 lb) (Umbilical and attachments are considered payload)                                      |
|                             | Attachments  | Restricted to those listed in compatible components or child products                                |
|                             | Orientation while driving at height >2 m (6 ft) on vertical surface  | Umbilical strain relief to point downwards, or at worst, horizontal. It is not to point upwards      |
|                             | Required radial clearance (stick handle and backpack removed, front handle lowered, circumferential driving) | 102 mm (4 in) on outer diameters <200 mm (8 in)<br>112 mm (4.4 in) on outer diameters >200 mm (8 in) |

### 2.1.1.2 Operating Environment

The **SKOOT HT** is for use in dry industrial environments having ambient temperatures shown below. It is **NOT** intended for use in explosive environments.

**NOTE:** *The Cooler has sufficient cooling capacity to continuously cool the **SKOOT HT** with Raster Arm HT operating on a 350°C (662°F) surface, provided the Cooler is kept in an ambient temperature less than 35°C (95°F). Operation with a duty cycle or supplemental cooling may be required for ambient temperatures greater than 35°C (95°F).*

| Category    | Parameter                   | Specification |
|-------------|-----------------------------|---------------|
| Environment | Minimum ambient temperature | -20°C (-4°F)  |
|             | Maximum ambient temperature | 50°C (122°F)  |

### 2.1.1.3 User

The **SKOOT HT** is intended to be used by persons who have read and understand the user manual. The intended user is to be a person without limitations in the physical abilities of the upper and lower limbs, sight, hearing, or anyone with a pacemaker or Implantable Cardioverter Defibrillator (ICD).

For operating at a height greater than 2 m (6 ft), the **SKOOT HT** is intended to be used by two people:

1. a person who is trained in rigging and fall protection and is able to effectively apply the same safety principles to the crawler, and
2. a person who is trained to operate the **SKOOT HT**

## 2.1.2. Unintended Use

The SKOOT HT is **NOT** intended for:

- ▶ use outside of its intended use
- ▶ unattended use
- ▶ lifting / lowering objects or people (i.e. using the **SKOOT HT** as a crane / elevator)
- ▶ driving into / over obstructions, excluding standard weld caps
- ▶ installation on a surface on which welding is actively occurring

In addition to the above points, for operating at a height greater than 2 m (6 ft), the crawler is **NOT** intended for:

- ▶ operation without a properly cordoned off no entry fall zone and/or proper tether system
- ▶ operating up-side-down
- ▶ operating while oriented such that the umbilical strain relief points upward (*front for the SKOOT HT is lower than the umbilical connection*).

### 2.1.3. Dimensions and Weight

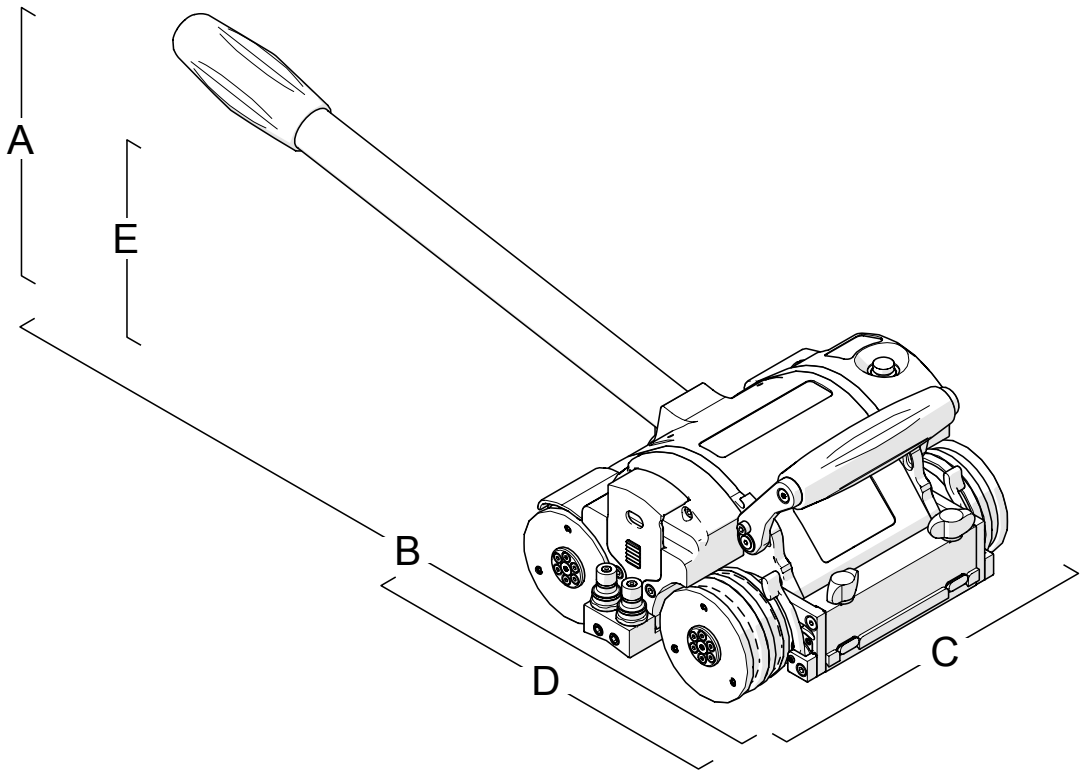

Fig. 1 - Dimensions

|   |         |         |
|---|---------|---------|
| A:                                      | 16 cm   | 6.3 in  |
| B:                                      | 55.5 cm | 21.8 in |
| C:                                      | 22.9 cm | 9 in    |
| D: <i>(without manipulation handle)</i> | 23.3 cm | 9.1 in  |
| E: <i>(without manipulation handle)</i> | 11.2 cm | 4.4 in  |
| Crawler weight:                         | 7.7 kg  | 16.9 lb |

## 2.1.4. Power Requirements



**WARNING!** A reliable power source must be used to power the crawler. Connections must be secured to prevent accidental disconnection. Power failure may cause the crawler to freewheel down when operating in a vertical orientation. Portable generator usage is not recommended unless accompanied by the use of an uninterruptible system controller.



**WARNING!** Proper grounding of the system controller is important for safe operation. When a generator is used to supply power to the system (*not recommended*), the generator must be properly grounded (*refer to generator manual*).



**CAUTION! DO NOT DISCONNECT UNDER LOAD.** Shut off power before connection or disconnecting. Permanent damage to electronics could occur.



**CAUTION!** Power must be supplied from an approved Jireh power source.

|                |          |
|----------------|----------|
| Input Voltage: | 25-45VDC |
| Input Power:   | 320W     |

## 2.1.5. Environmental Sealing

Dust-tight, watertight (*not submersible*).

### 2.1.6. Performance Specifications

| Category | Parameter                       | Specification                    |
|----------|---------------------------------|----------------------------------|
| Crawler  | Maximum speed                   | 14.2 cm/sec (5.6 in/sec)         |
|          | Encoder resolution, drive motor | 1354 counts/mm (34394 counts/in) |

### 2.1.7. Encoder Interface Specifications

Output type: 4 channel quadrature 5VDC RS422 compatible.

Power: Power must be supplied to the interface.  
5VDC +/-10% power limited to < 15w.

|    |            |
|----|------------|
| 1  | Enc B      |
| 2  | Enc B'     |
| 3  | Enc A      |
| 4  | Enc A'     |
| 5  | Aux Enc A' |
| 6  | Aux Enc A  |
| 7  | Aux Enc B' |
| 8  | Aux Enc B  |
| 9  | Enc +5V    |
| 10 | Enc Com    |
| H  | Shield     |

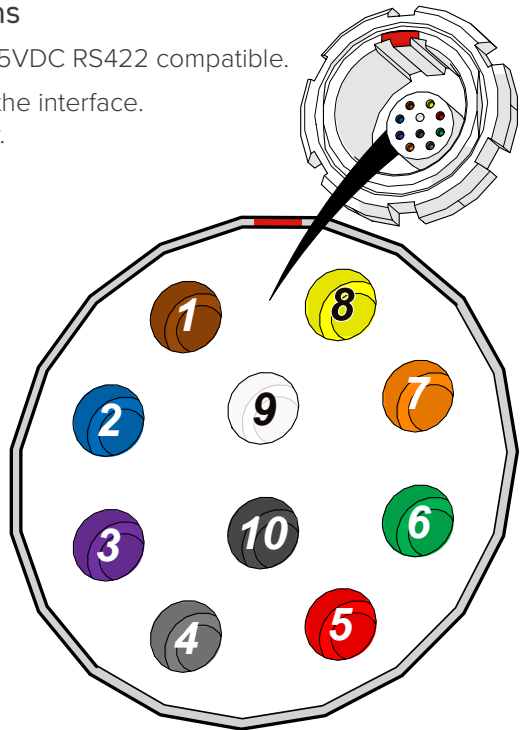

Fig. 2 - JIREH Industries pin out configuration

## 2.2. Compatible Components

The components listed in this section integrate with the base system to perform certain tasks. Their use may modify the product specifications (*i.e. intended use, power requirements, etc.*) from those of the base system. The specifications listed here supersede those of the base system. If no specifications are listed here, the specifications of the base system remain effective

### 2.2.1. Low Profile Probe Holder Frame CXG004-

#### 2.2.1.1 Intended Use

The Low Profile Probe Holder Frame is intended to be mounted in the SKOOT HT's swivel mount to provide mounting of multiple probe holders. Its use limits the SKOOT HT's operation to inspection surfaces that are either flat or driven on in the circumferential direction.

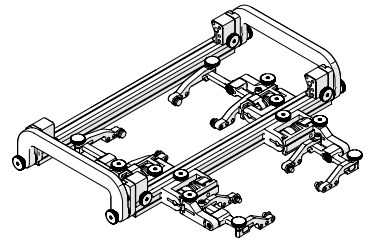

Fig. 3 - Low profile probe holder frame

#### 2.2.1.2 Operating Limits

| Category                        | Parameter                        | Specification   |
|---------------------------------|----------------------------------|-----------------|
| Inspection Surface              | Minimum OD, longitudinal driving | Not recommended |
| Maximum number of probe holders | Slip Joint Probe Holders         | 4               |

### 2.2.2. Vertical Probe Holder Frame CXG007-

#### 2.2.2.1 Intended Use

The Vertical Probe Holder Frame is intended to be mounted in the SKOOT HT's swivel mount to provide mounting of multiple probe holders. Its use limits the SKOOT HT's operation to inspection surfaces that are either flat or driven on in the circumferential direction.

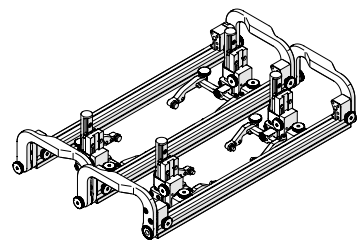

Fig. 4 - Vertical probe holder frame

### 2.2.2.2 Operating Limits

| Category                        | Parameter                           | Specification   |
|---------------------------------|-------------------------------------|-----------------|
| Inspection Surface              | Minimum OD,<br>longitudinal driving | Not recommended |
| Maximum number of probe holders | Vertical Probe Holders              | 6               |

### 2.2.3. Pivoting Probe Holder Frame CXG013-

#### 2.2.3.1 Intended Use

The Pivoting Probe Holder Frame is intended to be mounted in the SKOOT HT's swivel mount to provide mounting of multiple probe holders. Its use limits the SKOOT HT's operation to the operating limits shown below.

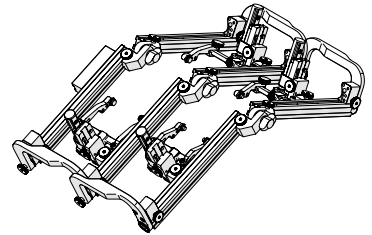

Fig. 5 - Pivoting probe holder frame

#### 2.2.3.2 Operating Limits

| Category                        | Parameter              | Specification |
|---------------------------------|------------------------|---------------|
| Maximum number of probe holders | Vertical Probe Holders | 6             |

### 2.2.4. Frame Bar BG0038-

#### 2.2.4.1 Intended Use

The Frame Bar is intended to be mounted in the SKOOT HT's swivel mount to provide mounting of multiple probe holders. Its use limits the SKOOT HT's operation to inspection surfaces that are either flat or driven on in the circumferential direction.

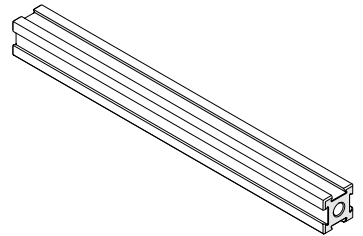

Fig. 6 - Frame bar

#### 2.2.4.2 Operating Limits

| Category           | Parameter                           | Specification   |
|--------------------|-------------------------------------|-----------------|
| Inspection Surface | Minimum OD,<br>longitudinal driving | Not recommended |

|                                 |                                   |   |
|---------------------------------|-----------------------------------|---|
| Maximum number of probe holders | Slip joint probe holders          | 2 |
|                                 | Vertical probe holders            | 2 |
|                                 | Heavy duty vertical probe holders | 2 |

## 2.2.5. Battery Powered Optical Guide CXS080

### 2.2.5.1 Intended Use

The Battery Powered Optical Guide is intended to provide a point of reference useful for guiding the **SKOOT HT** along a given path (*i.e. a weld cap*). It is intended to be mounted in the dovetail groove of any probe holder frame or frame bar.

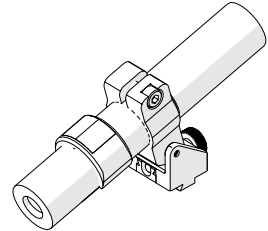

Fig. 7 - Battery powered optical guide

### 2.2.5.2 Operating Environment

| Category           | Parameter                   | Specification   |
|--------------------|-----------------------------|---|
| Scanner            | Required radial clearance   | Dependent on mounted orientation of Battery Powered Optical Guide |
| Inspection surface | Maximum surface temperature | 50°C (122°F)  |

### 2.2.5.3 Power Requirements

Power requirements: 1 AA Battery

### 2.2.5.4 Environmental Sealing

IP64

## 2.3. Child Products

The products listed in this section integrate with the base system to perform certain tasks. Their use may modify the product specifications (*i.e. intended use, power requirements, etc.*) from those of the base system. These products have a user manual of their own, and shall be referred to for their product specifications as well as how their use modifies the product specifications of the base system.

### 2.3.1. Motorized Couplant Pump CMA015

The Motorized Couplant Pump is a powered pumping unit used to supply couplant fluid to scanning equipment.

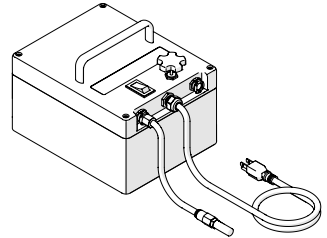

Fig. 8 - Motorized couplant pump

### 2.3.2. Motorized Raster Arm HT EDG001-

The Motorized Raster Arm HT is a high temperature component which can carry different types probes for various corrosion scans. The Motorized Raster Arm HT is intended to be mounted in the SKOOT HT's swivel mount.

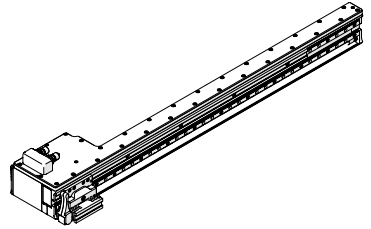

Fig. 9 - Motorized raster arm HT

### 2.3.3. Battery Kit DVG001-

The battery provides portable power to the crawler.

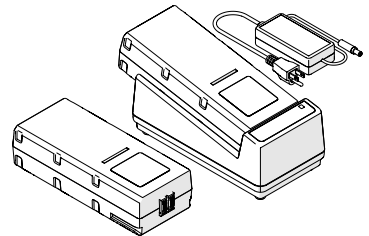

Fig. 10 - Battery

## DEFINITIONS

### 3.1. Definitions of Symbols



Instructions to 'look here' or to 'see this part'.

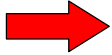

Denotes movement. Instructing user to carry out action in a specified direction.

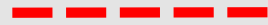

Indicates alignment axis.



Alerts user that view has changed to a reverse angle.

### 3.2. Safety Symbols

The following safety symbols might appear on the product and in this document. Read and understand their meaning below:



General warning symbol

This symbol is used to alert the user to potential hazards. All safety messages that follow this symbol shall be obeyed to avoid possible harm or material damage.



Shock hazard caution symbol

This symbol is used to alert the user to potential electric shock hazards. All safety messages that follow this symbol shall be obeyed to avoid possible harm.



Laser warning symbol

This symbol is used to alert the user to potential laser hazards. All safety messages that follow this symbol shall be obeyed to avoid possible harm or material damage.

### 3.3. Safety Signal Words

The following safety signal words might appear in this document. Read and understand their meaning below:

#### **DANGER!**

The DANGER signal word indicates an imminently hazardous situation. It calls attention to a procedure, practice, or the like that if not correctly performed or adhered to will result in death or serious personal injury. Do not proceed beyond a DANGER signal word until the indicated conditions are fully understood and met.

#### **WARNING!**

The WARNING signal word indicates a potentially hazardous situation. It calls attention to a procedure, practice, or the like that if not correctly performed or adhered to could result in death or serious personal injury. Do not proceed beyond a WARNING signal word until the indicated conditions are fully understood and met.

#### **CAUTION!**

The CAUTION signal word indicates a potentially hazardous situation. It calls attention to a procedure, practice, or the like that if not correctly performed or adhered to may result in minor or moderate personal injury, material damage, particularly to the product, destruction of part or all of the product, or loss of data. Do not proceed beyond a CAUTION signal word until the indicated conditions are fully understood and met.

# SYSTEM COMPONENTS

## 4.1. Base System Components

### 4.1.1. SKOOT • HT (Crawler) DPA003



**WARNING! MAGNETIC MATERIAL.** The wheels of the crawler produce an extremely strong magnetic field which may cause failure or permanent damage to items such as watches, memory devices, CRT monitors, medical devices or other electronics. People with pacemakers or ICD's must stay at least 25 cm (10 in) away.

The crawler includes the motor encoder, umbilical connections and accessory mounting point.

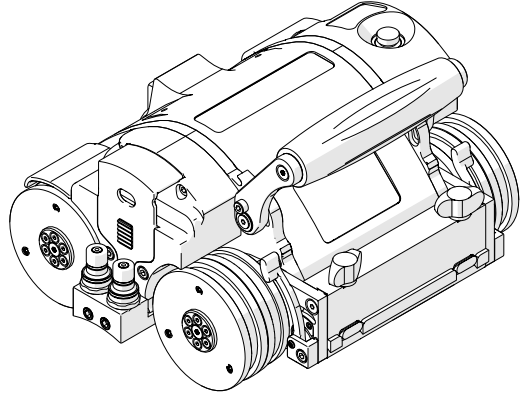

Fig. 11 - SKOOT • HT (crawler)

#### 4.1.1.1 Off Button

The red button located on the top left of the crawler provides an off button to the entire system. When pressed, all power to the SKOOT HT system will disengage.

**NOTE:** Terminating system power may cause the crawler to freewheel down when operating in a vertical orientation.

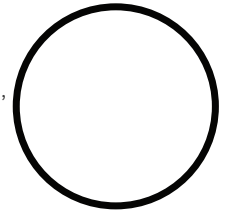

Fig. 12 - Off button

## 4.1.2. System Controller EPA002-



**CAUTION! DO NOT DISCONNECT UNDER LOAD.** Shut off power before connection or disconnecting. Permanent damage to electronics could occur.



**WARNING!** There are no user serviceable components inside the system controller. Dangerous voltages can be present inside the case. Do **NOT** open. Return to manufacturer for repair.

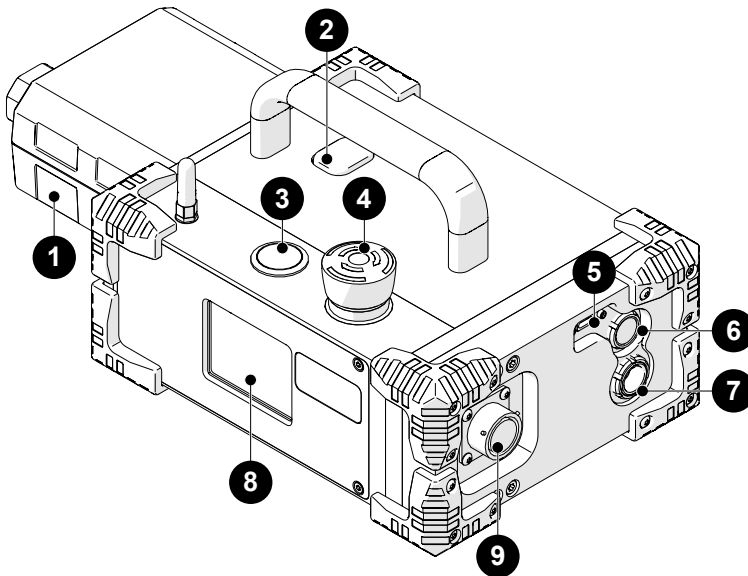

Fig. 13 - System controller

The system controller accepts 25-45VDC power from the AC/DC power supply or battery. A start/stop circuit and physical **ON** and **OFF** push-buttons are integrated into the system controller.

1

AC/DC power supply

Connect plug from a properly grounded source.  
Use IEC320 cord approved for AC/DC power supply.

|   |                      |  |
|---|----------------------|--|
| 2 | Release button       | Unlatch the AC/DC power supply or battery from the system controller.  |
| 3 | Power button         | Activate system power by pressing <i>(and releasing)</i> the silver button.  |
| 4 | Off button           | The red off button latches down when pressed, this off button shuts down the system. Twist the off button clockwise to return to the released position. This must be done before power can be activated. |
| 5 | Scanlink™ connector  | Connection for Scanlink devices.   |
| 6 | CTRL socket          | Connection for the auxiliary cable.  |
| 7 | ENC socket           | Connection for the encoder cable.  |
| 8 | Status LCD           | System controller status display.  |
| 9 | Umbilical connection | Connection for the umbilical.  |

In the event of a break in the stop circuit (*the stop circuit runs through the system controller cable, umbilical and the crawler's off button*), power will shut off.

#### 4.1.2.1 AC/DC Power Supply



**WARNING! ELECTRICAL CORDS CAN BE HAZARDOUS.** Misuse can result in **FIRE** or **DEATH** by **ELECTRICAL SHOCK**. Inspect thoroughly before each use. Do **NOT** use if damaged. Do **NOT** use when wet. Keep away from water. Do **NOT** drive, drag or place objects over cord.

The **1** AC/DC power supply (*Fig. 13*) is used to connect the system controller to a suitable 100-240VAC, 50/60Hz grounded power source capable of supplying a minimum of 5 amps.

The safety of the system controller relies on the provision of a proper ground connection.

In environments with moisture present, a GFCI (*Ground Fault Circuit Interrupter*) must be used to ensure operator safety.

**NOTE:** Some generators or DC-AC inverters may introduce significant levels of noise to the system. This may degrade overall system performance or reduce the system life expectancy. Use of generators or DC-AC inverters is not recommended and are used at the operator's risk.

### 4.1.3. SKOOT HT Umbilical UMA043-

The umbilical is the backbone of the system, connecting the crawler to the system controller. While designed for high temperature operation, the umbilical must be protected in the high temperature cable management at all times.

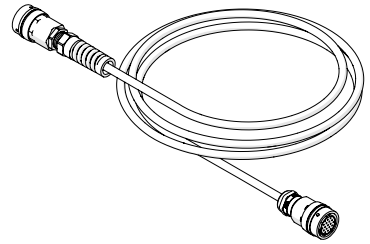

Fig. 14 - SKOOT HT umbilical

### 4.1.4. Handheld Controller DMA006



**WARNING! MAGNETIC MATERIAL.** The handheld controller contains magnetic material. Those with pacemakers or ICD's must stay at least 10 cm (4 in) away.



**CAUTION! DO NOT DISCONNECT UNDER LOAD.** Shut off power before connection or disconnecting. Permanent damage to electronics could occur.



The handheld controller is used to manipulate a scanner installed on an inspection surface. User settings and scan information are edited using the handheld controller.

The handheld controller utilizes a resistive touch screen, care should be taken to not use sharp or gritty objects on the screen as the touch membrane can scratch. If the screen is damaged, all programmed functions can still be accessed using the D-pad.

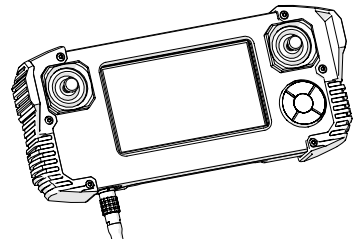

Fig. 15 - Handheld controller

**NOTE:** Do **NOT** connect the handheld controller while the system is activated.

#### 4.1.5. Manipulation Handle DNS006

The manipulation handle is used to assist with the placement of the crawler onto the scan surface. As well, the manipulation handle can be used to make small adjustments to the direction of the crawler's travel.

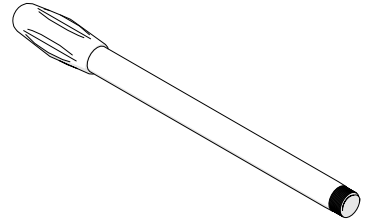

Fig. 16 - Manipulation handle

#### 4.1.6. Auxiliary Cables UMA017-

The auxiliary cables connect the handheld controller, cooler and system controller. 36VDC and network signals are used in the cable.

Both auxiliary cable connector ends are identical and interchangeable.

Multiple cables with different lengths are included.

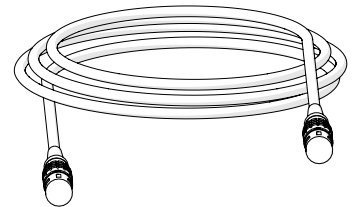

Fig. 17 - Auxiliary cable

#### 4.1.7. J300 Encoder Cable UMA025-

The encoder cable connects the SKOOT HT system to the user's instrument. This cable allows transmission of two-axis position signals from the SKOOT HT to the instrument. The encoder cable also provides 5VDC from the user's instrument to the encoder isolation circuitry.

Various encoder styles are available for various instruments.

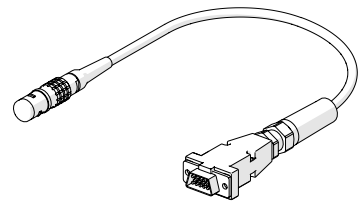

Fig. 18 - Encoder cable

#### 4.1.8. Irrigation Kit CMG009-

The irrigation kit provides a variety of hoses, fittings, connectors and splitters commonly used during non-destructive inspection.

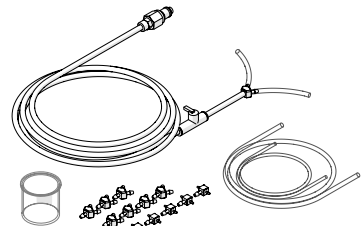

Fig. 19 - Irrigation kit

#### 4.1.9. High Temperature Cable Management, Threaded Mount CXS113-

The high temperature cable management provides a means of protecting and organizing cables, tubes and hoses.

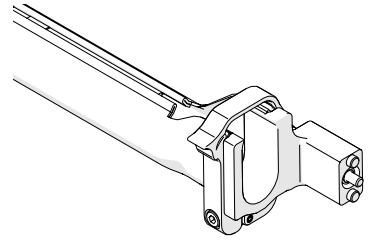

Fig. 20 - HT cable management

#### 4.1.10. Cooler DPA002

The Cooler provides a flow of cooled coolant for use in actively cooling NDT equipment such as manual crawlers, motorized crawlers, probes, etc. that are equipped with cooling passages. *(see "Cooler" user manual for additional details and instructions)*

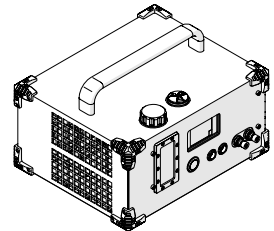

Fig. 21 - Cooler

#### 4.1.11. Hoses DPA004-

Blue and red hoses are included with the Cooler system. The hoses are affixed with quick connects that do not drip or leak when connecting or disconnecting.

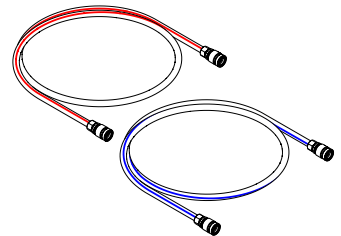

Fig. 22 - Hoses

#### 4.1.12. Tools

Several tools are included for various scanner and accessory adjustment. *(see "Tools" on page 27 for additional details)*

#### 4.1.13. Cases

Depending on the configuration selected at the time of purchase. This will determine the types and amount of cases included with the system.

## 4.2. Compatible Components

### 4.2.1. Low Profile Probe Holder Frame CXG004-

The low profile probe holder frame carries up to four probes during limited access, circumferential weld inspection. Removal of the SKOOT HT handles and the use of the low profile probe holder frame allows inspection when radial clearance is limited.

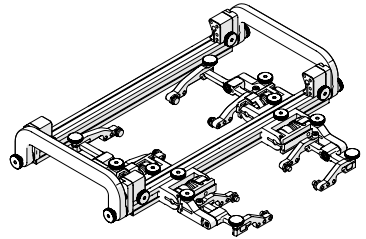

Fig. 23 - Low profile probe holder frame

### 4.2.2. Vertical Probe Holder Frame CXG007-

The vertical probe holder frame carries up to six probes during circumferential weld inspection. Available in a myriad of configurations and lengths, the vertical probe holder frame attaches to the front of the SKOOT HT crawler.

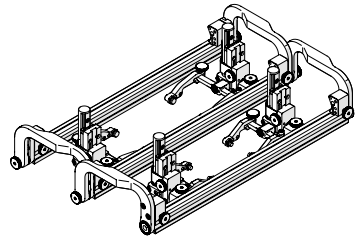

Fig. 24 - Vertical probe holder frame

### 4.2.3. Pivoting Probe Holder Frame CXG013-

The pivoting probe holder frame carries up to six probes during longitudinal weld inspection. Available in a myriad of configurations and lengths, the pivoting probe holder frame may also be used for circumferential weld inspection.

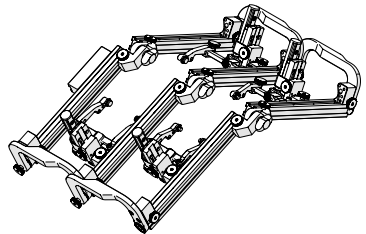

Fig. 25 - Pivoting probe holder frame

### 4.2.4. Frame Bar BG0038-

Frame bars use dovetail grooves into which probe holders and accessories may be attached. Available in various lengths.

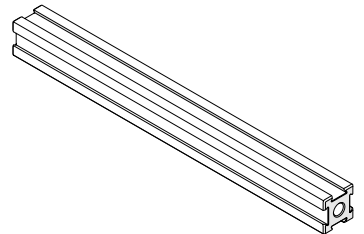

Fig. 26 - Frame bar

#### 4.2.5. Slip Joint Probe Holder PHA012-

The slip joint probe holder is generally used during limited access inspection. The low profile design requires minimal radial clearance. The slip joint probe holder is designed to carry many different types of probes and wedges, it is available with various types of yokes, arms and pivot buttons.

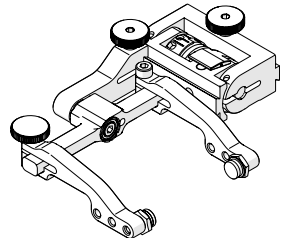

Fig. 27 - Slip joint probe holder

#### 4.2.6. Vertical Probe Holder PHA015-

The vertical probe holder is designed to carry many different types of probes and wedges. Available with various types of yokes, arms and pivot buttons. The vertical probe holder features several different adjustment options for each unique probe/wedge setup.

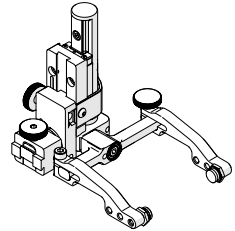

Fig. 28 - Vertical probe holder

#### 4.2.7. Heavy Duty Vertical Probe Holder PHS043-

The heavy duty vertical probe holder is designed to carry larger probes. Available with various arm, yoke and pivot buttons, the heavy duty vertical probe holder exerts more down force on a large footprint probe/wedge.

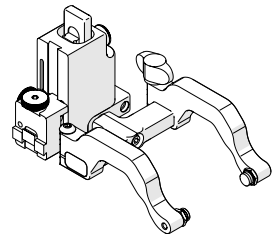

Fig. 29 - Heavy duty vertical probe holder

#### 4.2.8. Corrosion Thickness Probe Holder HT PHS078- / PHS082-

The corrosion thickness probe holder HT carries various probes for the purpose of corrosion inspection and is available with a flat wear plate.

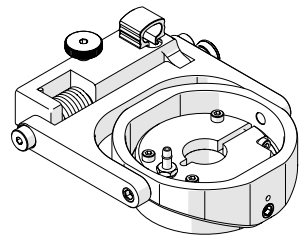

Fig. 30 - Corrosion thickness probe holder HT

#### 4.2.9. SKOOT HT Extension Kit DPG005-

The SKOOT HT Extension Kit allows users to conveniently extend the length of umbilical, coolant lines, and protective sleeving for enhanced customization and flexibility (Fig. 31).

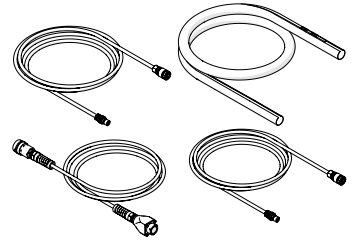

Fig. 31 - SKOOT HT extension kit

#### 4.2.10. Battery Powered Optical Guide CXS080

The battery powered optical guide (Fig. 32) provides a red colour point of reference useful for guiding scanners along a given path (i.e. a weld).

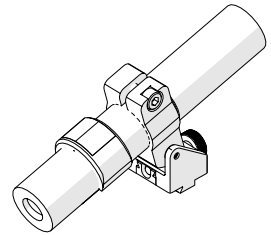

Fig. 32 - Battery powered optical guide

#### 4.2.11. Encoder Adapter UMA010-

The encoder adapter changes the scanner's built in encoder connector style (Fig. 33).

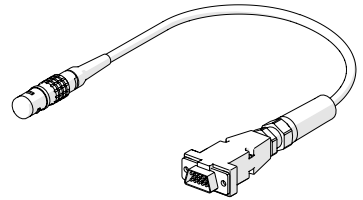

Fig. 33 - Encoder adapter

#### 4.2.12. Battery DVA001

The battery is compatible with the system controller and will power the system for hours at a time (Fig. 34).

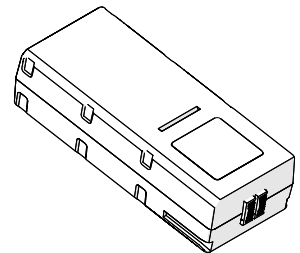

Fig. 34 - Battery

#### 4.2.13. Charger and Power Adapter DVG002-

The charger and power adapter are used to charge the batteries (Fig. 35).

#### 4.2.14. Tools

Several tools are included for various scanner and accessory adjustments (see "Tools" on page 27 for additional details).

#### 4.2.15. Cases

Depending on the configuration selected at the time of purchase. This will determine the types and amount of cases included with the system.

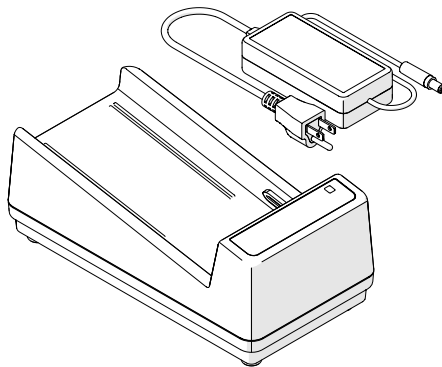

Fig. 35 - Charger and Power Adapter

## 4.3. Child Products

### 4.3.1. Motorized Couplant Pump CMA015

The motorized couplant pump is a powered pumping unit used for supplying couplant fluid to the scanning surface.

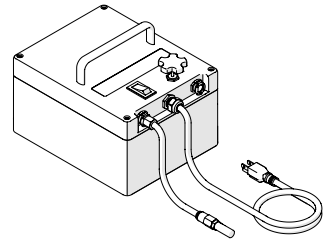

Fig. 36 - Motorized couplant pump

### 4.3.2. Motorized Raster Arm HT EDG001-

The motorized raster arm is available in various lengths and offers programmable speed and travel settings.

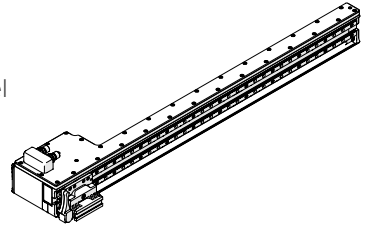

Fig. 37 - Motorized raster arm

### 4.3.3. Battery Kit DVG001-

The rechargeable battery provides portable power to the crawler and components (*i.e. motorized raster arm*).

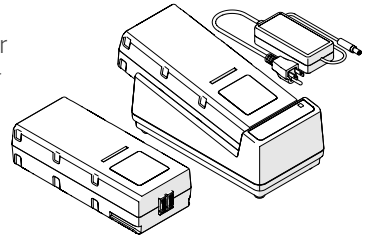

Fig. 38 - Battery kit

## 4.4. Tools

### 4.4.1. Included Tools

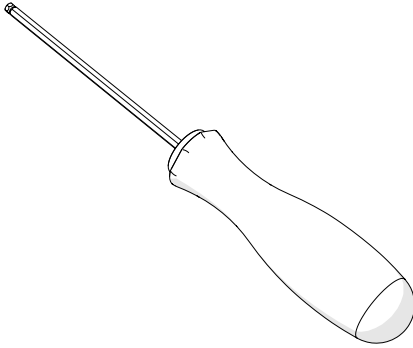

Fig. 39 - 3 mm hex driver

The included 3 mm hex driver (*Fig. 39*) is suitable for typical **SKOOT HT** and probe holder adjustments.

A 3/8 in wrench (*Fig. 40*) is provided to remove and install probe holder buttons.

The included 3 mm flat driver (*Fig. 41*) is useful for releasing the flaps of the Raster Arm HT's cable tray.

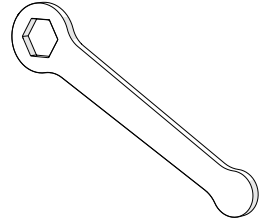

Fig. 40 - 3/8 in wrench

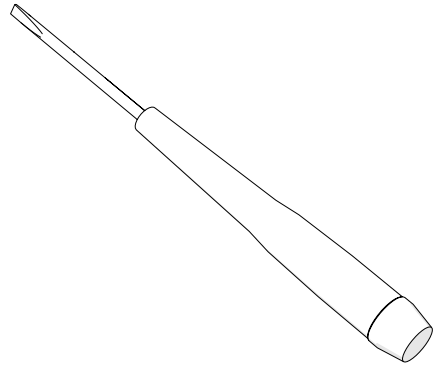

Fig. 41 - 3 mm flat driver

### 4.4.2. Optional Tools

Some specialized adjustments require tools that are not included with this kit.

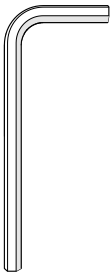

Fig. 42 - 1.5 mm  
hex wrench

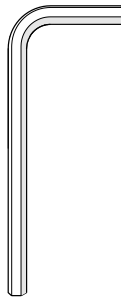

Fig. 43 - 2 mm  
hex wrench

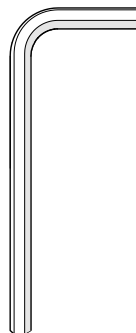

Fig. 44 - 3 mm  
hex wrench

## PREPARATION FOR USE

### 5.1. Transportation



**CAUTION!** PINCH / CRUSH HAZARD. BE CAREFUL when passing the SKOOT HT crawler through narrow ferrous (*magnetic*) openings, such as man-holes. The magnetic drive wheels can cause bodily harm if allowed to slam onto the walls of the opening.

### 5.2. Preparation for Safe Use

#### 5.2.1. No Entry Fall Zone



**WARNING!** FALLING OBJECT HAZARD. The area below a crawler must be kept clear at all times. A clearly marked **NO ENTRY FALL ZONE** must be cordoned off directly below the area of crawler operation.

The area below a crawler must be kept clear at all times. A clearly marked **NO ENTRY FALL ZONE** must be cordoned off directly below the area of crawler operation, according to the dimensions shown in (Fig. 45).

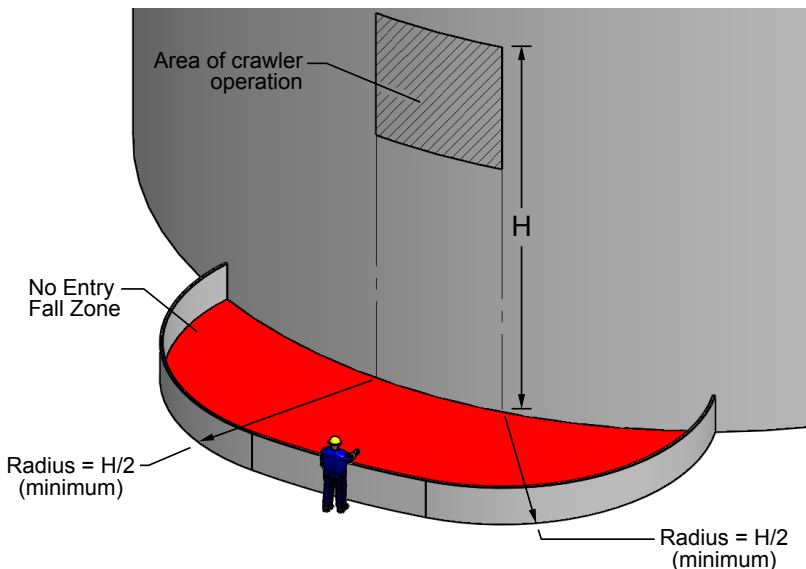

Fig. 45 - No entry fall zone

Example: If inspecting a tank that is 6 m (20 ft) tall, the No Entry Fall Zone radii must be no smaller than 3 m (10 ft) from the area below the area of crawler operation.

## 5.2.2. Tether Requirements and Attachment



**WARNING!** **FALLING OBJECT HAZARD.** Failure to comply with the warnings, instructions, and specifications in this manual could result in **SEVERE INJURY** or **DEATH**.

**WARNING!** Do **NOT** operate or place crawler on a surface higher than 2 m (6 ft) without a proper tether held taut at all times.

**WARNING!** Hook the tether hook to the provided lifting sling **BEFORE** placing the crawler on the surface to be inspected (*e.g. tank*). **IMPORTANT:** Tether hook must have a safety latch to prevent accidental disconnection.

When used at a height greater than 2 m (6 ft), the **SKOOT HT** crawler **MUST** be tethered with a proper tether system to prevent the crawler from falling. The tether system must:

- ▶ be capable of safely suspending the crawler from above in case the crawler detaches from the inspection surface;
- ▶ have sufficient capacity to catch and hold a 70 kg (150 lb) load;
- ▶ include a mechanism (*i.e. self retracting inertia reel fall arrester*) or person to continuously take up slack in the tether as the crawler moves;
- ▶ include a lifting hook with a safety latch to prevent accidental disconnection.
- ▶ be capable of withstanding contact with the inspection surface which may be up to 350°C (662°F), without melting or degrading

Before placing the crawler on the surface to be inspected (*e.g. tank*), attach the tether to the **SKOOT HT**.



**CAUTION!** The overhead attachment point for the tether must be located as close as possible to a location directly above the crawler to minimize dangerous swinging of the crawler should it detach from the inspection surface.

The handle of the SKOOT HT is to be used as an attachment point for a tether.

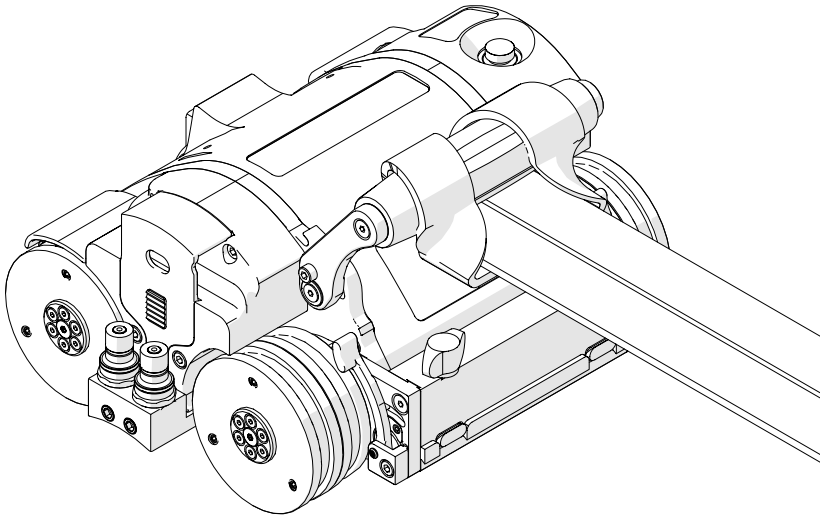

Fig. 46 - Tether attached to SKOOT HT handle

### 5.3. Preparation of Inspection Surface



#### **WARNING! FALLING OBJECT HAZARD.**

The inspection surface must adhere to the conditions outlined in sections "*Intended Use*" on page 3 and "*Operating Environment*" on page 5 of this manual.

- ▶ Remove build-up of scale, and other debris (*i.e. dirt, ice*) from surface on which the crawler is to drive. Excessive build-up will cause the wheels to lose magnetic attraction which may lead to wheel slippage or crawler detachment.
- ▶ Ensure that no obstructions (*other than standard butt welds*) or voids are in the drive path. Obstructions and voids could cause the crawler to fall if driven into or over.
- ▶ Ensure that there are no patches of non-ferrous material in the drive path of the crawler. If the crawler drives over a non-ferrous patch, it will lose magnetic attraction and will cause the crawler to fall.

## 5.4. System Connectivity

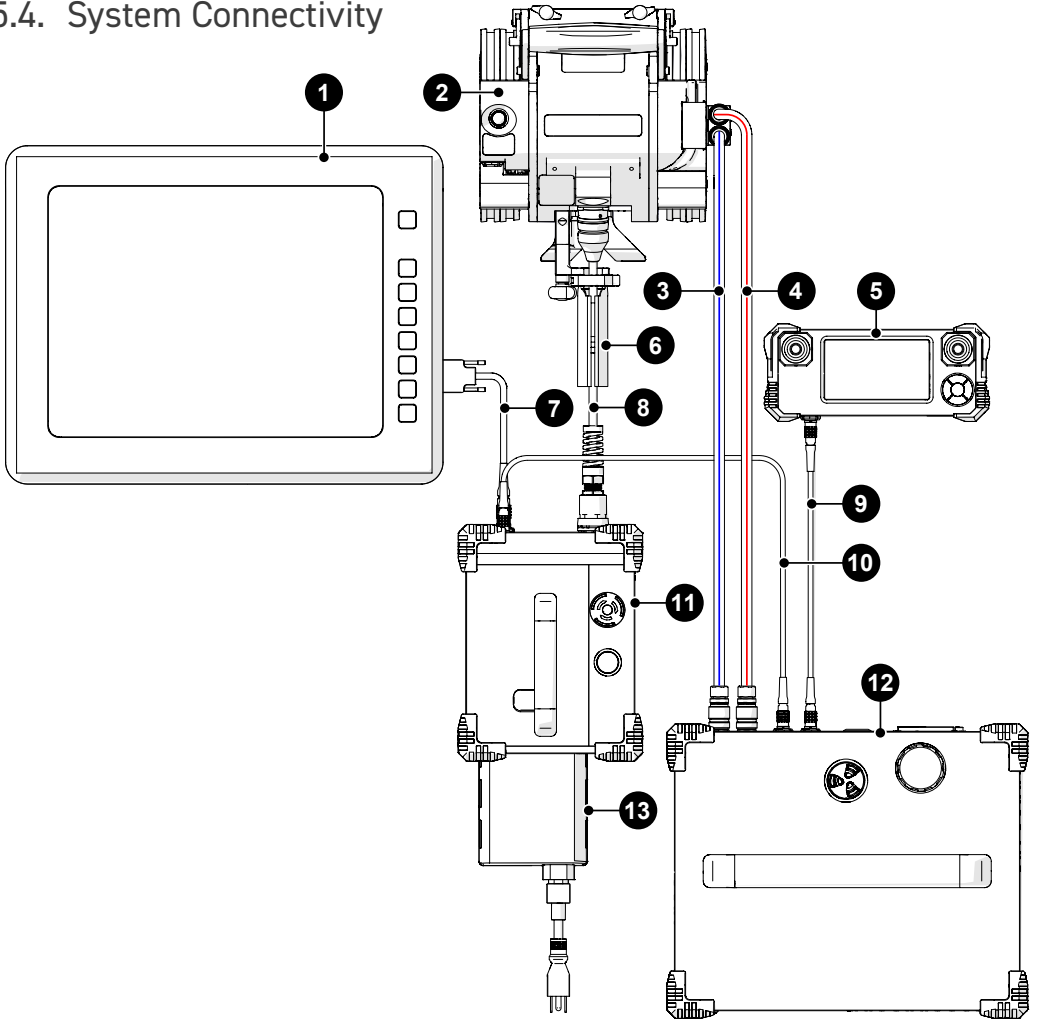

Fig. 47 - Standard configuration

| BOM ID | Description         | BOM ID | Description           |
|--------|---------------------|--------|-----------------------|
| 1      | User instrument     | 8      | Umbilical             |
| 2      | Crawler             | 9      | Auxiliary cable       |
| 3      | Blue hose           | 10     | Short auxiliary cable |
| 4      | Red hose            | 11     | System controller     |
| 5      | Handheld controller | 12     | Cooler                |
| 6      | HT cable management | 13     | AC/DC power supply    |
| 7      | Encoder cable       |        |                       |

To configure the SKOOT HT system, follow these steps:



**CAUTION! DO NOT DISCONNECT UNDER LOAD.** Shut off power before connection or disconnecting. Permanent damage to electronics could occur.

1. Attach the **6** HT cable management to the **2** crawler.
2. Connect the **11** system controller to the **2** crawler using the **8** umbilical.
3. Connect **5** handheld controller to **12** cooler using the **9** auxiliary cable.
4. Connect the **12** cooler to the **11** system controller using the **10** short auxiliary cable.
5. Connect the **3** blue hose to either port on the **2** crawler, Connect the opposite end of the blue hose to the **OUT** port on the **12** cooler.
6. Connect the **4** red hose to either port on the **2** crawler, Connect the opposite end of the red hose to the **OUT** port on the **12** cooler.
7. Route the **8** umbilical, **3** blue hose and the **4** red hose through the **6** HT cable management. (see *Hose Connection and Routing* on page 82 for additional details).
8. Connect the **1** user's instrument to the **11** system controller using the **7** encoder cable.
9. Insert **13** AC/DC power supply into the **11** system controller.
10. (see "Configurations" on page 33) to setup a particular component.

## 5.5. Configurations

### 5.5.1. Crawler with Multiple Probe Holders

#### 5.5.1.1 Low Profile Probe Holder Frame

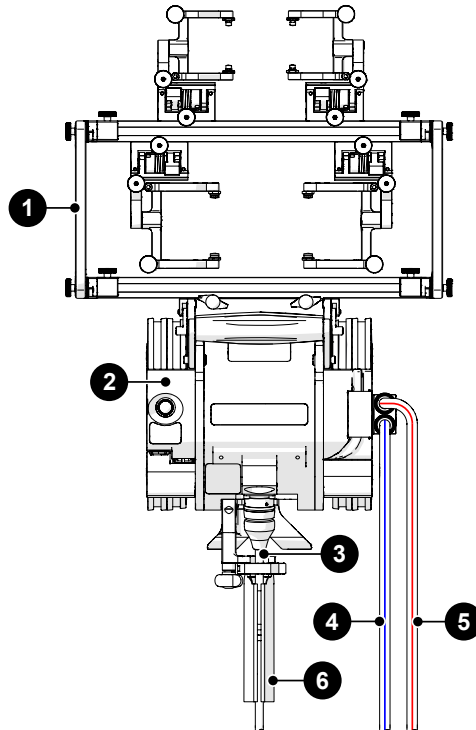

Fig. 48 - Low profile probe holder frame

| BOM ID | Description                    |
|--------|--------------------------------|
| 1      | Low profile probe holder frame |
| 2      | Crawler                        |
| 3      | Umbilical                      |
| 4      | Blue hose                      |
| 5      | Red hose                       |
| 6      | HT Cable management            |

To configure the SKOOT HT system for scanning using a low profile probe holder frame, follow these steps (see "Low Profile Probe Holder Frame - Flat or Circumferential Only" on page 64):



**CAUTION! DO NOT DISCONNECT UNDER LOAD.** Shut off power before connection or disconnecting. Permanent damage to electronics could occur.

1. Attach the **6** HT cable management to the **2** crawler.
2. Connect the **3** umbilical to the **2** crawler.
3. Connect the **4** blue hose to either port on the **2** crawler.
4. Connect the **5** red hose to either port on the **2** crawler.
5. Route the **3** umbilical, **4** blue hose and the **5** red hose through the **6** HT cable management. (see *Hose Connection and Routing* on page 82 for additional details).
6. Attach a configured **1** low profile probe holder frame (see "Low Profile Probe Holder Frame - Flat or Circumferential Only" on page 64) to the **2** crawler (see "Swivel Mount" on page 41).

### 5.5.1.2 Vertical Probe Holder Frame

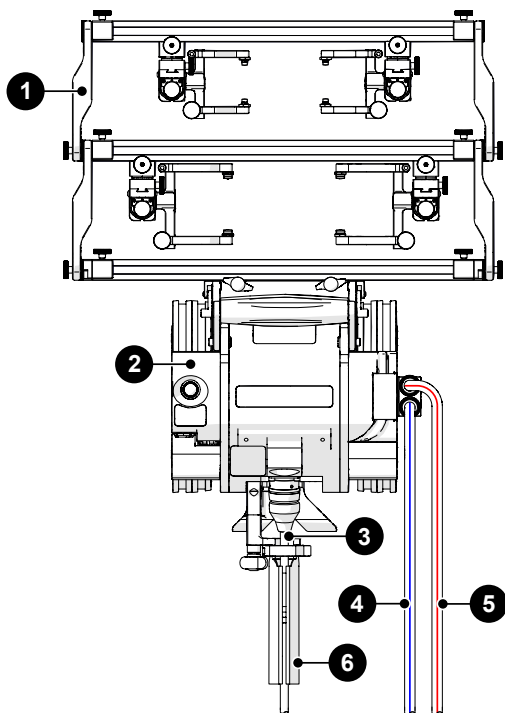

Fig. 49 - Vertical probe holder frame

| BOM ID | Description                 |
|--------|-----------------------------|
| 1      | Vertical probe holder frame |
| 2      | Crawler                     |
| 3      | Umbilical                   |
| 4      | Blue hose                   |
| 5      | Red hose                    |
| 6      | HT Cable management         |

To configure the SKOOT HT system for scanning using a vertical profile probe holder frame, follow these steps (see "Vertical Probe Holder Frame - Flat or Circumferential Only" on page 68):



**CAUTION! DO NOT DISCONNECT UNDER LOAD.** Shut off power before connection or disconnecting. Permanent damage to electronics could occur.

1. Attach the **6** HT cable management to the **2** crawler.
2. Connect the **3** umbilical to the **2** crawler.
3. Connect the **4** blue hose to either port on the **2** crawler.
4. Connect the **5** red hose to either port on the **2** crawler.
5. Route the **3** umbilical, **4** blue hose and the **5** red hose through the **6** HT cable management. (see *Hose Connection and Routing* on page 82 for additional details).
6. Attach a configured **1** vertical probe holder frame (see "Vertical Probe Holder Frame - Flat or Circumferential Only" on page 68) to the **2** crawler (see "Swivel Mount" on page 41).

### 5.5.1.3 Pivoting Probe Holder Frame

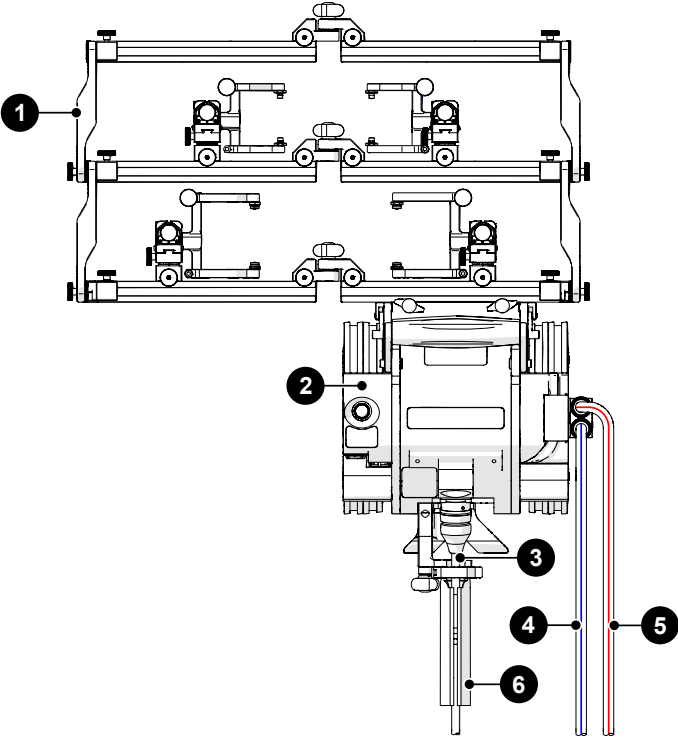

Fig. 50 - Pivoting probe holder frame

| BOM ID | Description                 |
|--------|-----------------------------|
| 1      | Vertical probe holder frame |
| 2      | Crawler                     |
| 3      | Umbilical                   |
| 4      | Blue hose                   |
| 5      | Red hose                    |
| 6      | HT Cable management         |

To configure the SKOOT HT system for scanning using a pivoting probe holder frame, follow these steps (see "Pivoting Probe Holder Frame" on page 72):



**CAUTION! DO NOT DISCONNECT UNDER LOAD.** Shut off power before connection or disconnecting. Permanent damage to electronics could occur.

1. Attach the **6** HT cable management to the **2** crawler.
2. Connect the **3** umbilical to the **2** crawler.
3. Connect the **4** blue hose to either port on the **2** crawler.
4. Connect the **5** red hose to either port on the **2** crawler.
5. Route the **3** umbilical, **4** blue hose and the **5** red hose through the **6** HT cable management. (see *Hose Connection and Routing* on page 82 for additional details).
6. Attach a configured **1** pivoting probe holder frame (see "Pivoting Probe Holder Frame" on page 72) to the **2** crawler (see "Swivel Mount" on page 41).

### 5.5.1.4 Flange

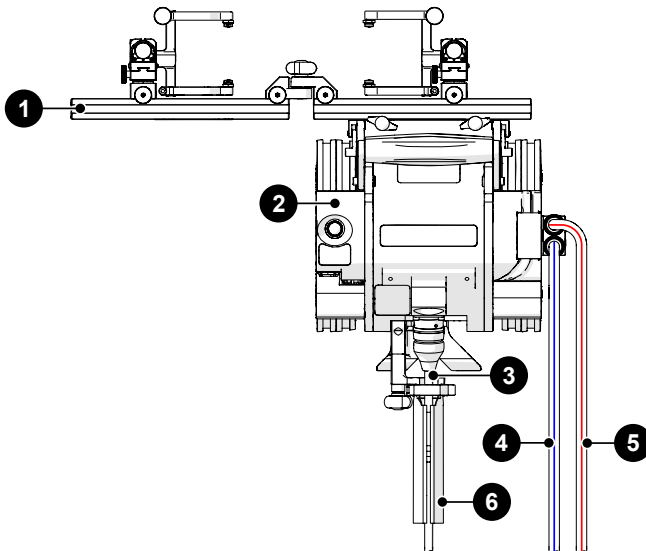

Fig. 51 - Pivoting probe holder frame configured for flange scanning

| BOM ID | Description                 |
|--------|-----------------------------|
| 1      | Vertical probe holder frame |
| 2      | Crawler                     |
| 3      | Umbilical                   |
| 4      | Blue hose                   |
| 5      | Red hose                    |
| 6      | HT Cable management         |

To configure the SKOOT HT system for scanning using a pivoting probe holder frame configured for flange scanning, follow these steps (see "Pivoting Probe Holder Frame - Flange Scanning" on page 76):



**CAUTION! DO NOT DISCONNECT UNDER LOAD.** Shut off power before connection or disconnecting. Permanent damage to electronics could occur.

1. Attach the **6** HT cable management to the **2** crawler.
2. Connect the **3** umbilical to the **2** crawler.
3. Connect the **4** blue hose to either port on the **2** crawler.
4. Connect the **5** red hose to either port on the **2** crawler.
5. Route the **3** umbilical, **4** blue hose and the **5** red hose through the **6** HT cable management. (see *Hose Connection and Routing* on page 82 for additional details).
6. Attach a configured **1** flange probe holder frame (see "Pivoting Probe Holder Frame - Flange Scanning" on page 76) to the **2** crawler (see "Swivel Mount" on page 41).

## 5.6. Crawler

### 5.6.1. Swivel Mount

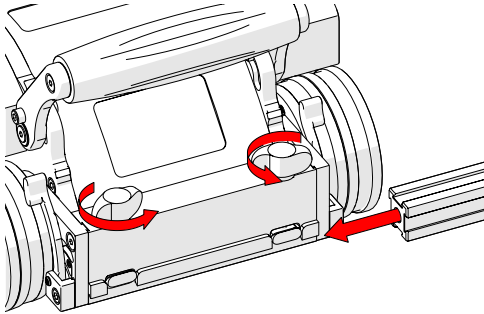

Fig. 52 - Frame bar installation

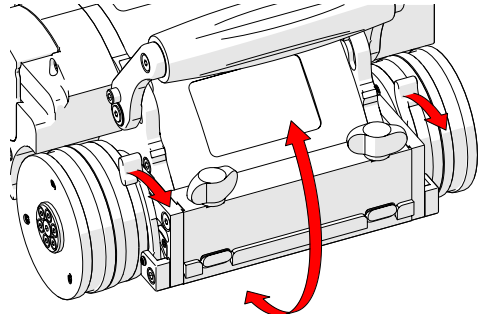

Fig. 53 - Swivel mount angle

Located at the front of the crawler, the swivel mount is used to connect scanning accessories such as a Raster Arm HT module, probe frame system or corrosion thickness probe holder.

Rotate the two black wing knobs (*Fig. 52*) to loosen the dovetail jaws. Slide the accessory's frame bar along the dovetail jaws. Rotate the two black wing knobs to clamp the frame system/Raster Arm HT in place.

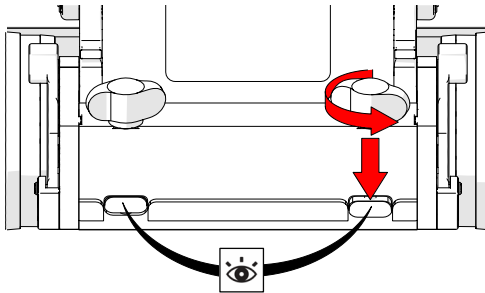

Fig. 54 - Align dovetail jaws

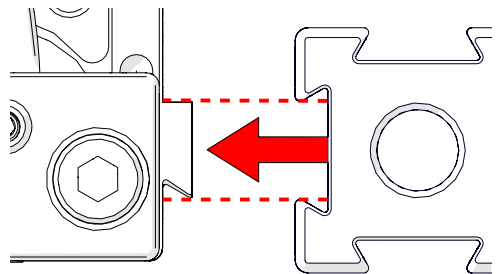

Fig. 55 - Mount frame bar

Alternatively, accessories can also be mounted straight to the swivel mount. Rotate the black wing knobs aligning the dovetail jaws with the mount's grooves (*Fig. 54*). Press the frame bar or accessory to the swivel mount (*Fig. 55*) and tighten the black wing knobs.

The front mount utilizes two levers (*Fig. 53*) to lock the front mount at the desired angle.

The etched line (*Fig. 56*) near the base of the swivel mount can be used to align the front swivel mount to a horizontal position.

**NOTE:** The front mount must be horizontal when using the pivoting probe holder frame to scan longitudinally on piping.

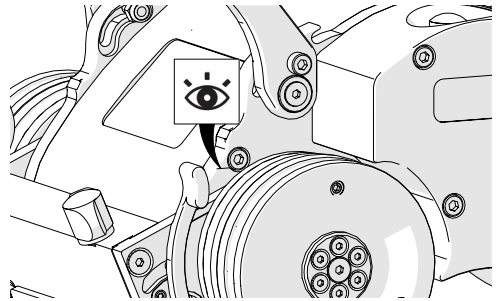

Fig. 56 - Return mount to horizontal position

## 5.6.2. Umbilical



**WARNING! FALLING OBJECT HAZARD.** or operating at heights greater than 2 m (6 ft), ensure the umbilical strain relief never points upwards as shown in (*Fig. 60*). The crawler could fall. **SEVERE INJURY** or **DEATH** could result.

To mount the umbilical to the crawler, follow these steps

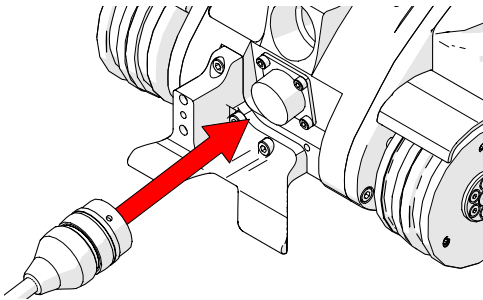

Fig. 57 - Connect to umbilical

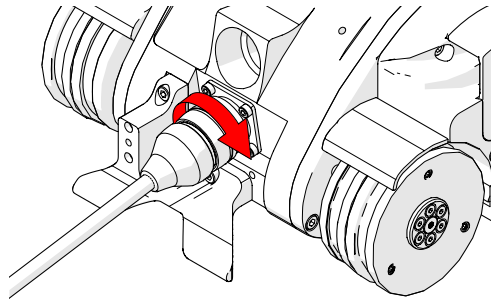

Fig. 58 - Align with crawler's umbilical mount

1. Align the pins of the umbilical to the connector at the rear of the SKOOT HT (*Fig. 57*).
2. Twist the umbilical's sleeve clockwise locking the umbilical in place (*Fig. 58*).

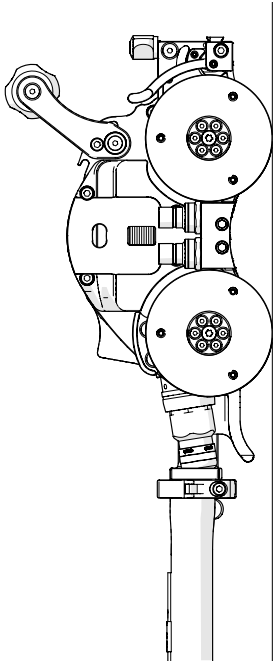

Fig. 59 - Correct umbilical use

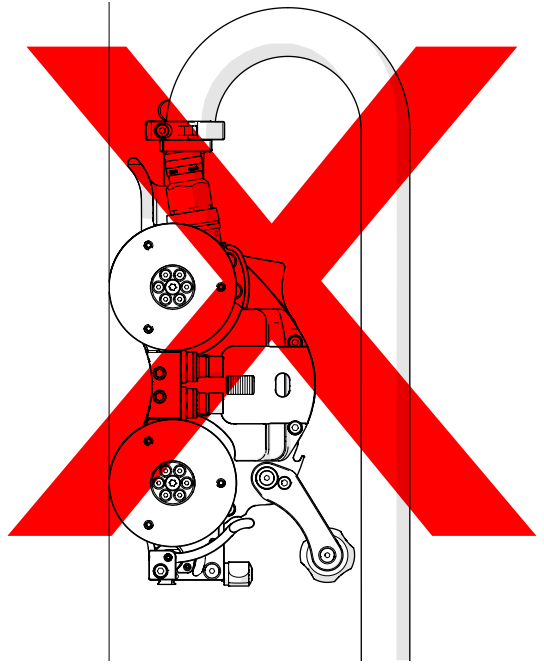

Fig. 60 - Incorrect umbilical use

3. Ensure the umbilical strain relief never points downwards during operation (Fig. 60).

### 5.6.3. Handle

The handle can be lowered to achieve low profile scanning.

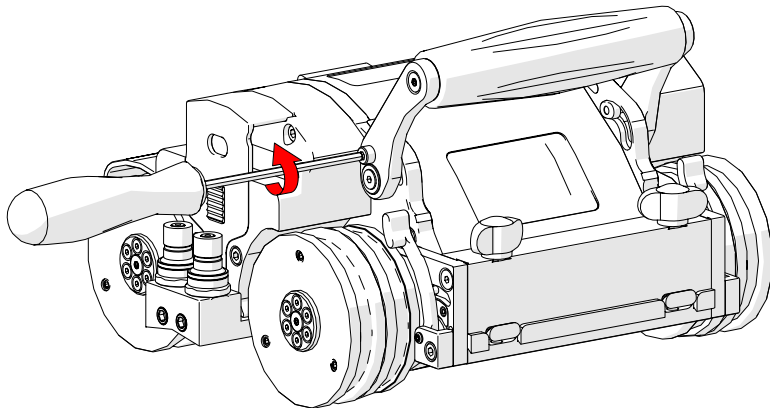

Fig. 61 - Unscrew handle lock screw

1. To lower the handle, use the supplied 3 mm driver to loosen the handle lock screws on either side of the handle (Fig. 61).

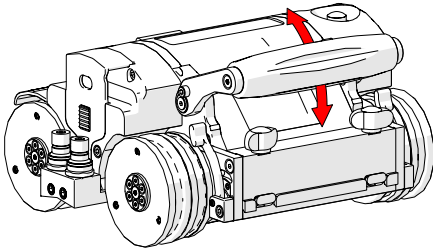

Fig. 62 - Pivot handle as desired

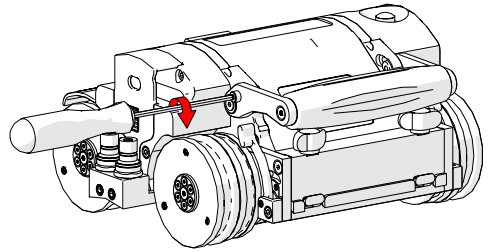

Fig. 63 - Tighten lock screws

2. Pivot the handle as required (Fig. 62).
3. Tighten the handle lock screws when complete (Fig. 63).

#### 5.6.4. Off Button

The red button located on the top left of the crawler provides an off button to the entire system. When pressed, all power to the SKOOT HT system will disengage.

To restore system power, it is necessary to press the green power button located on the system controller (see "System Controller" on page 17).

**NOTE:** Terminating system power may cause the crawler to freewheel down when operating in a vertical orientation.

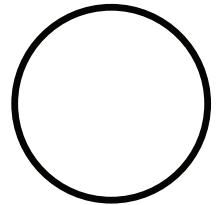

Fig. 64 - Off

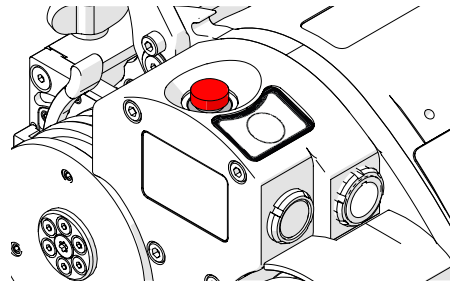

Fig. 65 - Off button

### 5.6.5. Cable Retainer

Located at the on the side of the crawler, the cable retainer offers a means of cable management for cables, hoses and tubes. Gently apply pressure to the grooves of the cable retainer and lift (Fig. 66). Route cables, hoses or tubes through the retainer and then press the cable retainer down (Fig. 67).

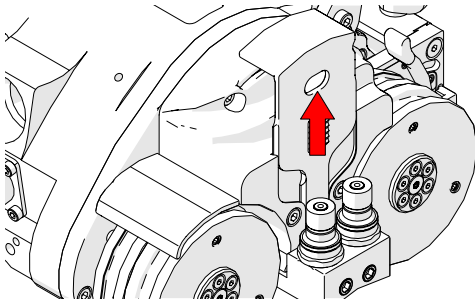

Fig. 66 - Lift retainer by hand

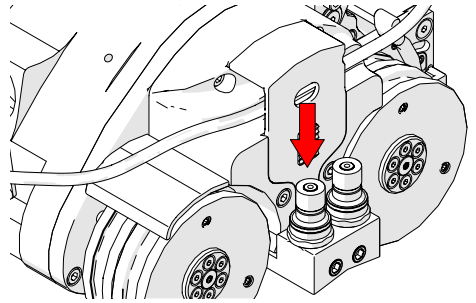

Fig. 67 - Place cables and hoses then close retainer

### 5.6.6. Manipulation Handle

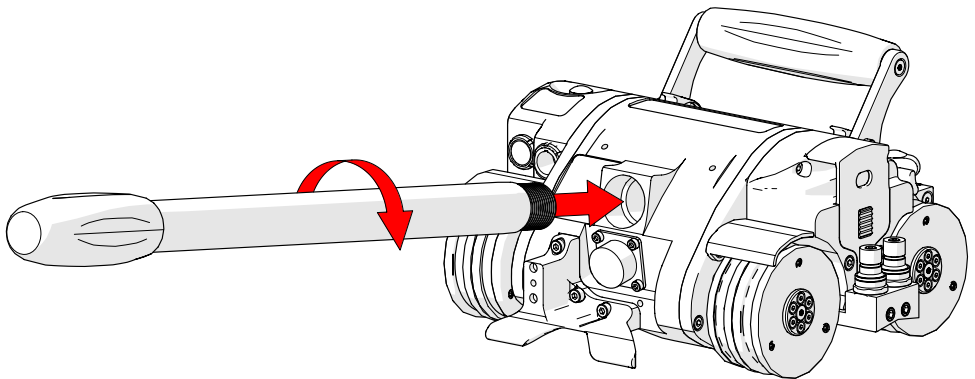

Fig. 68 - Manipulation handle

The manipulation handle (Fig. 68) provides a means of orienting the scanner direction. The handle can be used to set initial scanner direction as well as occasional orientation correction. The manipulation handle is not intended as a tool for constant adjustment during a scan operation.

The handle may be removed when additional scanner clearance is required.

### 5.6.7. Quick Connect Fitting

Located on the side of the crawler, the quick connect fittings provide a connection point for hose fittings.

Press the hose fitting onto the quick connect to attach (Fig. 69).

**TIP:** The blue and red hose may be connected to either quick connect.

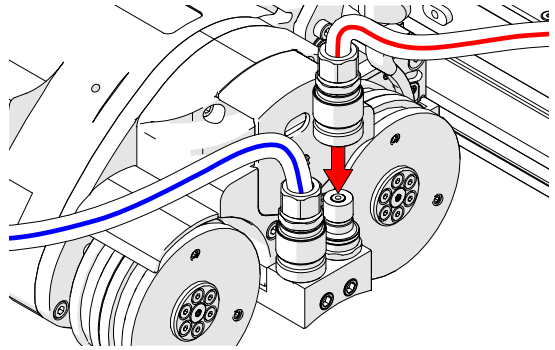

Fig. 69 - Quick connect fitting

Ensure that hoses are routed through the HT cable management system (see *Hose Connection and Routing on page 82 for additional details*).

## 5.7. Handheld Controller



**WARNING! MAGNETIC MATERIAL.** The handheld controller produces a strong magnetic field which may cause failure or permanent damage to items such as watches, memory devices, CRT monitors, medical devices or other electronics.



People with pacemakers or ICD's must stay at least 10 cm (4 in) away.



**CAUTION! DO NOT DISCONNECT UNDER LOAD.** Shut off power before connection or disconnecting. Permanent damage to electronics could occur.



### 5.7.1. Magnetic Mounts

Magnetic mounts on the rear of the handheld controller assist in preventing the handheld controller from falling.

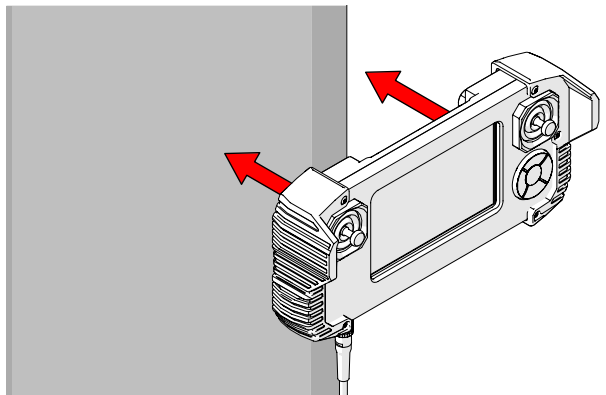

Fig. 70 - Mount to ferrous surfaces

## 5.8. Probe Holder

### 5.8.1. Heavy Duty Vertical Probe Holder

- A Latch
- B Probe Holder Arm Adjustment Knob
- C Yoke
- D Probe Holder Arms
- E Pivot Buttons
- F Arm Clamp Screw
- G Probe Holder Adjustment Knob
- H Vertical Adjustment Knob

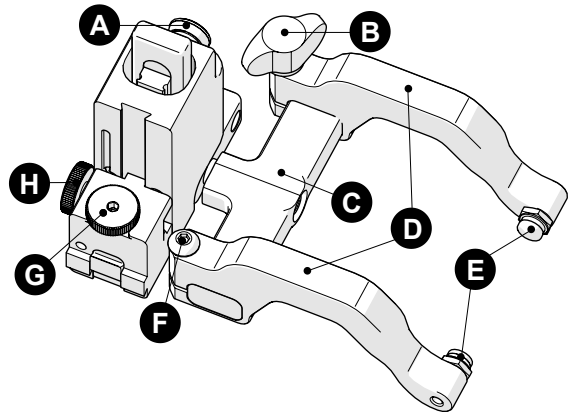

Fig. 71 - Heavy duty vertical probe holder

#### 5.8.1.1 Probe Holder Setup

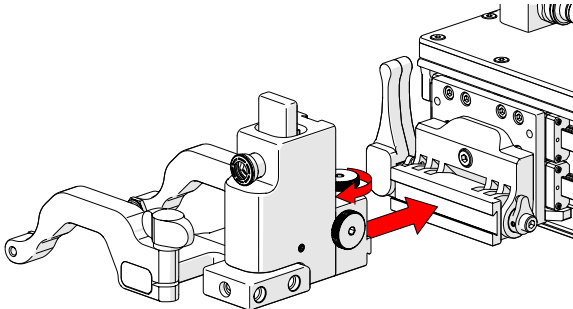

Fig. 72 - Mount probe holder to carrier

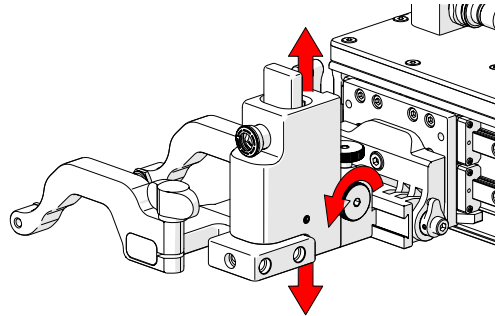

Fig. 73 - Vertical adjustment

1. Loosen the probe holder adjustment knob (*Fig. 72*) and mount the heavy duty vertical probe holder's dovetail jaw to the carrier.
2. The vertical adjustment knob (*Fig. 73*) allows the heavy duty vertical probe holder's height adjustment. This adjustment also controls the probe holders spring tension.

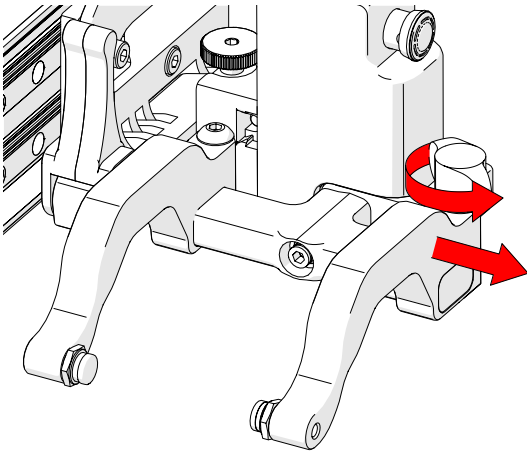

Fig. 74 - Remove outer arm

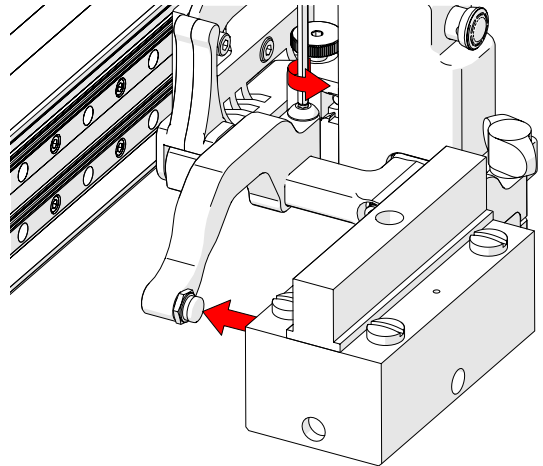

Fig. 75 - Adjust inner arm

3. Loosen the probe holder adjustment knob and remove the outer probe holder arm (Fig. 74).
4. Loosen the arm clamp screw (Fig. 75).
5. Place the wedge on the pivot button of the inner probe holder arm (Fig. 74).

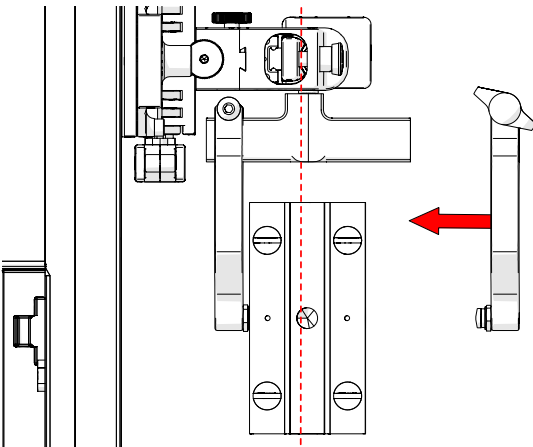

Fig. 76 - Align probe with yoke

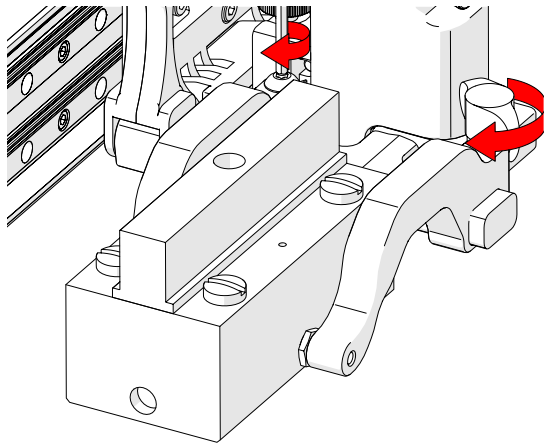

Fig. 77 - Tighten knobs and screws

6. Align the middle of the wedge with the centre of the yoke (Fig. 76).
7. Tighten both the probe holder adjustment knob and the arm clamp screw (Fig. 77) while ensuring the wedge remains centred with the yoke.

## 5.8.1.2 Probe Holder Vertical Adjustment

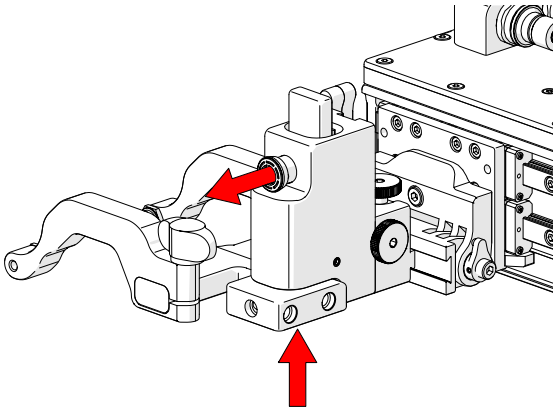

Fig. 78 - Press up and pull latch

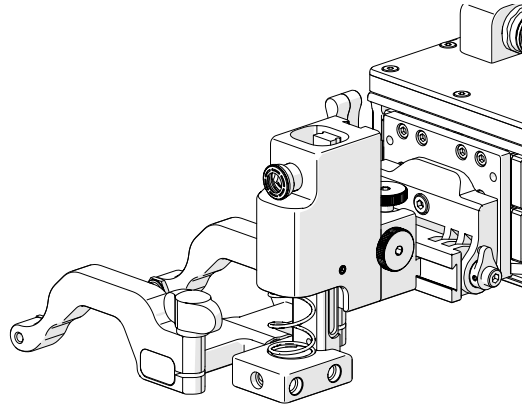

Fig. 79 - Lowered toward scan surface

1. Gently lift the heavy duty vertical probe holder and simultaneously pull the latch (*Fig. 78*). This action will unlock the probe holder. Slowly lower the probe holder towards the scan surface (*Fig. 79*).

### 5.8.1.3 Probe Holder Left/Right Conversion

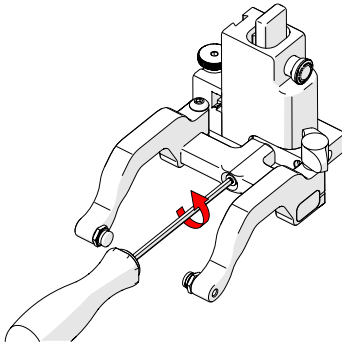

Fig. 80 - Remove yoke

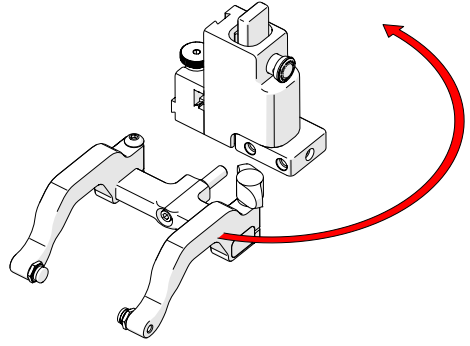

Fig. 81 - Orient to opposite side

1. Using the supplied 3 mm driver, unscrew the yoke (Fig. 80).
2. Position the yoke and arms to the opposite side of the probe holder (Fig. 81).

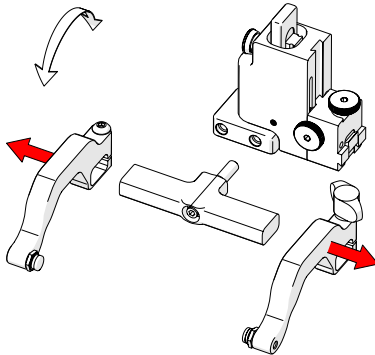

Fig. 82 - Remove probe holder arms

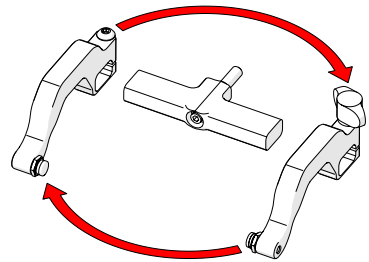

Fig. 83 - Reverse position around yoke

3. Loosen the arm clamp screw and the probe holder arm adjustment knob allowing removal of the probe holder arms (Fig. 82).
4. Position the removed arms to the opposite sides of the yoke (Fig. 83).

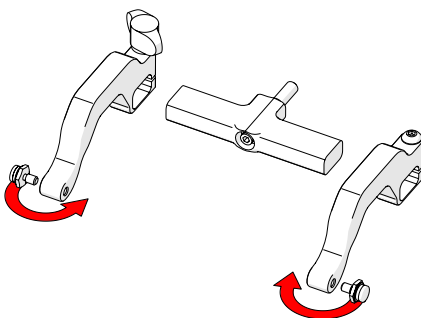

Fig. 84 - Position pivot buttons

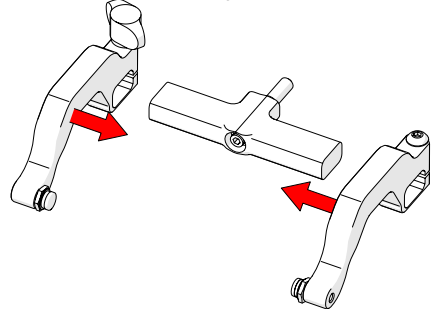

Fig. 85 - Place arms back onto yoke

5. Position the pivot buttons to the inside of the probe holder arms (Fig. 84).
6. Place the probe holder arms on the yoke and tighten the arm clamp screw and probe holder adjustment knob (Fig. 85).
7. Screw the yoke to the probe holder (Fig. 86).

**TIP:** When using a standard yoke length, position the yoke in the threaded hole closest to the frame bar. When using a wide yoke length, position the yoke in the threaded hole furthest from the frame bar.

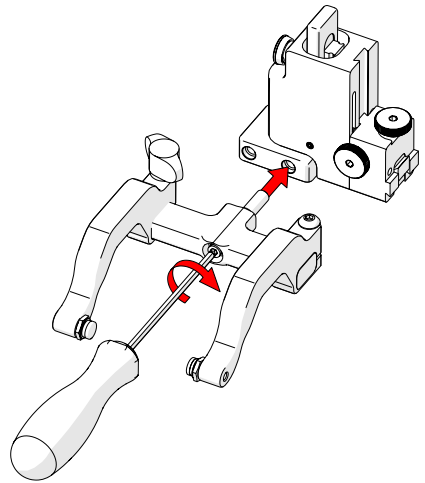

Fig. 86 - Screw into threaded hole

#### 5.8.1.4 Probe Holder 90° Adjustment

1. Remove the yoke using the supplied 3 mm hex driver (Fig. 80).
2. Orient the yoke to the front of the probe holder and screw the yoke into the threaded hole provided (Fig. 87).

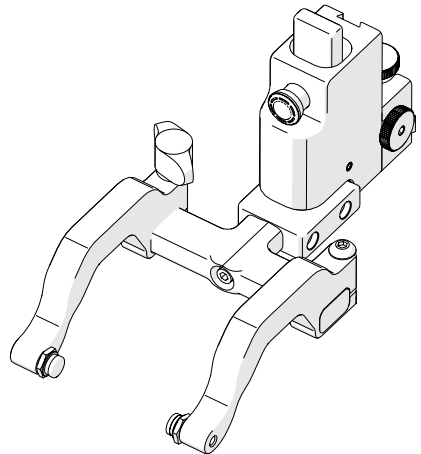

Fig. 87 - 90° probe holder positioning

## 5.8.2. Vertical Probe Holder

- A Latch
- B Probe Holder Adjustment Knob
- C Vertical Adjustment Knob
- D Pivot Buttons
- E Probe Holder Arms
- F Yoke
- G Probe Holder Arm Adjustment Knob
- H Transverse Adjustment Screw
- I Frame Bar

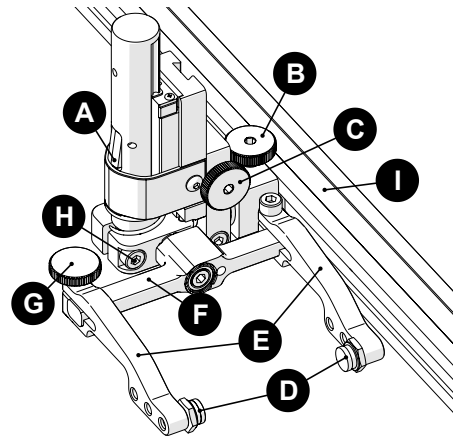

Fig. 88 - Vertical probe holder

### 5.8.2.1 Probe Holder Setup

To mount a UT wedge in the probe holder, follow these steps

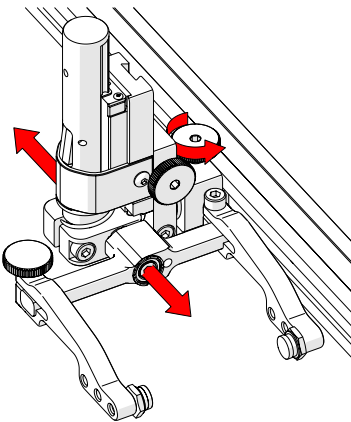

Fig. 89 - Adjust on frame bar

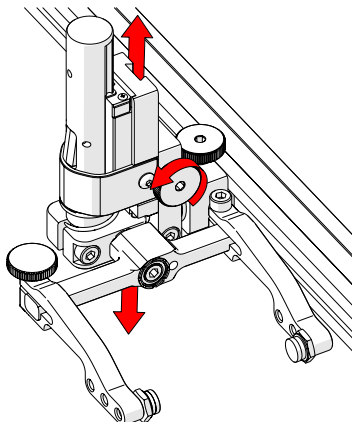

Fig. 90 - Vertical adjustment

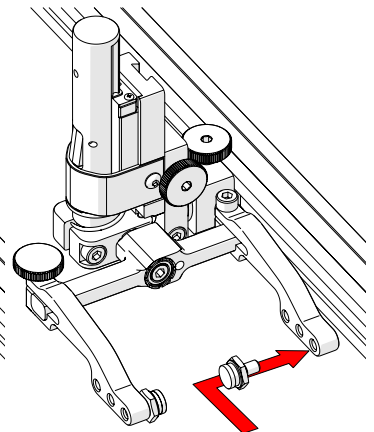

Fig. 91 - Place buttons

1. The probe holder adjustment knob allows the probe holder to be attached to a frame bar, as well as horizontal positioning on a frame bar (Fig. 89).
2. The vertical adjustment knob allows the vertical probe holder height adjustment (Fig. 90).
3. Position the pivot buttons where necessary. When a narrow scanning footprint is required, use the pivot button holes closest to the yoke (Fig. 91).

**TIP:** Probe pivoting may be impeded when closer to the yoke.

To mount a UT wedge in the probe holder, follow these steps:

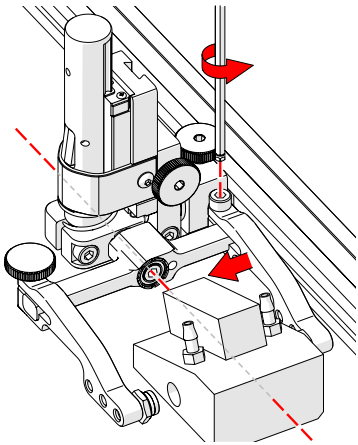

Fig. 92 - Adjust inner arm

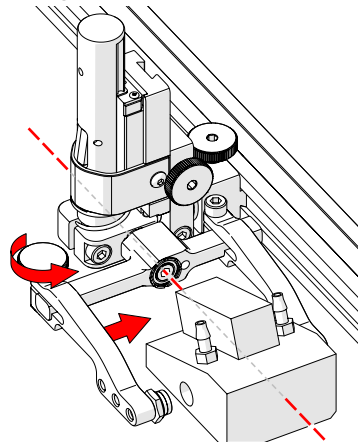

Fig. 93 - Adjust outer arm

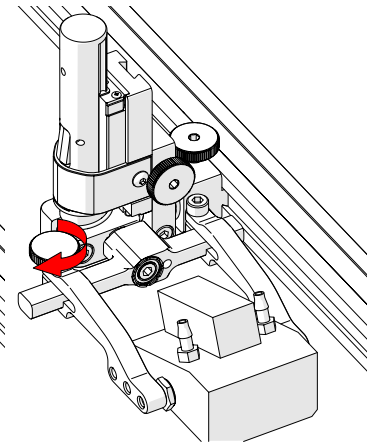

Fig. 94 - Tighten arm knob

4. Position the wedge on the inner probe holder arm (Fig. 92).

**TIP:** The probe holder yoke can accommodate many different probe and wedge sizes of varying widths. It is best to centre the wedge with the yoke's pivot axis. This can reduce wedge 'rocking' when scanning. Position the inner probe holder arm accordingly (Fig. 92) using the supplied 3 mm hex driver (Fig. 39).

5. Loosen the probe holder arm adjustment knob (Fig. 93) and slide the probe holder arm along the yoke pinching the wedge in place.
6. Tighten the probe holder arm adjustment knob (Fig. 94).

### 5.8.2.2 Probe Holder Vertical Adjustment

To adjust the probe holder vertically, follow these steps:

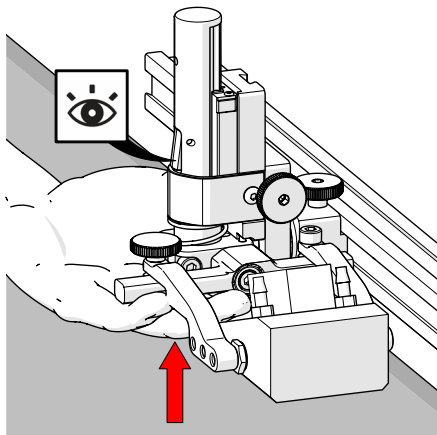

Fig. 95 - Latch probe holder

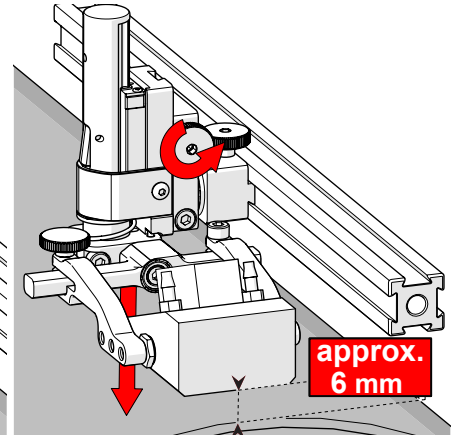

Fig. 96 - Lower toward scan surface

1. Ensure the probe holder is in the latched, upper position. Lift the probe holder until the latch is fully exposed and snaps out to lock (Fig. 95).
2. Loosen the vertical adjustment knob and slide the probe holder down until the wedge is approximately 6 mm ( $\frac{1}{4}$  in) above inspection surface.
3. Tighten the vertical adjustment knob (Fig. 96).

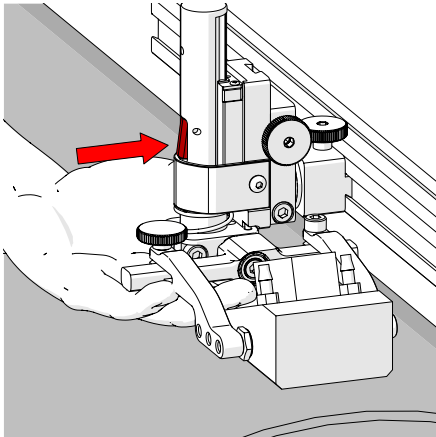

Fig. 97 - Press latch button

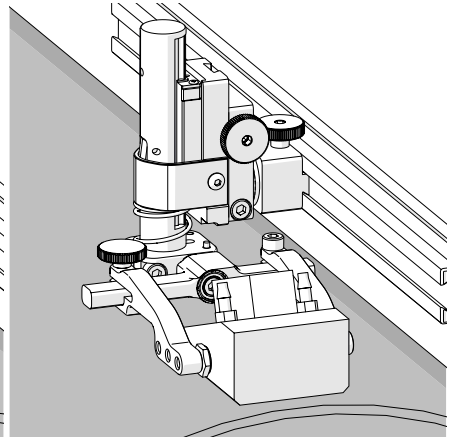

Fig. 98 - Lower toward scan surface

4. Lift the yoke slightly and press the latch button (Fig. 97), then slowly lower towards scanning surface to apply spring pressure to the wedge (Fig. 98).

**TIP:** If less spring force is desired, refer to step 2 and place the wedge approximately 20 mm ( $\frac{3}{4}$  in) above inspection surface.

### 5.8.2.3 Probe Holder Transverse Adjustment

To adjust the probe holder's transverse angle, follow these steps:

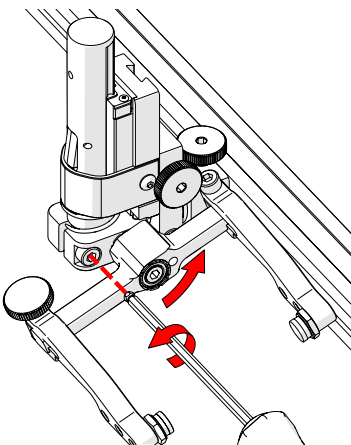

Fig. 99 - Loosen 3 mm screw

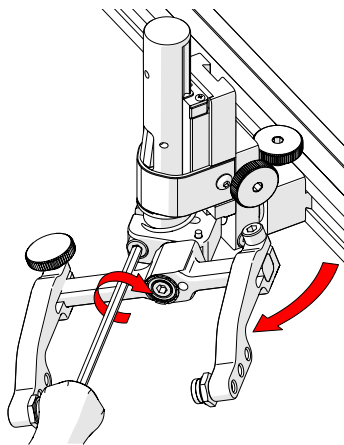

Fig. 100 - Rotate and tighten

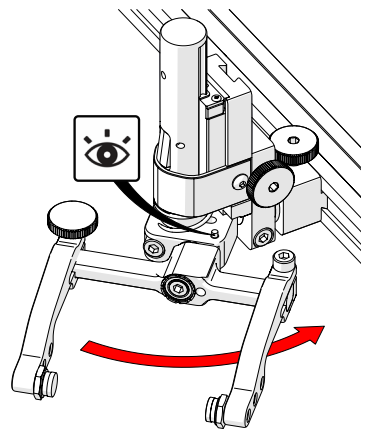

Fig. 101 - Stop post locates 90°

1. Ensure the probe holder is in latched, upper position (*Fig. 95*).
2. Using the supplied 3 mm hex driver loosen the transverse adjustment screw (*Fig. 99*) and rotate the yoke about the vertical shaft achieving the desired angle.
3. Tighten the transverse adjustment screw (*Fig. 100*).

To return the transverse adjustment to neutral ( $90^\circ$ ). The probe holder must be in the latched, upper position (*Fig. 95*). Rotate the yoke until the stop post contacts the base of the probe holder (*Fig. 101*). Then tighten the transverse adjustment screw.

#### 5.8.2.4 Probe Holder Longitudinal Adjustment

To adjust the probe holder's vertical angle for longitudinal scanning, follow these steps:

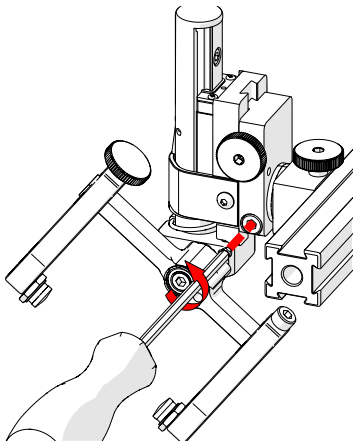

Fig. 102 - Loosen 3 mm screw

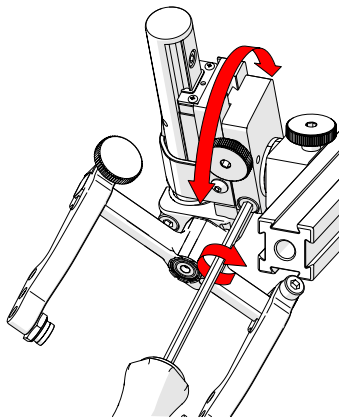

Fig. 103 - Rotate to position

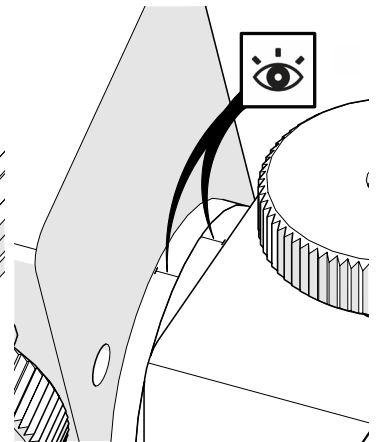

Fig. 104 - Line up markers

1. Ensure the probe holder is in latched, upper position (*Fig. 95*).
2. Using the supplied 3 mm hex driver (*Fig. 39*), loosen the longitudinal adjustment screw (*Fig. 102*).
3. Rotate the main body of the probe holder until it is at the desired angle (*Fig. 103*).
4. Tighten the longitudinal adjustment screw (*Fig. 103*).

To return the longitudinal adjustment to neutral ( $90^\circ$ ). Line up the longitudinal adjustment indicator markers (*Fig. 104*).

### 5.8.2.5 Probe Holder Left/Right Conversion

To reverse the probe holder, follow these steps:

**NOTE:** To perform this operation the 1.5 mm hex wrench (Fig. 42) is required.

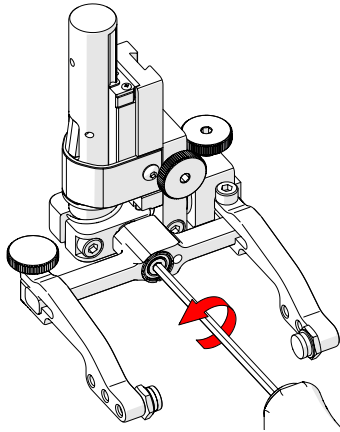

Fig. 105 - Unscrew yoke pivot screw

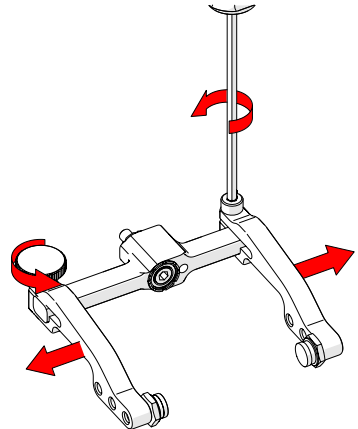

Fig. 106 - Remove probe holder arms

1. Ensure the probe holder is in latched, upper position (Fig. 95).
2. Using the supplied 3 mm hex driver (Fig. 39), unscrew the yoke pivot screw and remove yoke (Fig. 105).
3. Loosen the probe holder arm adjustment knob and the arm clamp screw. Slide the probe holder arms off the yoke (Fig. 106).

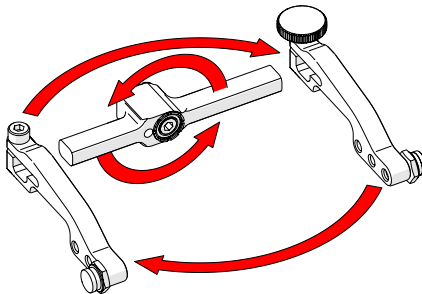

Fig. 107 - Flip yoke and reverse arms

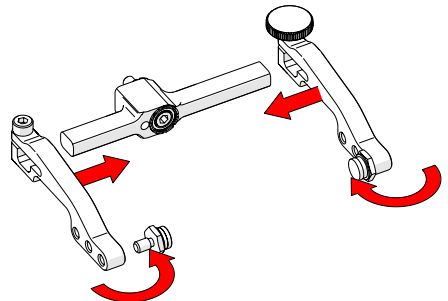

Fig. 108 - Attach arms & move buttons

4. Flip the yoke 180° and reverse the probe holder arms (Fig. 107).
5. Place the pivot buttons on the inside of the probe holder arms (Fig. 108) using a 3/8 in wrench (Fig. 40).

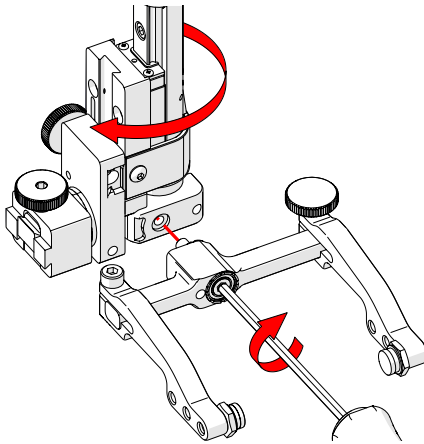

Fig. 109 - Screw yoke to opposite side

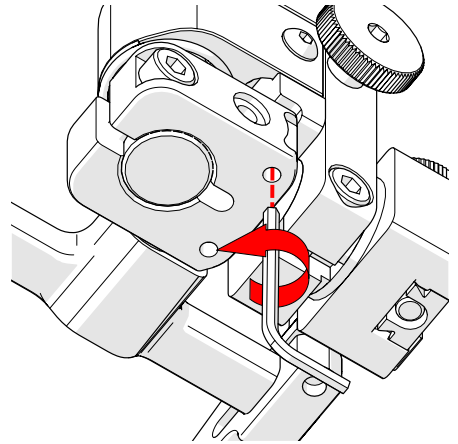

Fig. 110 - Lower 90° stop post

6. Mount the yoke to the opposite side of the base using the supplied 3 mm hex driver (Fig. 109).

**TIP:** Keep the yoke level with the base as to ensure no conflicts with the plunger/set screw attached to the yoke.

7. Locate the recessed M3 screw on the bottom of the probe holder. Unscrew the stop post using a 1.5 mm hex wrench (Fig. 42) until it has cleared all obstructions. Do not remove stop post (Fig. 110).

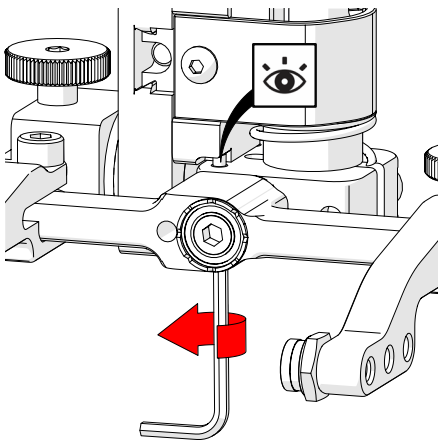

Fig. 111 - Raise opposite 90° stop post

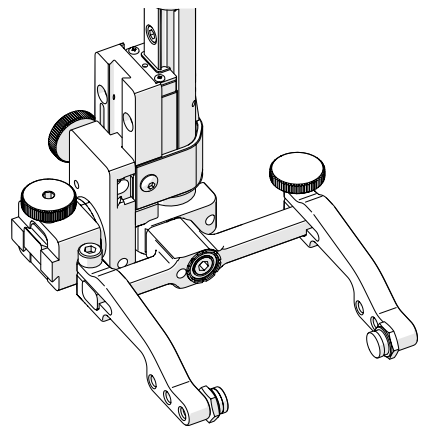
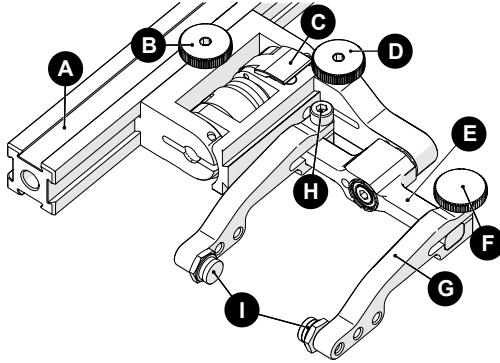

Fig. 112 - Reversed probe holder

8. Raise the stop post on the opposite side until the side of the post clearly contacts the 90° stop point on the probe holder's base (Fig. 111).

### 5.8.3. Slip Joint Probe Holder



|   |                                  |
|---|----------------------------------|
| A | Frame Bar                        |
| B | Probe Holder Adjustment Knob     |
| C | Latch                            |
| D | Swing Arm Knob                   |
| E | Yoke                             |
| F | Probe Holder Arm Adjustment Knob |
| G | Probe Holder Arm                 |
| H | Arm Clamp Screw                  |
| I | Pivot Buttons                    |

Fig. 113 - Slip Joint Probe Holder

#### 5.8.3.1 Probe Holder Setup

To mount a UT wedge in the probe holder, follow these steps:

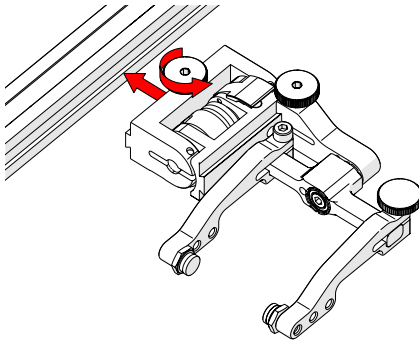

Fig. 114 - Attach to frame bar

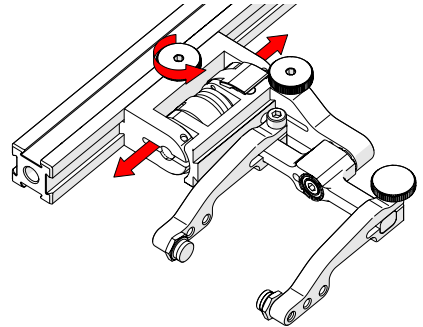

Fig. 115 - Adjust on frame bar

1. Rotate the probe holder adjustment knob and attach probe holder to a frame bar (Fig. 114).
2. Use the probe holder adjustment knob to position the probe holder along the frame bar (Fig. 115).

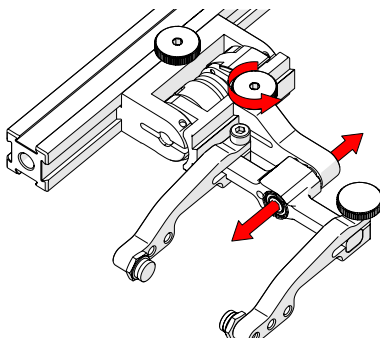

Fig. 116 - Adjust swing arm

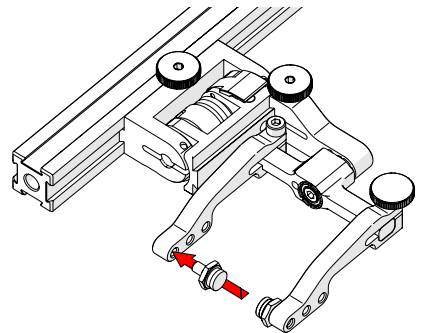

Fig. 117 - Place pivot buttons

3. Use swing arm knob to position the swing arm (Fig. 116).

**TIP:** The swing arm is typically used to adjust TOFD center to center distance relative to the phased array probes on a four probe configuration.

4. Using the supplied 3/8 in wrench, place the pivot buttons (Fig. 117) farthest from the yoke for maximum wedge clearance.

**TIP:** If narrow scanning footprint is required, use pivot button holes closest to the yoke. Wedge pivoting may be impeded when closer to the yoke.

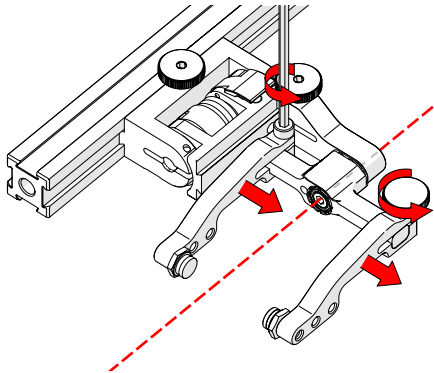

Fig. 118 - Adjust probe holder arms

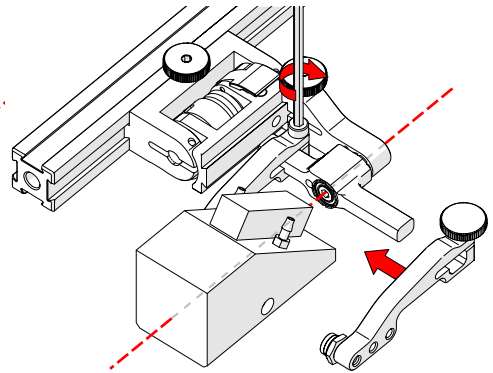

Fig. 119 - Place wedge

5. Loosen the probe holder arm adjustment knob (Fig. 118) and remove outer probe holder arm from yoke.
6. Adjust inner probe holder arm as required to best centre the probe on the yoke's pivot axis (Fig. 118).

**TIP:** The probe holder yoke can accommodate many different probe and wedge sizes of varying widths. It is best to centre the wedge with the yoke's pivot axis to reduce wedge tipping when scanning. Position the inner probe holder arm accordingly with the centre of the yoke (Fig. 118).

7. Position the wedge on the inner probe holder arm (Fig. 119).
8. Slide outer probe holder arm along the yoke pinching the wedge in place.
9. Tighten probe holder arm adjustment knob (Fig. 120).

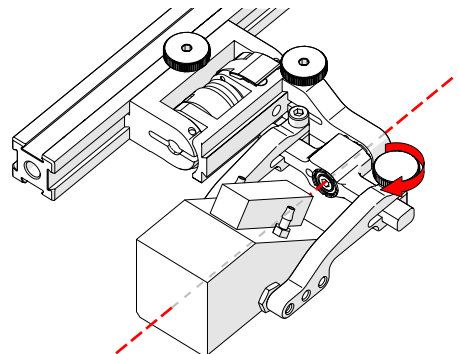

Fig. 120 - Pinch wedge with arm

### 5.8.3.2 Probe Holder Adjustment

To adjust the probe holder, follow these steps:

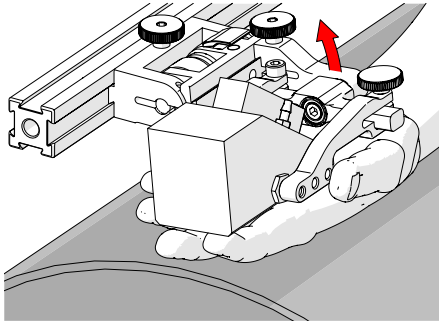

Fig. 121 - Lift to latched position

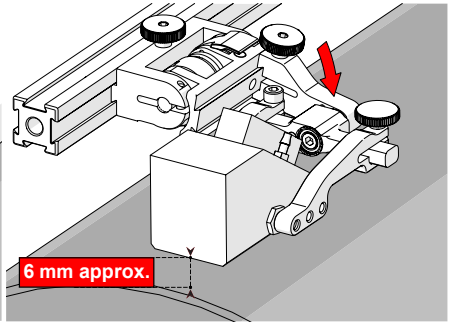

Fig. 122 - Lower to scanning surface

1. Ensure probe holder is in latched, upper position (Fig. 121). If the probe holder is already latched, it will only move within the slip joint adjustment range and have no spring tension.
2. Push the probe holder yoke down toward inspection surface until the wedge is approximately 6 mm ( $\frac{1}{4}$  in) above the inspection surface (Fig. 122).

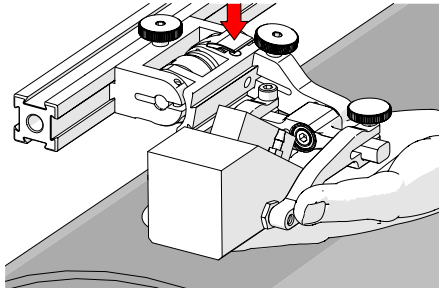

Fig. 123 - Lift and press latch button

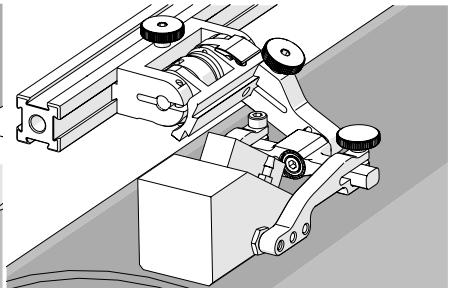

Fig. 124 - Spring loaded scan position

3. Lift probe slightly and press latch button (Fig. 123) to apply spring pressure to the wedge.
4. Gently lower probe holder and wedge to the scanning surface (Fig. 124).

### 5.8.3.3 Probe Holder Force Adjustment

It is possible to adjust the tension of the probe holder spring.

**NOTE:** To perform this operation the 2 mm hex wrench (Fig. 43) and 3 mm hex wrench (Fig. 44) is required.

|        |      |      |
|--------|------|------|
| Light  | 1 kg | 2 lb |
| Medium | 2 kg | 4 lb |
| Heavy  | 3 kg | 6 lb |

When configured correctly, these settings exert the indicated spring force on the Probe.

To adjust the probe holder's force, follow these steps:

**NOTE:** Do not perform this operation on scanning surface.

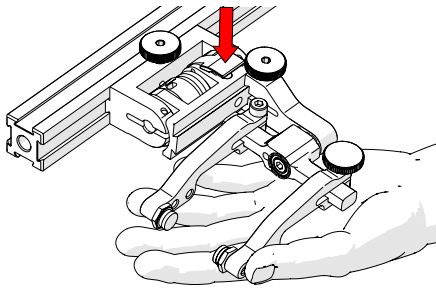

Fig. 125 - Lift slightly and press Latch

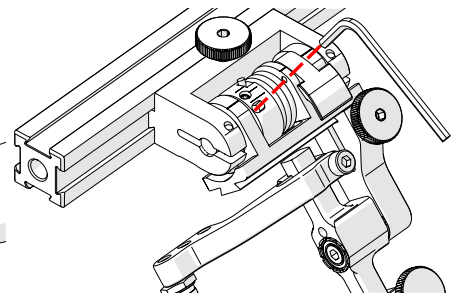

Fig. 126 - Unlatched position

1. Ensure the probe holder is in the upright latched position (Fig. 121).
2. Lift probe holder slightly and press the latch button (Fig. 125) to release the probe holder the full 45° degrees.
3. Insert the short arm of a 3 mm hex wrench into the 3 mm slot (Fig. 126).

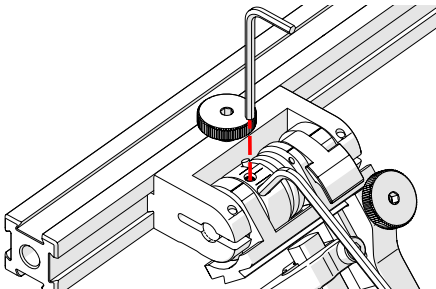

Fig. 127 - Insert hex tools

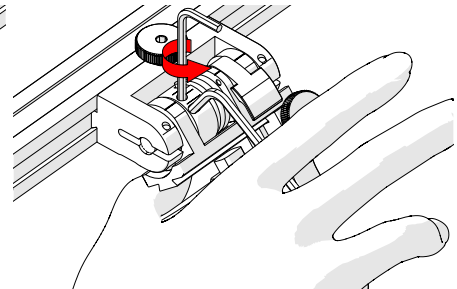

Fig. 128 - Press 3 mm hex wrench down

4. Place the 2 mm hex wrench into the force adjustment screw (Fig. 127).
5. Lightly press the long arm of the 3 mm hex wrench down. Using the 2 mm hex wrench, loosen the force adjustment screw but do not remove it (Fig. 128).
6. Gently apply pressure on the long leg of the 3 mm hex wrench until the force adjustment marker lines up with the desired spring tension. While keeping the markers in line, tighten the force adjustment screw.

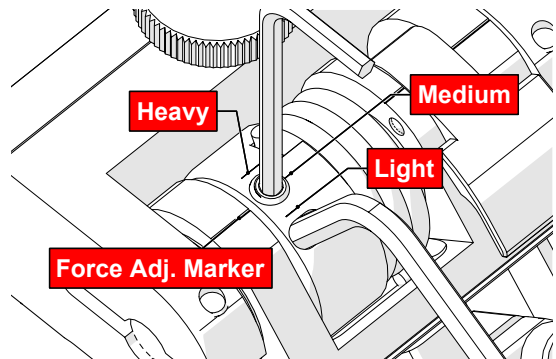

Fig. 129 - Choose desired tension

### 5.8.3.4 Slip Joint Probe Holder Left/Right Conversion

To reverse the probe holder, follow these steps:

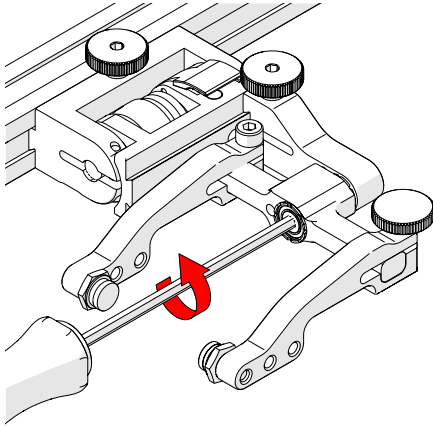

Fig. 130 - Unscrew yoke pivot screw

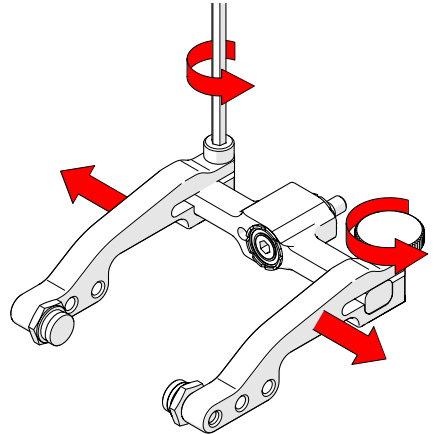

Fig. 131 - Remove arms

1. Unscrew the yoke from the swing arm (Fig. 130).
2. Loosen the probe holder arm adjustment knob and arm clamp screw. Slide the arms from the yoke (Fig. 131).

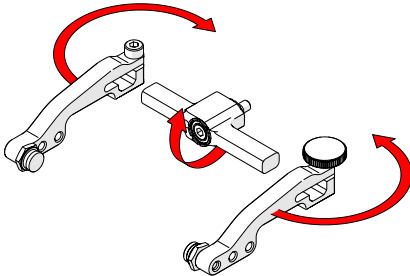

Fig. 132 - Flip yoke and reverse arms

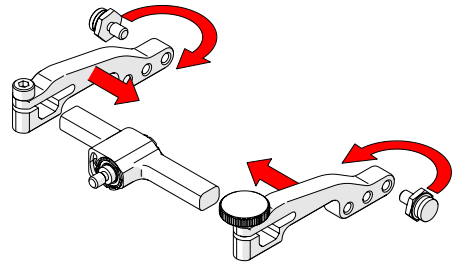

Fig. 133 - Attach arms and move buttons

3. Flip the yoke 180° and reverse the probe holder arms (Fig. 132).
4. Place the pivot buttons on the inside of the probe holder arms (Fig. 133) using a 3/8 in wrench (Fig. 40). Slide the arms onto the yoke and tighten the probe holder arm adjustment knob and the arm clamp screw.

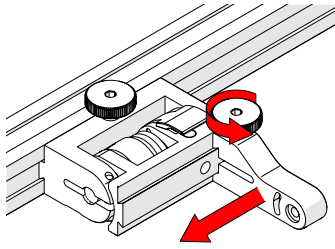

Fig. 134 - Position swing arm

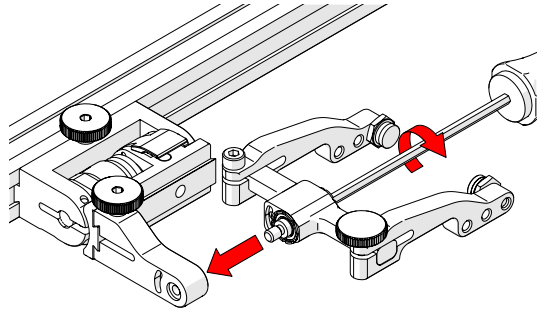

Fig. 135 - Install yoke to swing arm

5. Loosen the swing arm knob and slide the swing arm to the opposite end of the probe holder bracket (Fig. 134) or preferred position. Tighten swing arm knob.
6. Using the 3 mm hex driver, screw the yoke pivot screw into the opposite side of the probe holder swing arm (Fig. 135). Ensure the yoke is level to avoid issues with the plunger/set screw.

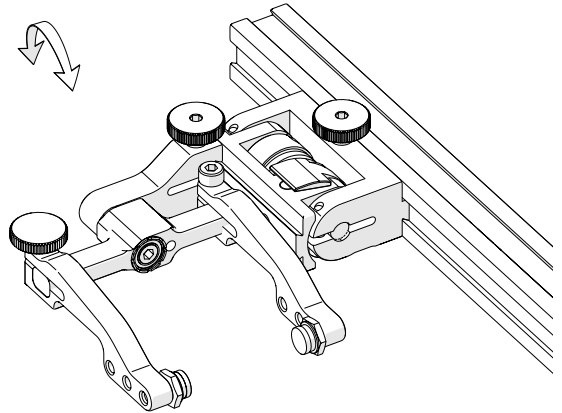

Fig. 136 - Reversed probe holder

## 5.9. Probe Holder Frames

### 5.9.1. Low Profile Probe Holder Frame - Flat or Circumferential Only



#### **WARNING! FALLING OBJECT HAZARD.**

It is imperative that the steps below be followed to properly set the height of the probe holder frame. If the height of the probe holder frame is set too low, the crawler may fall and **SEVERE INJURY** or **DEATH** could result.

The low profile frame adds weld scanning capability to the SKOOT HT motorized scanner. This frame can utilize (4) slip joint probe holders (2 Phased Array and 2 TOFD, typically). The low profile design of this frame allows for scanning on diameters where radial clearance is limited.

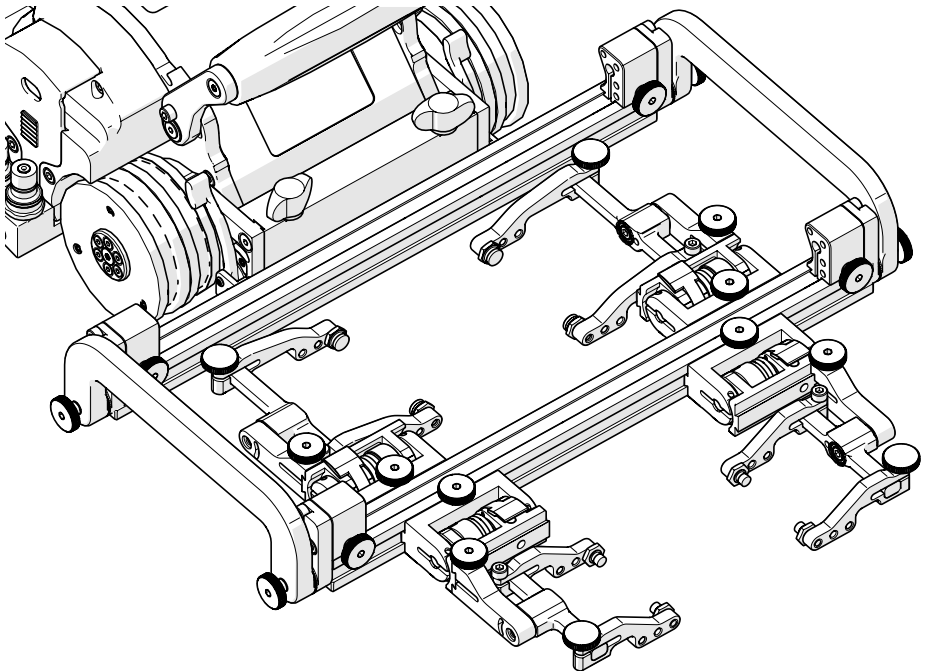

Fig. 137 - Low profile probe holder frame

1. Attach the wedges to the probe holders that are to be used (see *Probe Holder Setup* on page 58 for additional details).

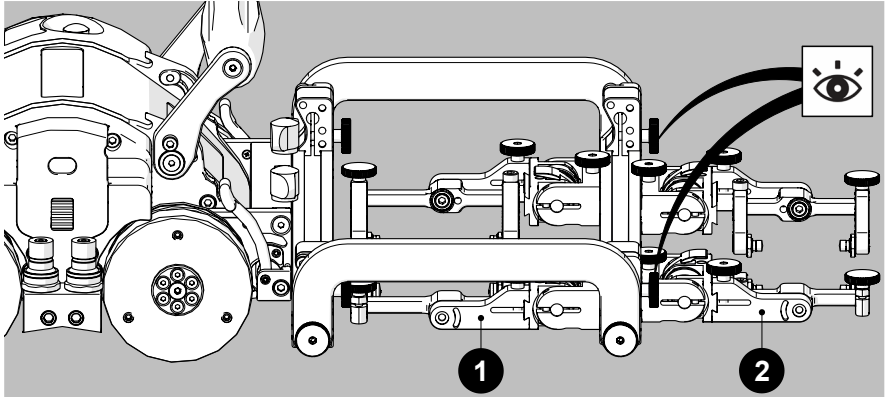

Fig. 138 - Position primary and secondary probe holders

2. Affix the probe holders (with attached wedges) to the low profile probe holder frame. On the frame bar, place the secondary probe holders at the front (Fig. 138-2) and the primary probe holders at the rear (Fig. 138-1).

**TIP:** Due to their larger size, scan results are generally improved when pulling or dragging phased array wedges.

3. Mount the low profile probe holder frame to the crawler (see *Cable Retainer* on page 45 for additional details). When mounting the low profile frame, ensure the attachment knobs (Fig. 138) are at the front (non crawler side).

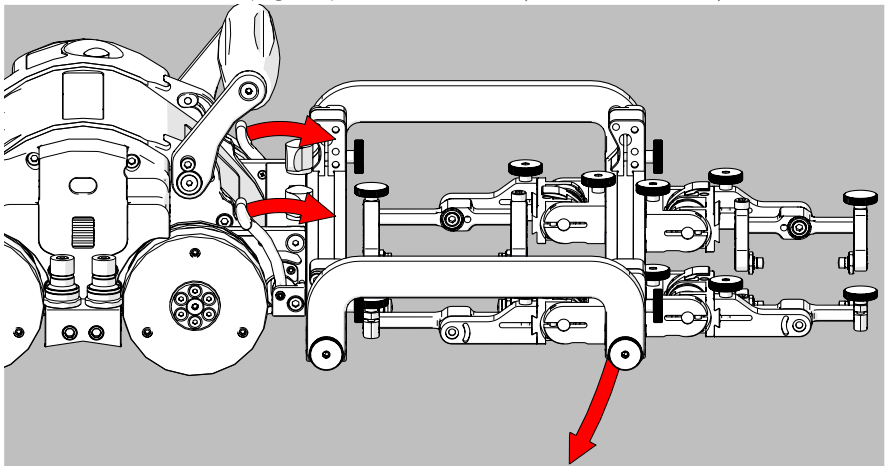

Fig. 139 - Align swivel mount with scan surface

4. Release the two swivel mount levers (Fig. 139) to position the swivel mount parallel to the scan surface (Fig. 140). When alignment with scan surface is achieved, lock the crawler swivel mount levers.

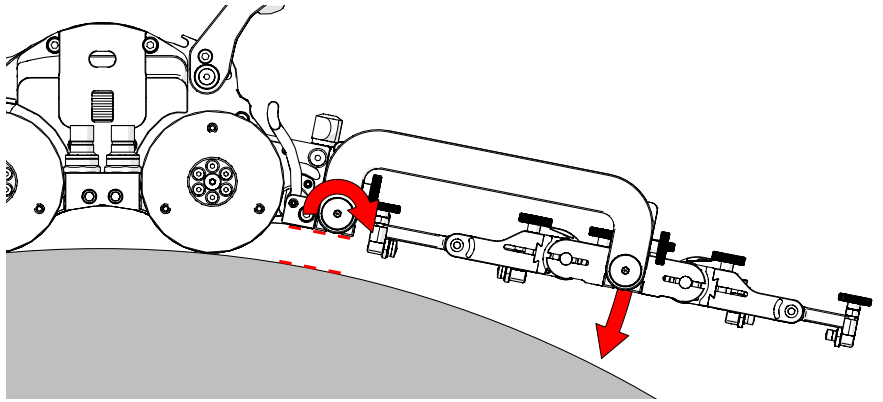

Fig. 140 - Set rear rotational adjustment knob

5. Loosen the rear rotational adjustment knob to lower the front frame bar of the low profile frame towards the inspection surface (Fig. 140).

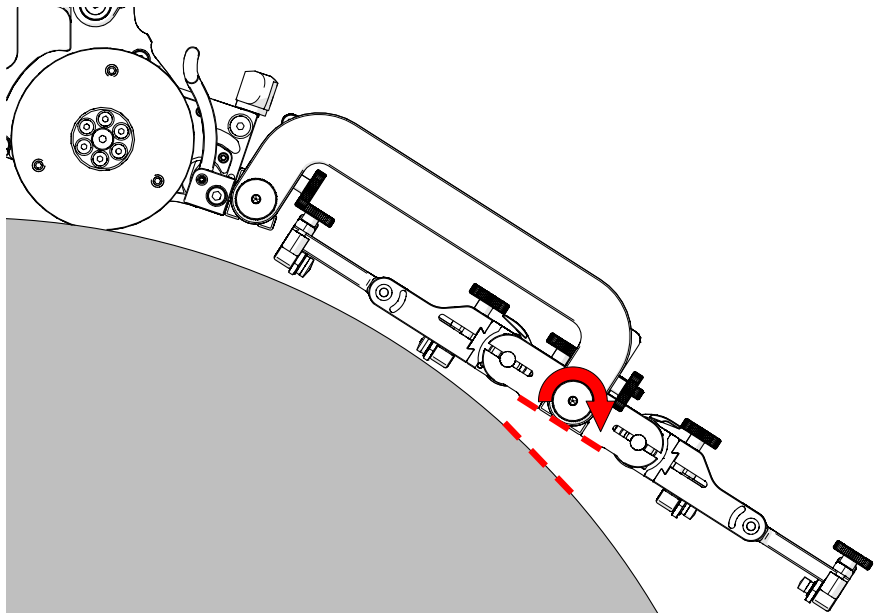

Fig. 141 - Align probe holder tangent with scan surface

6. Loosen the front rotational adjustment knob (Fig. 141) to align the frame bar parallel with the scan surface (Fig. 142).

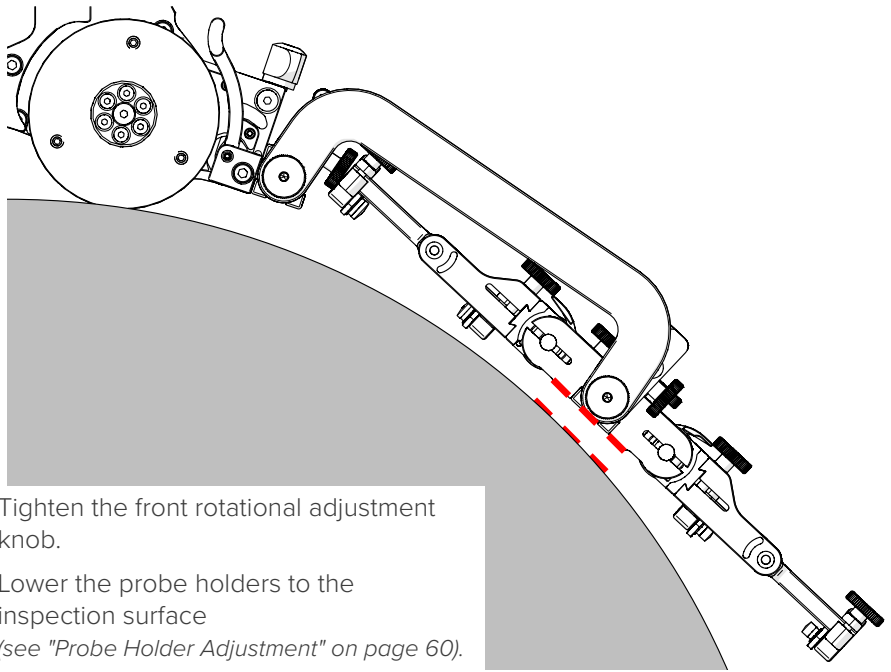

Fig. 142 - Low profile probe holder frame

## 5.9.2. Vertical Probe Holder Frame - Flat or Circumferential Only



### **WARNING! FALLING OBJECT HAZARD.**

It is imperative that the steps below be followed to properly set the height of the probe holder frame. If the height of the probe holder frame is set too low, the crawler may fall and **SEVERE INJURY** or **DEATH** could result.

The vertical probe holder frame adds weld scanning capability to the SKOOT HT motorized scanner. This frame uses (4) vertical probe holders. Additional frame components allow up to six probes to be used (contact Jireh Industries Ltd. on page 1).

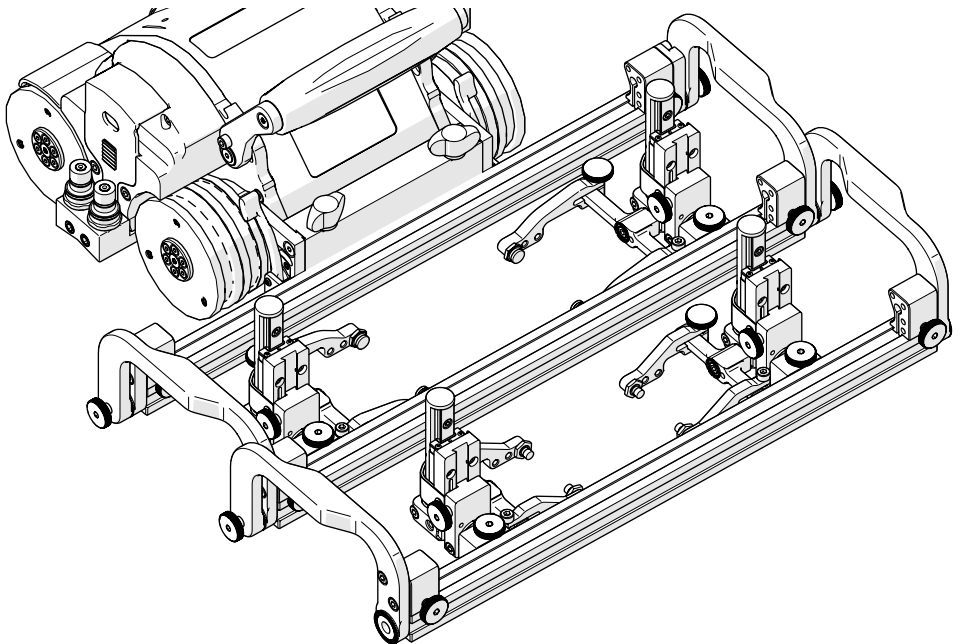

Fig. 143 - Vertical probe holder frame

1. Attach the wedges to the probe holders that will be used (see *Probe Holder Setup* on page 52 for additional details).

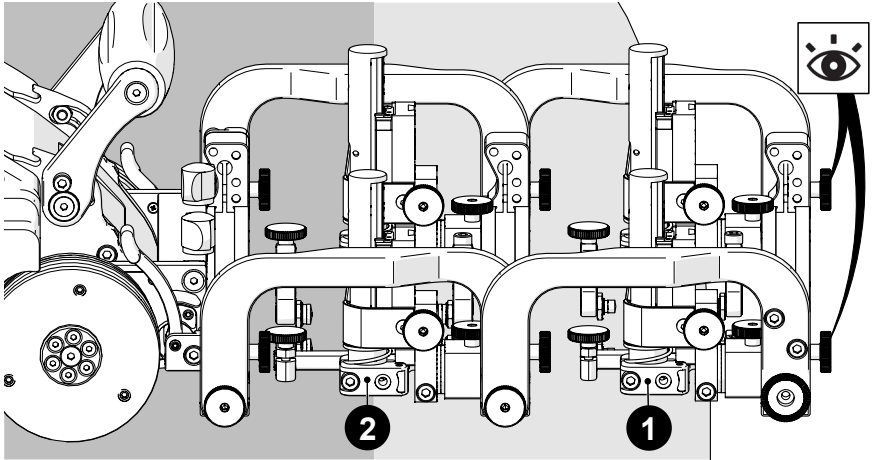

Fig. 144 - Position primary and secondary probe holders

2. Affix the probe holders (*with attached wedges*) to the probe holder frame. Place the secondary probe holder at the front of the frame (*Fig. 144-1*) and place the primary probe holders at the rear of the frame bar (*Fig. 144-2*).

**TIP:** Due to their larger size, scan results are generally improved when pulling or dragging phased array wedges.

3. Mount the probe holder frame to the crawler (*see Cable Retainer on page 45 for additional details*). When mounting the probe holder frame, ensure the attachment knobs (*Fig. 145*) are at the front (*non crawler side*).

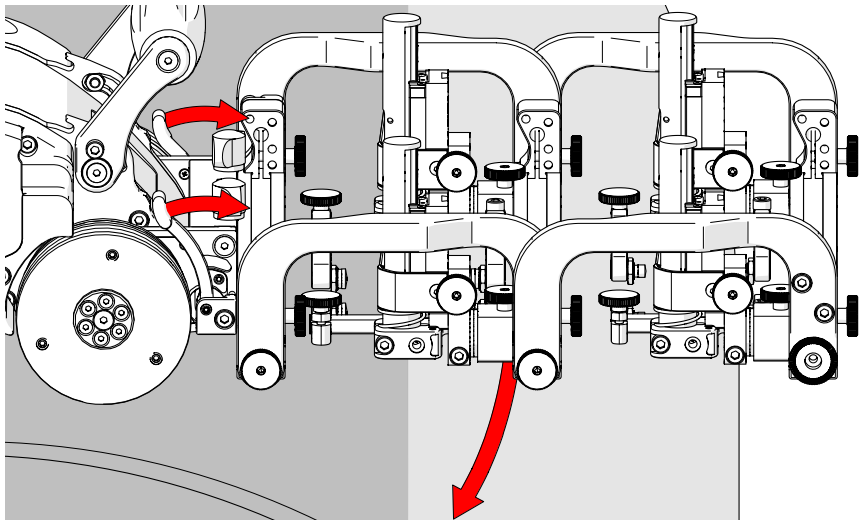

Fig. 145 - Align swivel mount with scan surface

4. Release the two swivel mount levers (*Fig. 145*) to position the swivel mount parallel to the scan surface (*Fig. 146*). When alignment with scan surface is achieved, lock the crawler swivel mount levers.

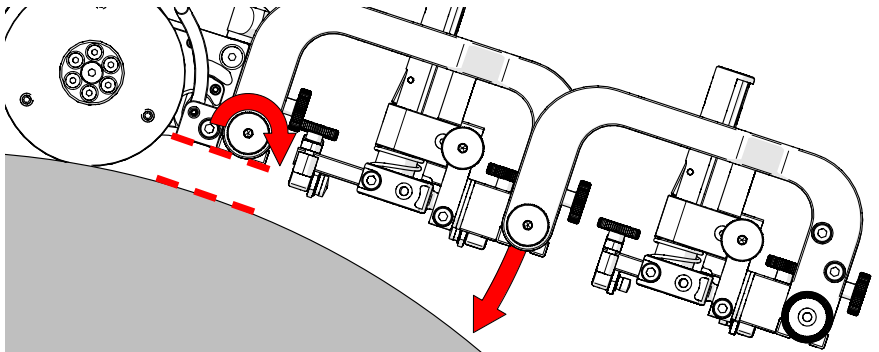

Fig. 146 - Set rear rotational adjustment knob

5. Loosen the rear rotational adjustment knob to lower the weld scan frame towards the inspection surface (*Fig. 146*).

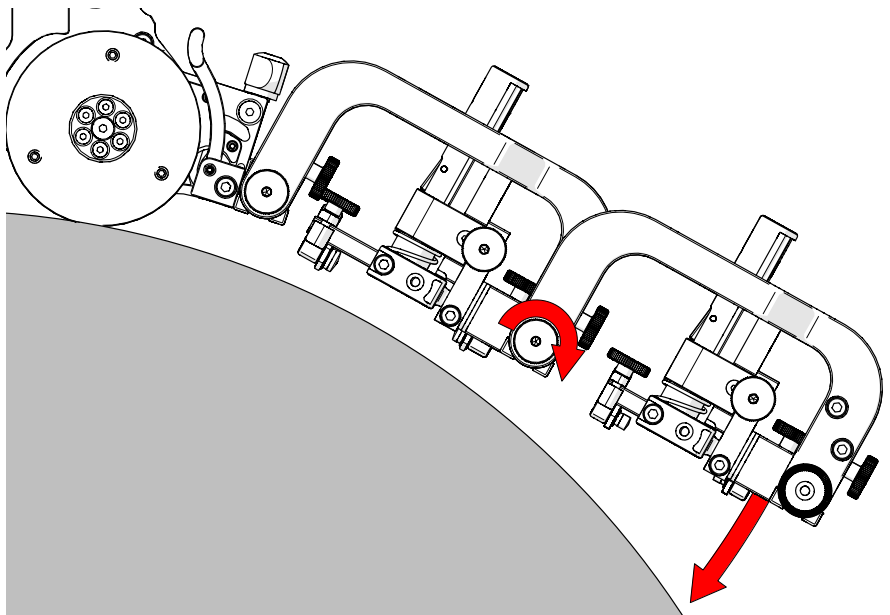

Fig. 147 - Set front rotational adjustment knob

6. Loosen the front rotational adjustment knob (*Fig. 147*) to align the TOFD probe holders parallel with the scan surface (*Fig. 148*).

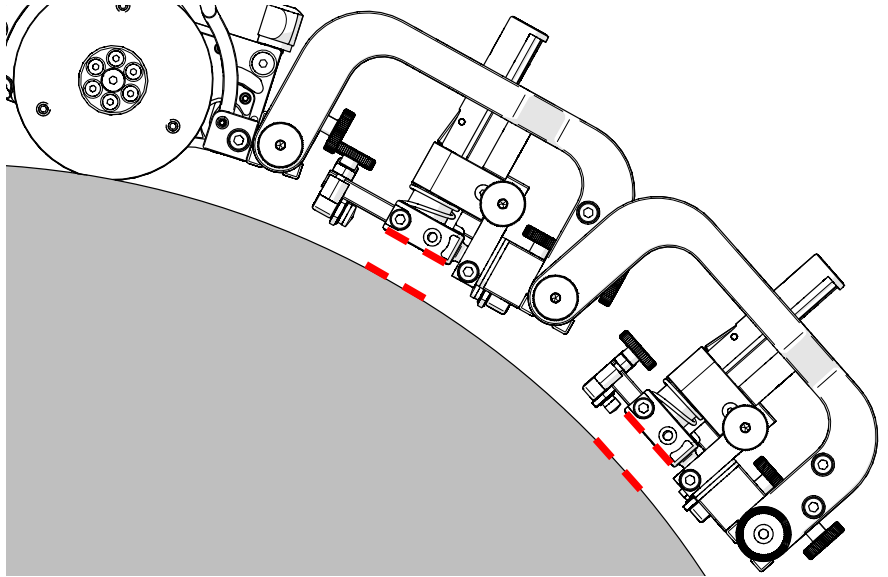

Fig. 148 - Align probes with the scan surface tangent

7. Lower probe holders to the inspection surface (see *Probe Holder Vertical Adjustment* on page 53 for additional details).

### 5.9.3. Pivoting Probe Holder Frame



#### **WARNING! FALLING OBJECT HAZARD.**

It is imperative that the steps below be followed to properly set the height of the probe holder frame. If the height of the probe holder frame is set too low, the crawler may fall and **SEVERE INJURY** or **DEATH** could result.

The pivoting probe holder frame utilizes vertical probe holders. The SKOOT HT can guide as many as 6 probes in the longitudinal direction.

**NOTE:** A minimum OD of 762 mm (30 in) is required for longitudinal scanning.

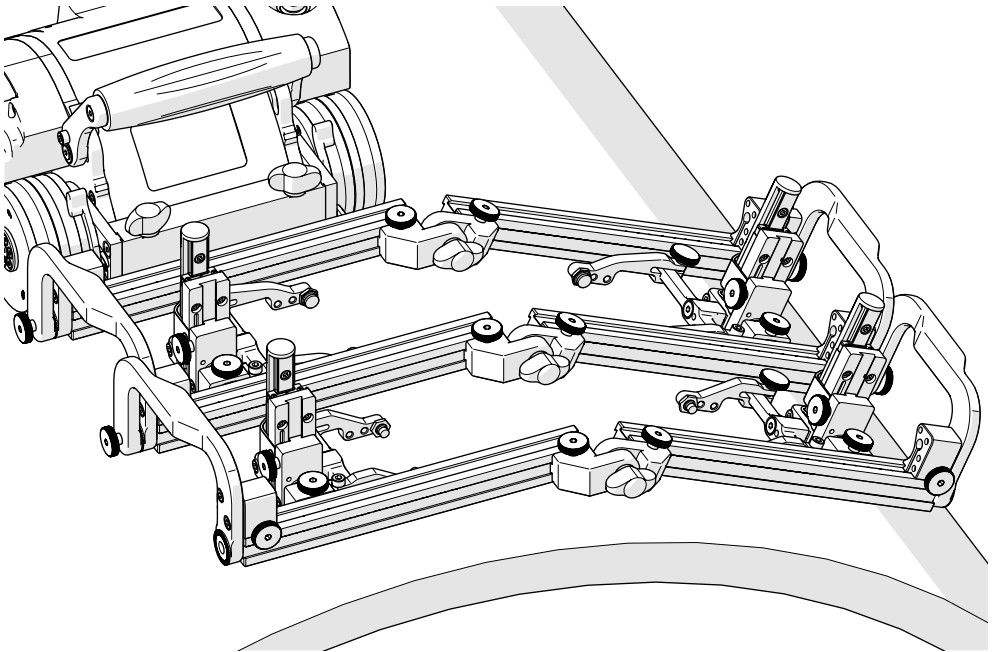

Fig. 149 - Pivoting Probe Holder Frame

### 5.9.3.1 Mounting a Pivoting Probe Holder Frame

1. If attached, use the 3 mm hex driver to remove the probe holder pivot mount from the pivoting probe holder frame.
2. Attach the wedges that are to be used with the probe holders (see *Probe Holder Setup* on page 52 for additional details).

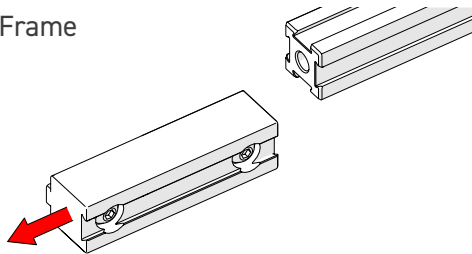

Fig. 150 - Remove probe holder pivot mount

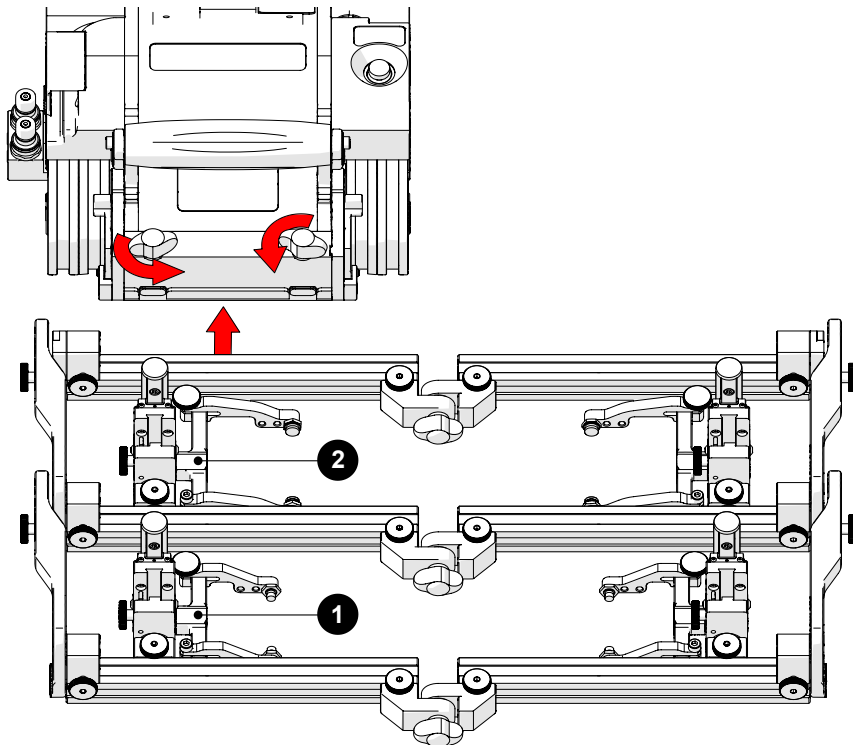

Fig. 151 - Connect frame to crawler's swivel mount

1. Affix the probe holders (with attached wedges) to the probe holder frame. Place the secondary probe holders at the front of the frame (Fig. 151-1) while placing the primary probe holders at the rear of the frame system (Fig. 151-2).

**TIP:** Phased array wedges are designed to be pulled along a scan surface.

2. Mount the pivoting probe holder frame to the crawler (see *Swivel Mount* on page 41 for additional details).

## 5.9.4. Pivoting Probe Holder Frame Setup - Longitudinal Scanning

### 5.9.4.1 Longitudinal Scanning

To prepare the pivoting probe holder frame for longitudinal scanning, follow these steps:

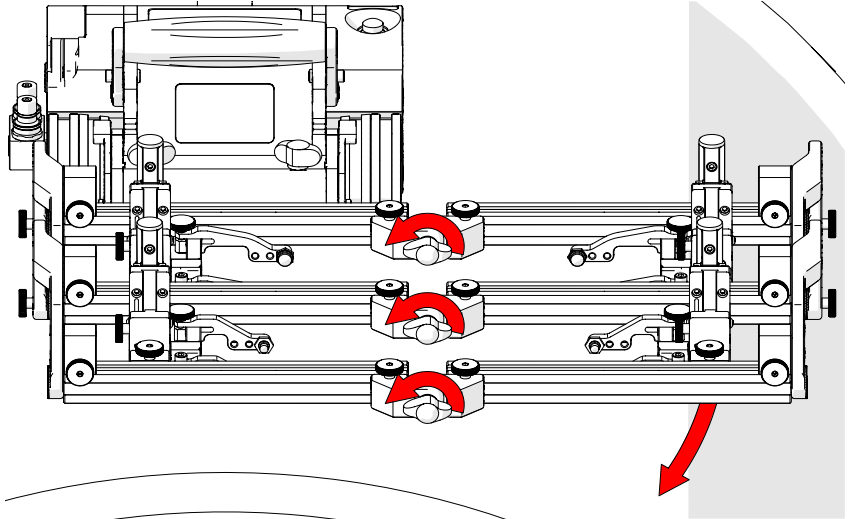

Fig. 152 - Loosen pivot wing knobs

**NOTE:** The swivel mount must be in a horizontal position during longitudinal scanning (see "Swivel Mount" on page 41).

1. Loosen the pivot wing knobs at the centre of the frame system (Fig. 152). Lower the left side of the frame system to align with the tangent of the scan surface. Tighten the pivot wing knobs.

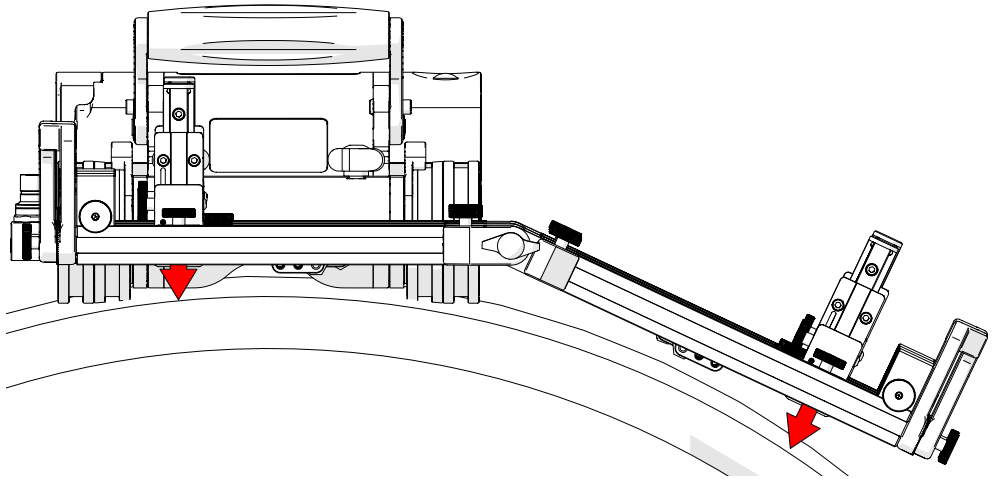

Fig. 153 - Tighten pivot wing knobs

2. Lower the vertical probe holders (see "Probe Holder Vertical Adjustment" on page 53).

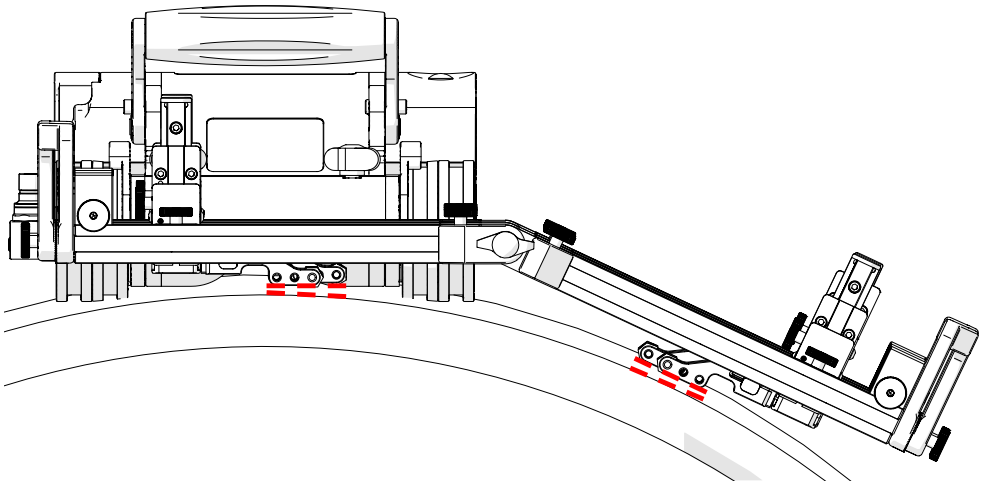

Fig. 154 - Correct probe holder longitudinal adjustment

3. Ensure probe holder arms are parallel to the scan surface (see "Probe Holder Longitudinal Adjustment" on page 55).

#### 5.9.4.2 Circumferential Scanning

(see *Vertical Probe Holder Frame - Flat or Circumferential Only* on page 68 for additional details)

### 5.9.4.3 Pivoting Probe Holder Frame - Flange Scanning

**NOTE:** The optical guide pivot mount is not compatible with the following configuration.

The pivoting probe holder frame may be configured to allow scanning of flanges and the like. The following steps explain setup of this configuration:

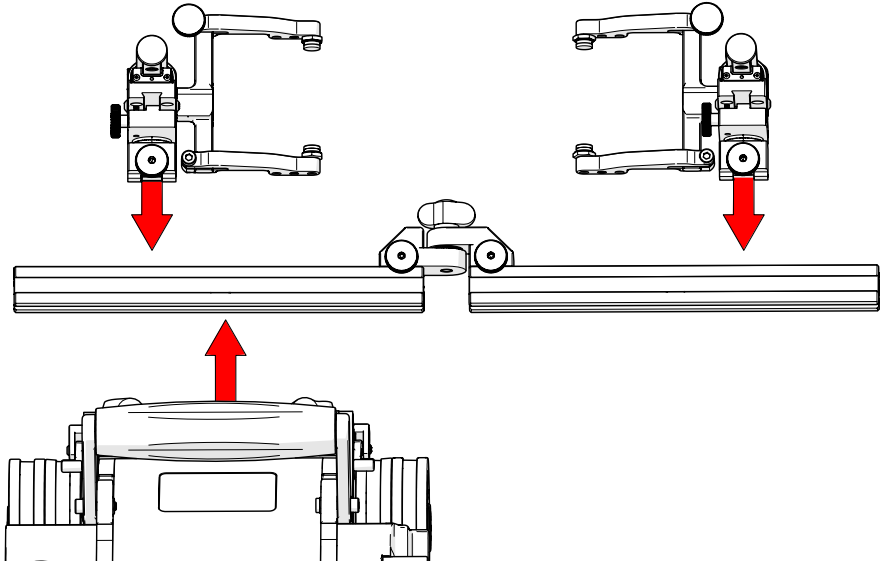

Fig. 155 - Configure assembly and mount to SKOOT HT

1. Disassemble the pivoting probe holder frame to achieve the setup shown (Fig. 155). Ensure proper placement of the frame bar with attached mounting point in relation to the SKOOT HT.

**TIP:** When the scanning surface is circumferential, only one frame bar with two probes can be used.

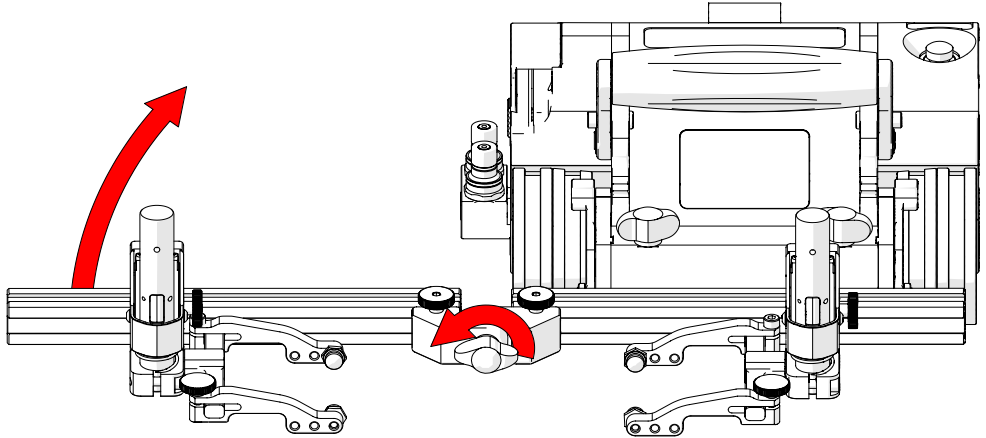

Fig. 156 - Lift frame bar to avoid interference

2. Loosen the pivot wing knob and raise the frame bar to an angle greater than the surface to be scanned (Fig. 156). Tighten the pivot wing knob and place crawler on scan surface (see "Placement of Crawler on Inspection Surface" on page 87)
3. Release the front swivel mount adjustment levers to align the swivel mount parallel to the scan surface (Fig. 157).

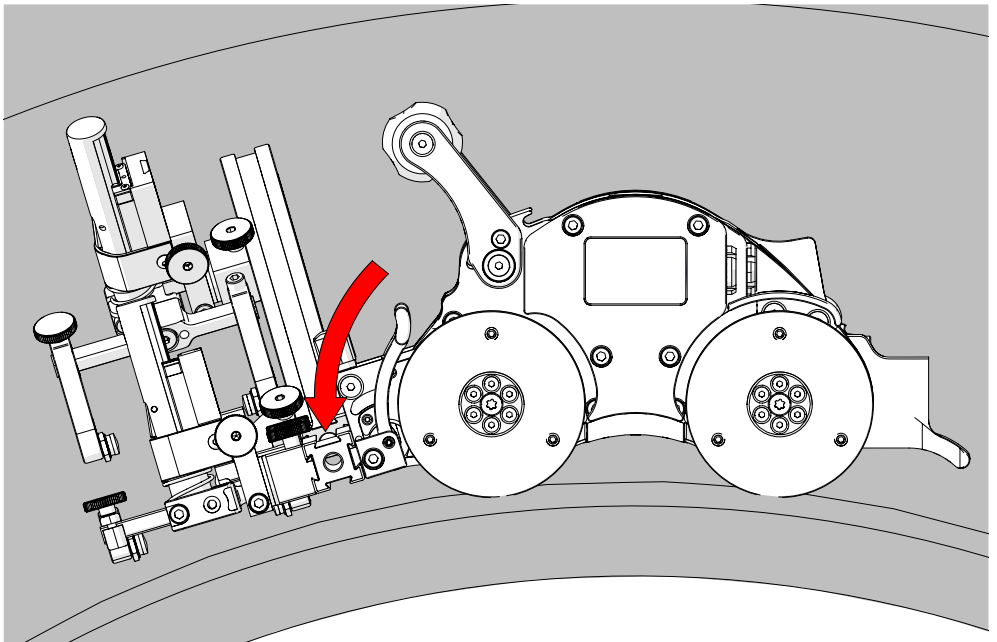

Fig. 157 - Align swivel mount with scan surface

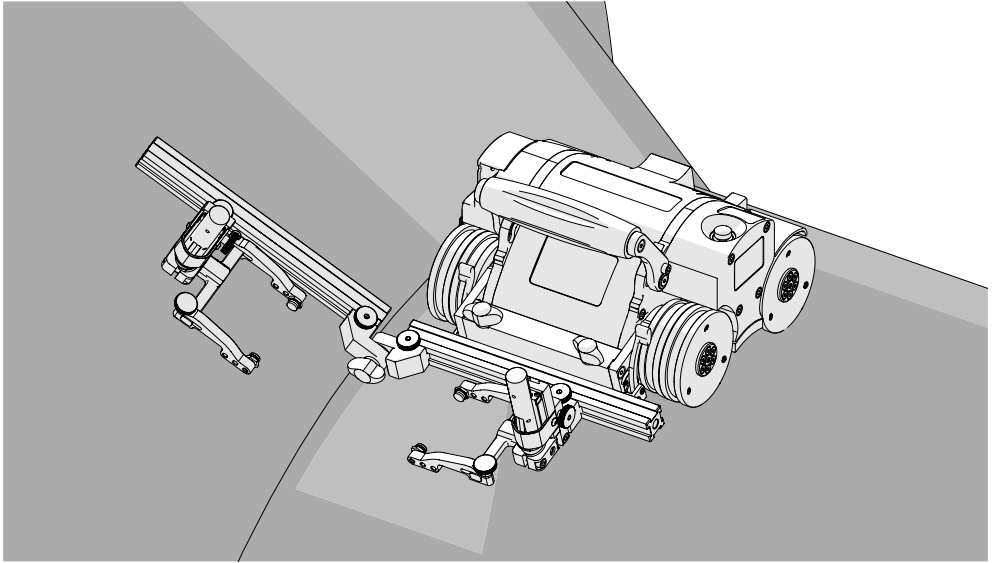

Fig. 158 - Align frame bar with flange scan surface

4. Loosen the pivot wing knob and align the frame bar parallel with the scan surface (*Fig. 158*).

## 5.9.5. Battery Powered Optical Guide Pivot Mount

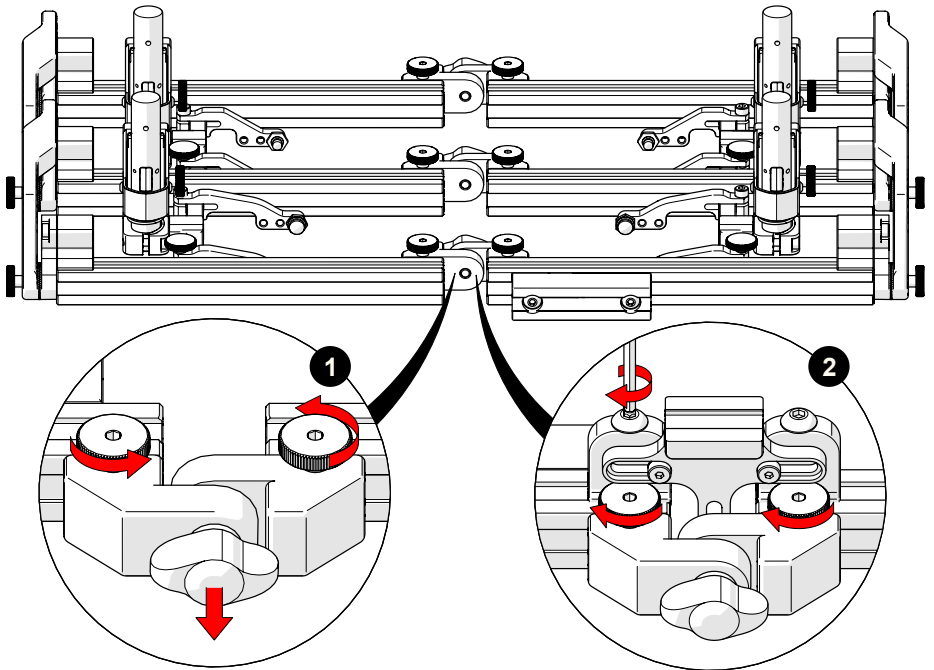

Fig. 159 - Battery powered optical guide pivot mount installation

An optional mounting point for any optical guide is available.

► (see "Battery Powered Optical Guide" on page 84)

To install the pivot mount, see these following instructions:

1. Remove the dovetail bar pivot from one of the sets of frame bars (Fig. 159-1). The choice of which dovetail bar pivot to remove is at the user's discretion.
2. Attach the optical guide pivot mount to the frame bars (Fig. 159-2), tighten the dovetail knobs and the dovetail screws. Ensure a flush alignment of the pivot mount and the frame bars to achieve proper centering of the optical guide pivot mount.
3. Mount an optical guide following instructions (see "Battery Powered Optical Guide" on page 84).

## 5.10. HT Cable and Hose Management

**NOTE:** Orient the sleeving to ensure the velcro is not against the hot surface.

The HT Cable and Hose Management is offered in a variety of lengths and provides a means of bundling and protecting cables and hoses that connect to the scanner.

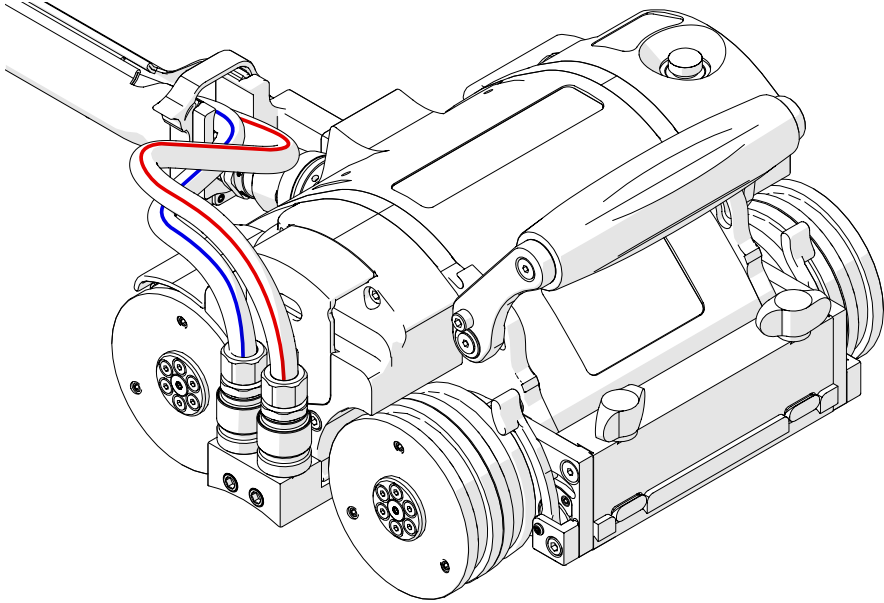

Fig. 160 - HT cable and hose management

### 5.10.1. Mounting the HT Cable Management

To attach HT cable management with threaded mount, follow these steps:

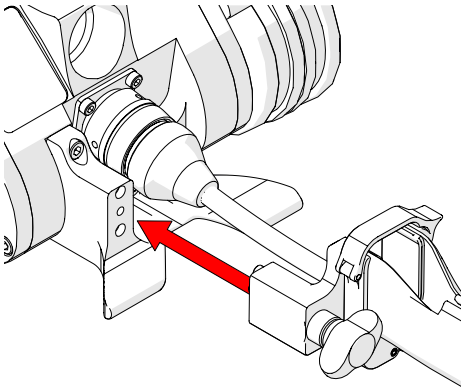

Fig. 161 - Align with umbilical

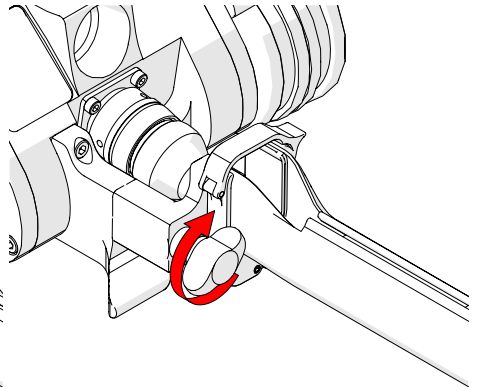

Fig. 162 - Tighten wing knob

1. Align the HT cable management clamp with the appropriate mounting position on the user umbilical breakout (Fig. 161).
2. Tighten the HT cable management clamp wing knob (Fig. 162).

### 5.10.2. Cable Management Setup

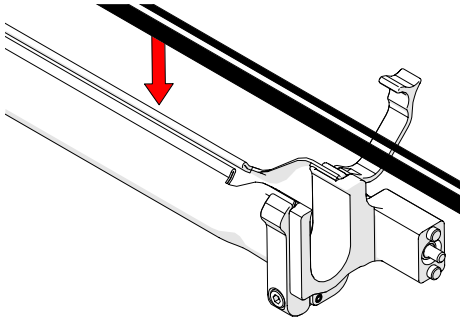

Fig. 163 - Insert cables and hoses

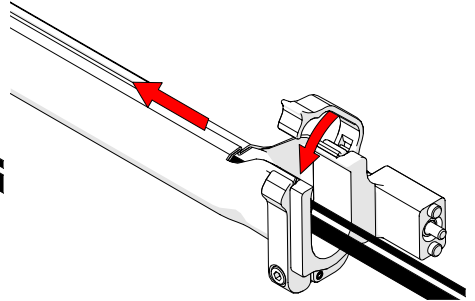

Fig. 164 - Close velcro

**NOTE:** Orient the sleeving to ensure the velcro is not against the hot surface.

1. Open the HT cable management sleeving. Begin at the clamp end and start placing the cabling in the sleeving (Fig. 163).
2. Follow the cable placement pressing the velcro of sleeving closed (Fig. 164).
3. When necessary, the cable management may be opened to allow any cables to be routed out of the sleeving.

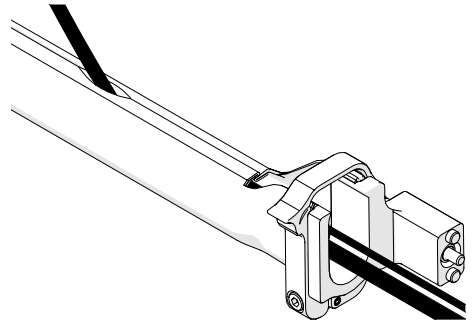

Fig. 165 - Flexible routing

### 5.10.3. Clamp Setup

In the event the sleeving becomes disconnected from the HT cable management clamp, follow these instructions to reattach the sleeving and clamp.

1. Loosen the clamp screw using the supplied 3 mm hex driver.
2. Slide the clamp around the sleeving first and then slide the sleeving around the outside of the HT cable management mount (Fig. 166).
3. Align the opening and the HT cable management clamp opening.
4. Slide the clamp over the tube and HT cable management mount pinching the tube in between (Fig. 167).
5. Tighten the clamp screw (Fig. 168).

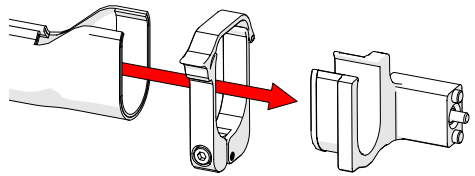

Fig. 166 - Slide tube around mount

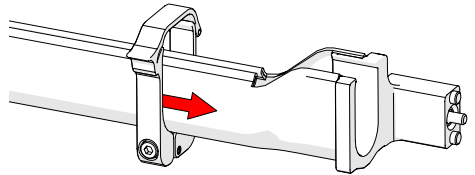

Fig. 167 - Slide clamp onto mount

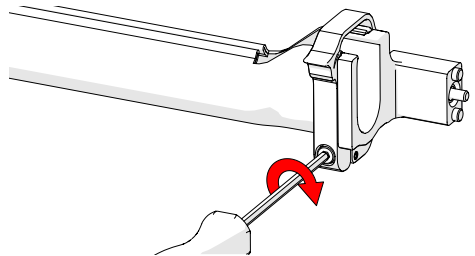

Fig. 168 - Tighten clamp screw

### 5.10.4. Hose Connection and Routing

The hoses carry coolant which dissipates heat in crawler and various components. The hoses **MUST** be routed through the HT cable management system.

The hoses are affixed with quick connects that do not drip or leak when connecting or disconnecting.

1. Press the hose fittings onto the quick connects of the crawler (see "Connect hoses to crawler" on page 82).

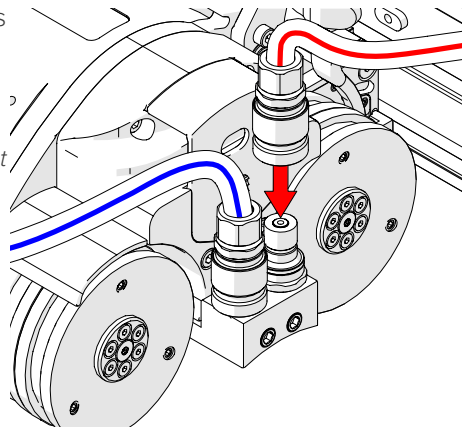

Fig. 169 - Connect hoses to crawler

2. Route the hoses through the HT cable management system and connect to the cooler (Fig. 170).

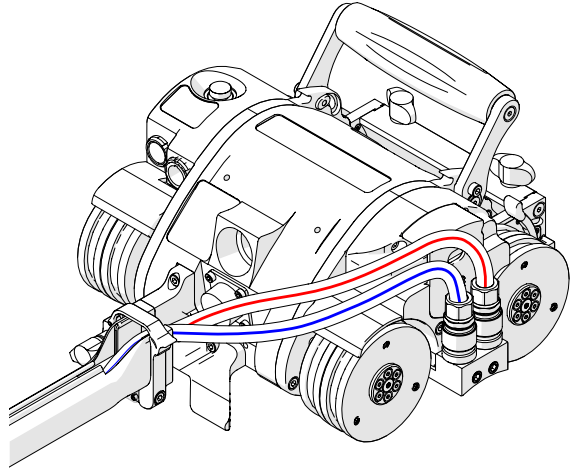

Fig. 170 - Hose routing to crawler

### 5.10.5. Disconnecting Hoses

1. To disconnect a hose, grasp the sleeve of the hose fitting and pull away from the crawler (Fig. 171).

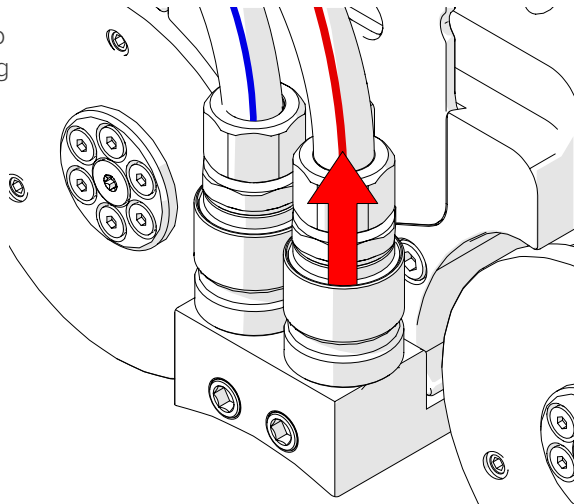

Fig. 171 - Disconnect hose by pulling sleeve of the quick connect

## 5.11. Accessories

### 5.11.1. Battery Powered Optical Guide



**WARNING! LASER RADIATION.** The battery powered optical guide contains a Class 1M laser. Do not view directly with optical instruments.

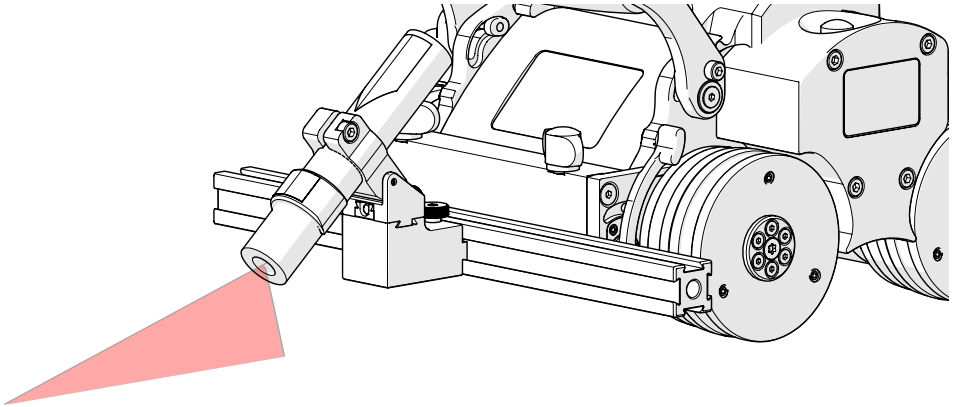

Fig. 172 - Battery powered optical guide

The battery powered optical guide provides a reference point useful for aligning the SKOOT HT to a given path (*i.e. a weld*).

1. Loosen the battery powered optical guide knob and mount the guide to the frame bar (*Fig. 173*).
2. Tighten the battery powered optical guide knob.
3. Adjust the guide's friction pivot to aim the guide as required (*Fig. 174*).
4. Loosen the guide knob to adjust the side-to-side position as required.
5. The included perpendicular mount allows for alternate mounting positions when required.

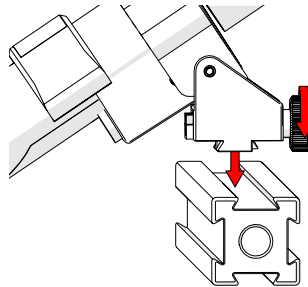

Fig. 173 - Mount on frame bar

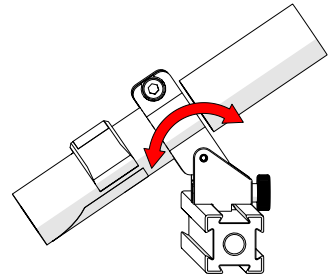

Fig. 174 - Aim guide

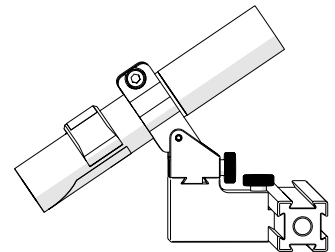

Fig. 175 - Perpendicular mount

**NOTE:** The battery powered optical guide requires 1 AA battery for operation.

## OPERATION

### 6.1. System Startup

To activate the system, follow these steps:

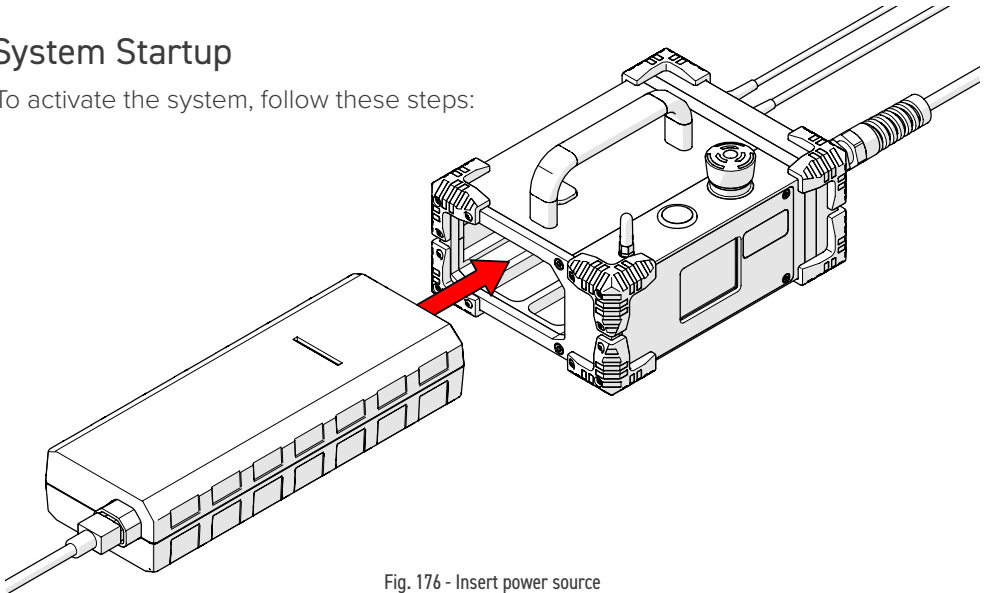

Fig. 176 - Insert power source

1. Insert power source into system controller dock (Fig. 176).
2. Connect the components (see "Configurations" on page 32).

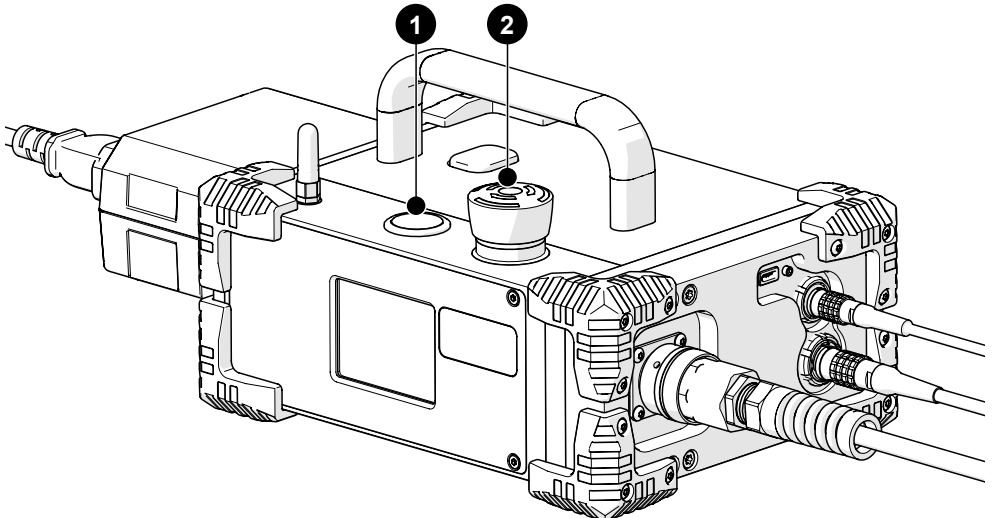

Fig. 177 - System controller

3. Locate the **2** red off push-button on the system controller. Rotate this button clockwise to unlatch (Fig. 177).
4. The **1** power button on the system controller activates the system (Fig. 177).

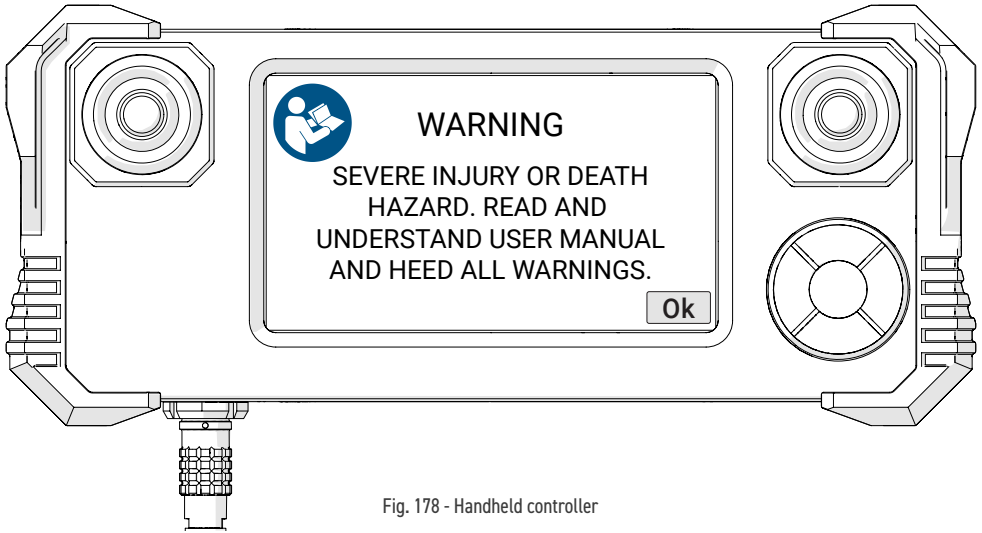

Fig. 178 - Handheld controller

5. A warning message will display on the handheld controller when power has been activated (Fig. 178). Once the dangers of using the SKOOT HT are recognized and understood by reading this user manual, touch **Ok** to acknowledge the warning.



Fig. 179 - Falling object warning

6. A second warning message (Fig. 179) will display requesting assurance that a No Entry Fall Zone has been established (see "No Entry Fall Zone" on page 28) and tether requirements are met (see "Tether Requirements and Attachment" on page 29). Acknowledge this warning by touching **Yes**.

7. Start the Cooler by referring to the separate Cooler user manual.

Once the system is initialized, the **Mode Select** screen will appear (see "Jog Mode" on page 94). The system is now ready for operation.

## 6.2. Placement of Crawler on Inspection Surface



**WARNING! HOT SURFACE.** The SKOOT HT crawler may reach temperatures that may cause burns if contacted with bare skin. Wear heat resistant safety gloves when handling.



**IMPORTANT!** It is important to place the crawler on the inspection surface as instructed below to protect the electronic components within the crawler from damaging shock. The crawler should never be slammed directly onto the surface.



**CAUTION!** Do **NOT** handle crawler using the umbilical cable. Use the provided handles.



**WARNING! MAGNETIC MATERIAL.** The wheels of the crawler produce an extremely strong magnetic field which may cause failure or permanent damage to items such as watches, memory devices, CRT monitors, medical devices or other electronics.

Tools, magnets and metal objects can cut, pinch or entrap hands and fingers. **HANDLE WITH CARE.**

People with pacemakers or ICD's must stay at least 25 cm (10 in) away.



**CAUTION!** Ensure Cooler is properly connected and pumping coolant through the SKOOT HT system before placing the crawler on a hot surface, and remains pumping until after the crawler is removed from the hot surface. Failure to do so could result in rupture of the tubes due to overheating.

To place the crawler on the inspection surface, follow these steps:

1. Ensure crawler preparation is complete (see "Preparation for Use" on page 28) and system startup has been performed (see "System Startup" on page 85).

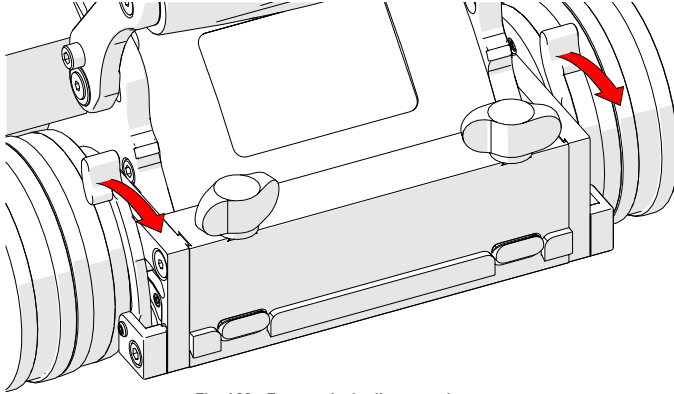

Fig. 180 - Front swivel adjustment levers

2. Release the front swivel adjustment levers (Fig. 180), located at the front of the crawler, to position the front swivel mount.
3. Raise the front swivel mount to ensure they will not hinder the wheels from contacting the inspection surface (see "Swivel Mount" on page 41).

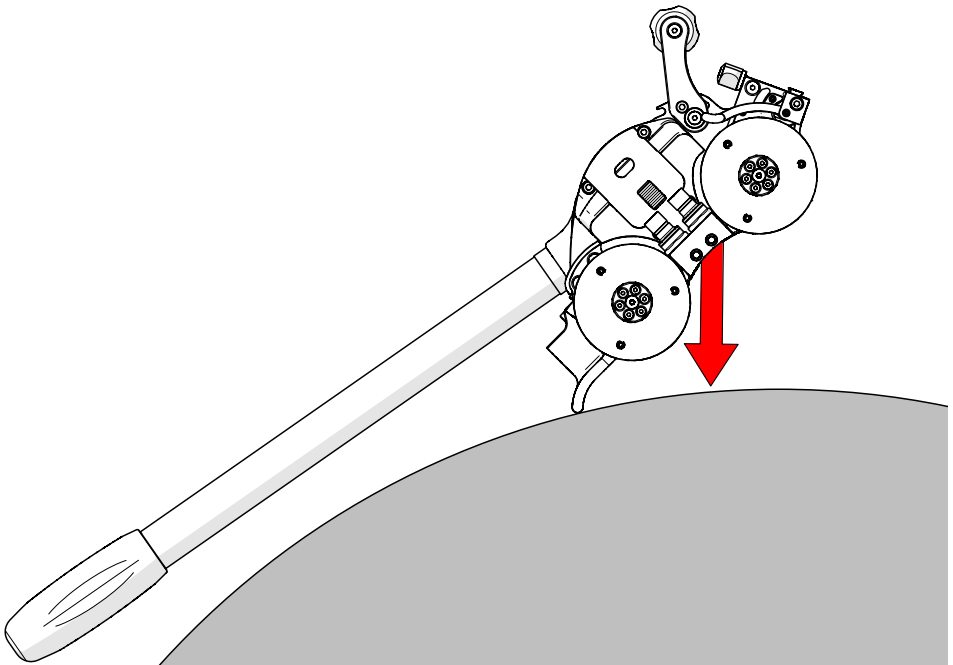

Fig. 181 - Lower crawler's pry point towards inspection surface

**NOTE:** Umbilical, accessories and hoses not included in illustration.

4. Ensure the manipulation handle is installed on the crawler.
5. Ensure the Cooler is running and pumping fluid to the crawler. Do NOT place a crawler on a heated surface unless the Cooler is running properly.
6. While firmly grasping the crawler handle with one hand, and the manipulation handle with the other, carefully lower the pry point of the crawler towards the inspection surface with the wheels of the crawler held as high off the surface as possible (*Fig. 181*).

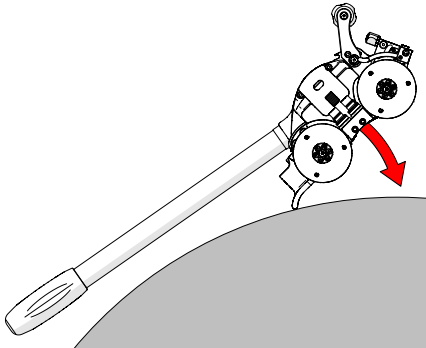

Fig. 182 - Pivot on pry point towards scan surface

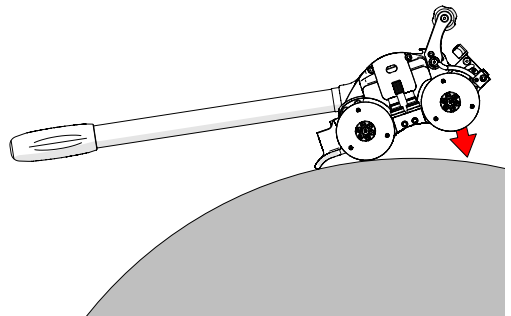

Fig. 183 - Lower scanner as gently as possible

7. With a firm grip on the manipulation handle, slowly lower the wheels of the crawler (*Fig. 182*) towards the inspection surface until all four wheels contact the surface.

### 6.3. Removal of Crawler from Inspection Surface



**WARNING! HOT SURFACE.** The SKOOT HT crawler may reach temperatures that may cause burns if contacted with bare skin. Wear heat resistant safety gloves when handling.



**IMPORTANT!** It is important to place the crawler on the inspection surface as instructed below to protect the electronic components within the crawler from damaging shock. The crawler should never be slammed directly onto the surface.



**CAUTION!** Do **NOT** handle crawler using the umbilical cable. Use the provided handles.



**WARNING! MAGNETIC MATERIAL.** The wheels of the crawler produce an extremely strong magnetic field which may cause failure or permanent damage to items such as watches, memory devices, CRT monitors, medical devices or other electronics.

Tools, magnets and metal objects can cut, pinch or entrap hands and fingers. **HANDLE WITH CARE.**

People with pacemakers or ICD's must stay at least 25 cm (10 in) away.

To remove the crawler on the inspection surface, follow these steps:

**NOTE:** Umbilical, accessories and hoses not included in illustration.

1. Ensure the manipulation handle is installed on the crawler.

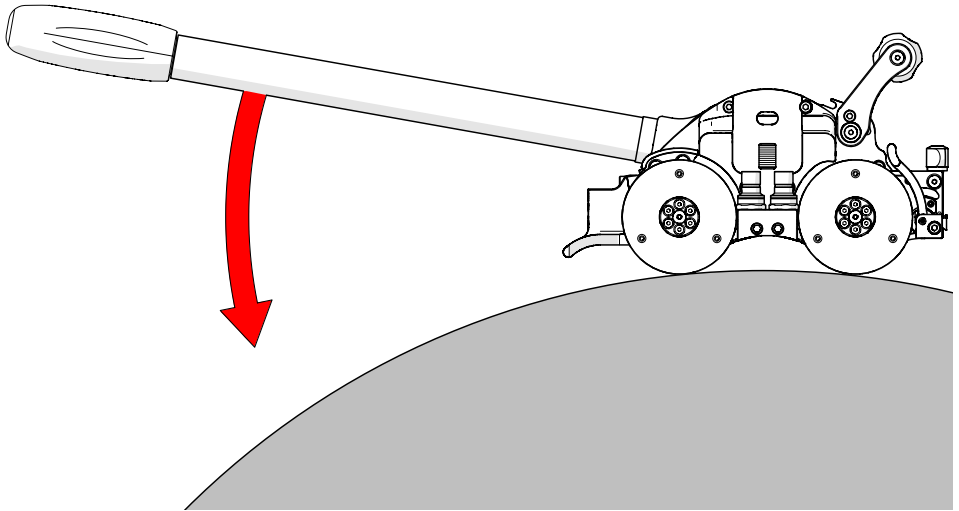

Fig. 184 - Press down on manipulation handle

2. Firmly grasp the crawler handle with one hand, and the manipulation handle with the other, carefully press down on the manipulation handle to lower the pry point of the crawler towards the inspection surface (*Fig. 184*).

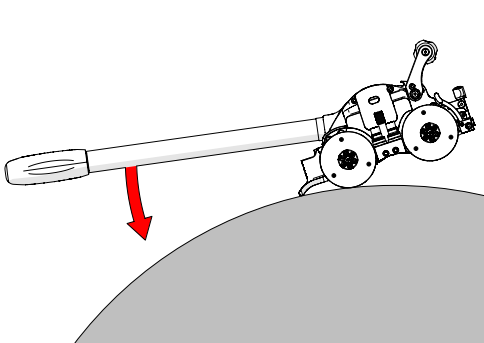

Fig. 185 - Pivot away from scan surface using pry point

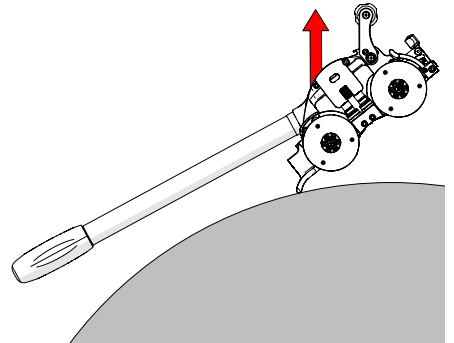

Fig. 186 - Lift from scan surface

3. When the front two wheels of the crawler separate from the scan surface, continue to press down on the manipulation handle (*Fig. 185*).
4. Pivot the crawler away from the scan surface and lift the crawler using the manipulation handle and the crawler handle (*Fig. 186*).

## 6.4. Operation

### 6.4.1. Handheld Controller Layout

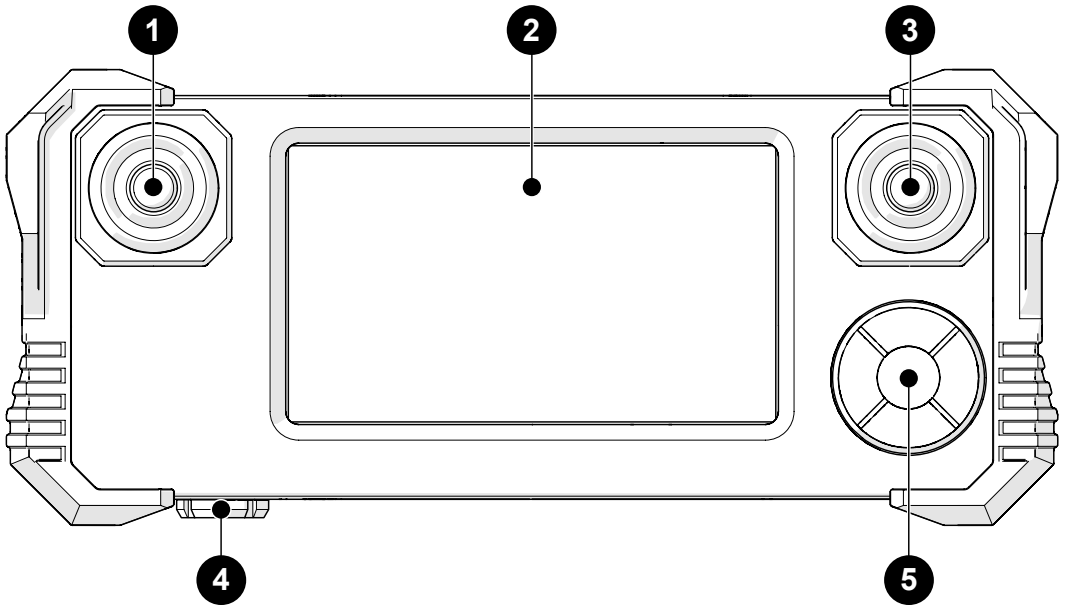

Fig. 187 - Handheld Controller

|          |                            |   |
|----------|----------------------------|---|
| <b>1</b> | Raster joystick            | (see "Joysticks" on page 93)  |
| <b>2</b> | Touchscreen                | (see "Touchscreen" on page 93)  |
| <b>3</b> | Fwd/Rev joystick           | (see "Joysticks" on page 93)  |
| <b>4</b> | Controller cable connector | Connection point for the auxiliary cable.                             |
| <b>5</b> | D-pad                      | A means of navigating the on screen menus of the handheld controller. |

### 6.4.1.1 Touchscreen

The **2** handheld controller touchscreen is the primary operator interface for the system. Buttons are indicated on-screen with a red border (*Fig. 187*).

### 6.4.1.2 D-pad

The **5** D-pad provides a redundant system control that may be utilized as an alternative to the touchscreen. A blinking box around a button indicates the D-pad selection. Pressing the outer buttons of the D-pad selects different buttons on-screen. Press the centre button of the D-pad to choose the button currently selected (*Fig. 187*).

### 6.4.1.3 Joysticks

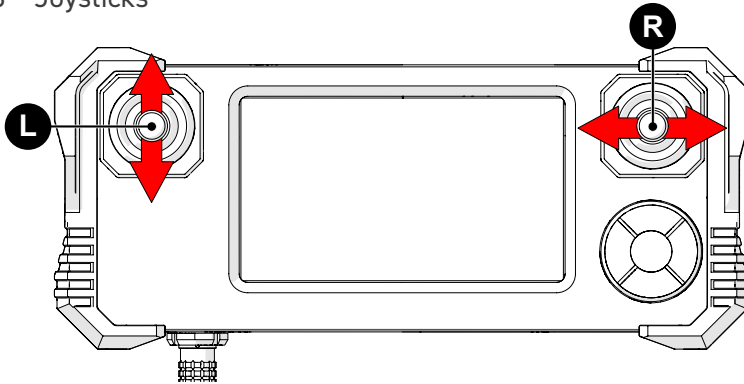

Fig. 188 - Handheld controller joysticks

The joysticks control system motion. The **L** left joystick controls the forward/reverse movement of the crawler. The **R** right joystick controls Raster Arm HT movement (*Fig. 188*).

## 6.4.2. Mode Select Screen

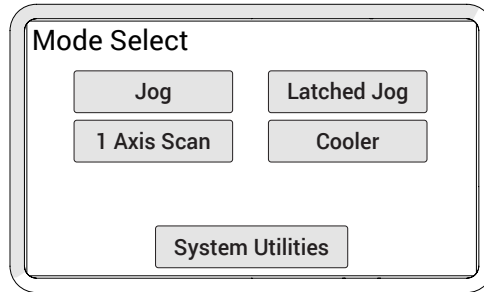

Fig. 189 - Mode select

The **Mode Select** screen offers four modes of operation for the system:

|                  |   |
|------------------|---|
| Jog Mode         | (see "Jog Mode" on page 94)                 |
| Latched Jog Mode | (see "Latched Jog Mode" on page 96)         |
| 1 Axis Scan Mode | (see "1 Axis Scan Mode" on page 97)         |
| Cooler           | (see "Cooler Mode" on page 100)             |
| System Utilities | (see "System Utilities Screen" on page 103) |

## 6.4.3. Jog Mode

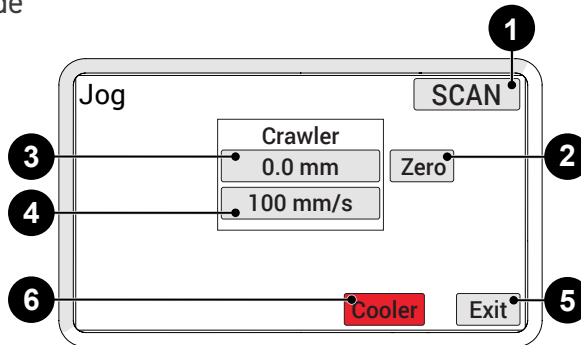

Fig. 190 - Button identification

Jog mode manually controls the system movement using the joysticks.

- 1** Scan/Rapid Button  
(Fig. 190)

Used to quickly switch between crawler speeds. The speed in either mode can be manually set to the users preference.

***TIP:** Fine adjustments of speed can be made in the User Settings (see "User Settings Screen" on page 103).*
- 2** Zero Button

Sets the current position to zero for all modules.
- 3** Module Position Button(s)

Displays the current position of the crawler and the Raster Arm HT. Press to set the position to any value using the **Edit** screen. When a module position is modified, the position will be modified for all other system modes.

***NOTE:** This function only zeroes the number displayed on the SKOOT HT handheld controller. It does not zero the position used in the data acquisition instrument.*
- 4** Module Rate Button(s)

Displays the current maximum rate for the selected speed mode. Press to set the maximum rate using the **Edit** screen. The movement commanded by the joysticks will be limited to the indicated rate. When a rate is modified, the rate will be modified for all other system modes.
- 5** Exit Button

Exits the jog mode and returns to the **Mode Select** screen.
- 6** Cooler Button

Press to access the cooler controls. The cooler button will blink rapidly to indicate that the cooler is deactivated and not pumping coolant to the scanner.

#### 6.4.4. Latched Jog Mode

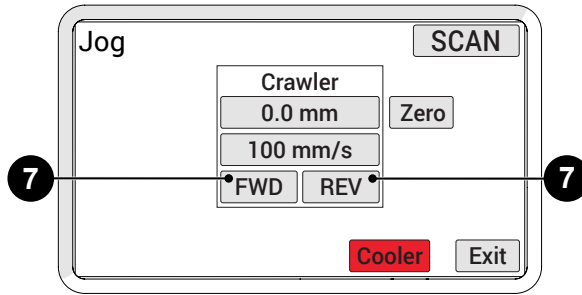

Fig. 191 - Latched jog mode

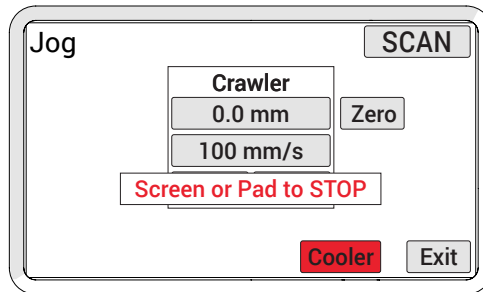

Fig. 192 - Latched jog stop screen

Identical to standard jog mode, latched jog mode adds forward or reverse crawler movement at the selected scan rate. This eliminates the need to manually hold the left joystick (see "Jog Mode" on page 94).

#### 7 FWD & REV Buttons:

The **FWD** and **REV** buttons are located in the crawler tab. Press the **FWD** or **REV** button to drive the crawler at the current maximum scan rate. Touching the handheld controller screen or pressing the D-pad stops crawler movement.

**NOTE:** The **FWD** & **REV** Buttons will not be present in rapid mode.

### 6.4.5. 1 Axis Scan Mode

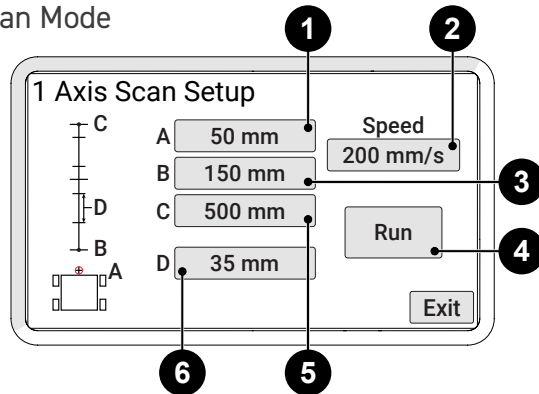

Fig. 193 - 1 Axis scan mode

1 Axis Scan mode drives the crawler in a straight line, stopping at programmed intervals.

|   |              |  |
|---|--------------|--|
| 1 | Point A      | The current encoder position of the crawler.   |
| 2 | Speed Button | Access the <b>User Settings</b> screen to set the crawler's scan speed.  |
| 3 | Point B      | The start point of the scan travel. The system will move the scanner from the <b>A</b> point to this point at the start of a scan. |
| 4 | Run Button   | Enables the <b>1 Axis Scan</b> screen (see "1 Axis Scan Screen" on page 98).   |
| 5 | Point C      | The finish point of the overall scan travel.   |
| 6 | Setting D    | The distance the system will advance.  |

The **1 Axis Scan Setup** screen indicates the scan functions that may be entered. Each point and setting, **A, B, C, D**, corresponds to a coordinate entry button on the screen.

A typical scan begins at the **A** position and moves to the **B** position. Scanning begins at the **B** position and scans the distance of **D** until the **C** position is reached.

### 6.4.5.1 1 Axis Scan Screen

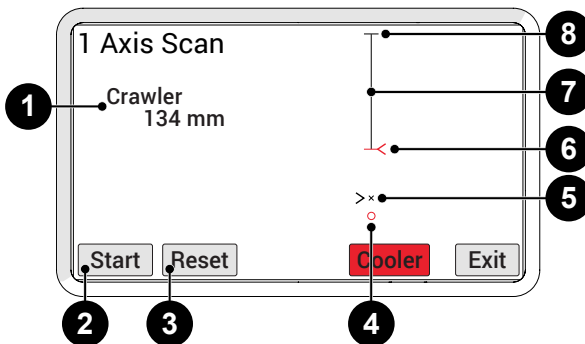

Fig. 194 - 1 Axis scan screen

The **1 Axis Scan** screen initiates and monitors scan, and advances the set distance. The initial scan screen is an approximation of a full view (*zoomed out*) of the entire scan path.

|  |   |
|--|---|
| <p><b>1</b> Crawler (Motor)<br/>(Fig. 194)</p> | <p>The current encoder position of the crawler. If an idler encoder is available, it will also indicate the encoder selected (Motor or Idler) for crawler positioning as set in the User Settings (see "User Settings Screen" on page 103).</p> |
| <p><b>2</b> Start/Stop button</p>              | <p>Start or stop the scan sequence. When a scan has been stopped while in progress, the start button resumes the scan.</p>  |
| <p><b>3</b> Reset</p>                          | <p>Return the scanner to the <b>A</b> position. Press the start button to begin the scan sequence from the initial setting.</p>   |
| <p><b>4</b> Scan location</p>                  | <p>Small red circle indicates the <b>A</b> position.</p>  |
| <p><b>5</b> Scanner position</p>               | <p>The blinking cross hair indicates the current scanner position.</p>  |
| <p><b>6</b> Next scanner position</p>          | <p>Where the scanner will travel to next.</p> <p><b>NOTE:</b> The red indicator is always where the scanner will go next.</p>   |
| <p><b>7</b> Summary screen</p>                 | <p>A visual representation of the scan area.</p>  |
| <p><b>8</b> End position</p>                   | <p>The completed distance of programmed travel.</p>   |

When Start is pressed the first time, the scanner will travel to point **B** and pause. The summary screen shows a closer view (*zoom in*) of the scan path.

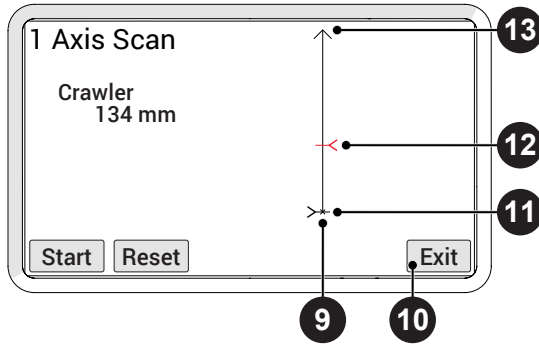

Fig. 195 - 1 Axis scan screen

- |   |   |
|---|---|
| <p><b>9</b> Scanner location</p> <p><b>10</b> Exit button</p> | <p>The current encoder position of the crawler.</p> <p>Pressing <b>Exit</b> stops all scanning motion. When the scanner is not in the <b>A</b> position a warning appears (Fig. 196). The warning alerts that the <b>A</b> position of the scanner will be changed to the current position.</p> |
|---|---|

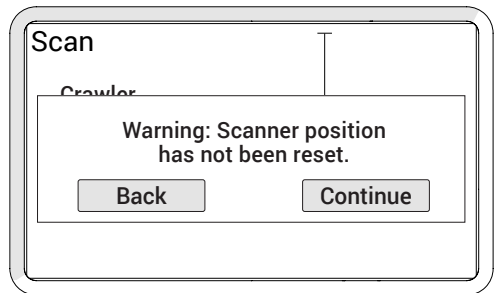

Fig. 196 - Exit warning

Press **Back** to return to the **1 Axis Scan** screen to reset scanner and maintain original **A** position. Press **Continue** to exit to **1 Axis Scan Setup** screen.

- |   |  |
|---|--|
| <p><b>11</b> Scanner position</p> <p><b>12</b> Next scanner position</p> <p><b>13</b> End point</p> | <p>The blinking cross hair indicates the scanner position.</p> <p>When the scanner will travel to next.</p> <p>Arrow indicates the travel will continue to advance, Straight line indicates end of programed travel.</p> |
|---|--|

### 6.4.6. Cooler Mode

For complete instructions (see "Cooler" user manual for additional details and instructions).

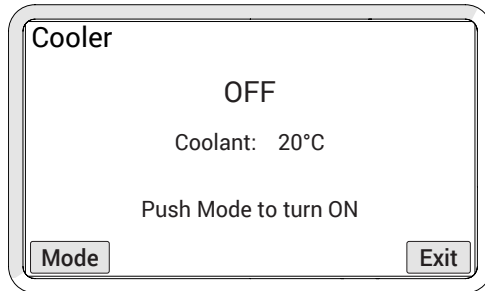

Fig. 197 - Standby screen

The **Cooler** screen controls cooler operation (Fig. 197). The **Mode** button operates as a toggle to activate, deactivate the cooler. The **Exit** button navigates to the previous screen.

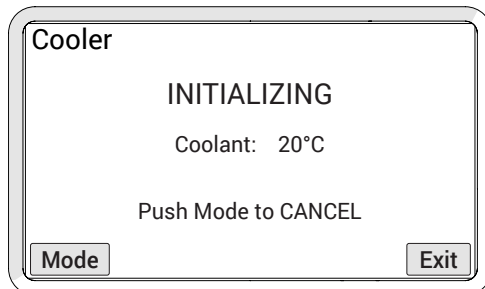

Fig. 198 - Initializing screen

Press the **Mode** button to activate the cooler. The **Initializing** screen appears (Fig. 198).

**NOTE:** Initializing will time-out if closed-loop flow is not fully established after 3 minutes.

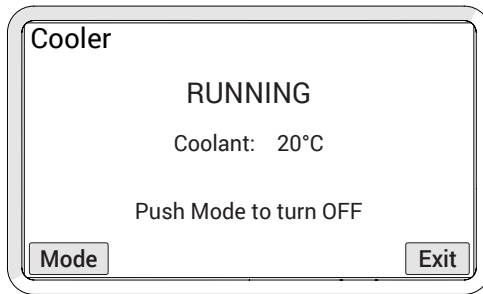

Fig. 199 - Running screen

Normal Cooler operation begins when the operating flow is achieved. The **Running** screen is displayed (Fig. 199).

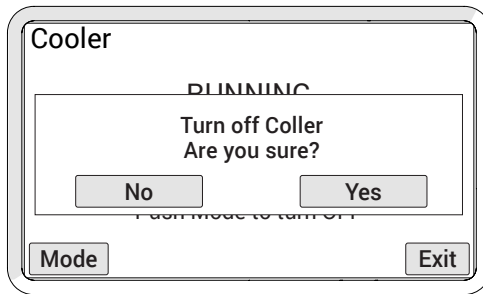

Fig. 200 - Running screen

While the Cooler is performing normal operation, pressing the **Mode** button displays a confirmation screen for Cooler shutdown (Fig. 200). If the **Yes** is not pressed within a 5 second period, normal Cooler operation continues and the **Running** screen appears.

**NOTE:** During shutdown confirmation, the system continues to operate normally until the YES button is pressed.

## 6.4.7. Cooler Warnings

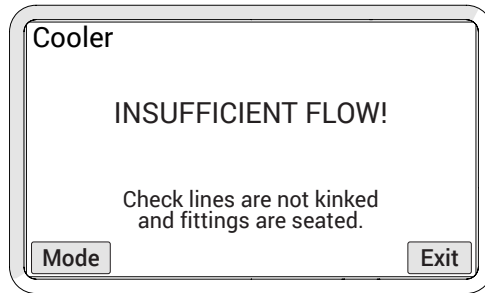

Fig. 201 - Warning screen

If warning appears during initialization (*Fig. 201*):

- ▶ Pump will turn off.
- ▶ User to ensure hoses are straight, unobstructed and contains no kinks or awkward bends.
- ▶ Press the **Mode** button to restart the Cooler.

If warning appears while the Cooler is running (*Fig. 201*):

- ▶ Pump will remain on.
- ▶ If hoses can not be quickly adjusted to remove warning, remove device relying on Cooler from any hot surface.

## 6.4.8. System Utilities Screen

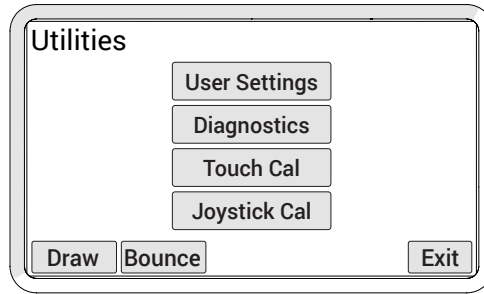

Fig. 202 - Utilities screen

The **Utilities** screen provides access to the setup, diagnostics and user preference settings.

|                                    |  |
|------------------------------------|--|
| User Settings Button<br>(Fig. 202) | Access the <b>User Settings</b> screen allowing for various user preferences to be adjusted. |
| Diagnostics Button                 | Enters the Diagnostic screens to monitor system components and function.                     |
| Touch Cal Button                   | Used to initiate the Touch Calibration screen.   |
| Joystick Cal Button                | Used to enter the Joystick Calibration screen.   |
| Draw Button                        | Enters mode used to test the touch screen accuracy and response.                             |

### 6.4.8.1 User Settings Screen

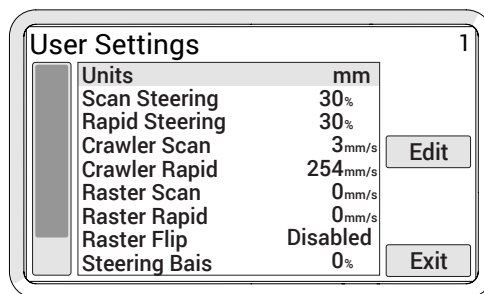

Fig. 203 - User settings screen

Allows user to customize the system to their preferences.

Use the touch screen or D-pad to select different settings.

Press **Edit** to enter the **Edit** screen to apply changes to the selected setting.

| Title              | Description  |
|--------------------|--|
| Units              | Changes the measurement units for display and user entry. When set to 0, units measure in inches. When set to 1, units measure in millimetres. |
| Crawler Scan       | Sets the crawler scan rate in the current units/second. This setting can also be changed through the Jog or Two Axis Scan Speed screens.       |
| Crawler Rapid      | Sets the crawler rapid rate in the current units/second. This setting may also be changed within other modes.                                  |
| Display Brightness | Sets the brightness of the display.  |

### 6.4.8.2 Diagnostics Screens

Several diagnostic screens allow various system functions to be monitored. Navigate to different diagnostic screens using the **PREV** and **NEXT** buttons. The **Exit** button returns to the **System Utilities** screen.

**NOTE:** *The diagnostic information requires an in depth understanding of the underlying technologies and programming in the system. Not all functions and information is explained in this manual.*

### 6.4.8.3 Touch Calibration Screen



Fig. 204 - Touch calibration screen

This option allows calibration of the touch screen. Typically, this should not be necessary.

Touch the screen as the markers appear in the four corners of the screen.

**TIP:** It is recommended that the markers be touched with a small object to enhance the touch position accuracy during calibration.

The new calibration is stored immediately when the fourth marker is pressed. The calibration utility exits and return to the **System Utilities** screen. To abort the calibration, the system power may be turned off before the last marker is pressed.

### 6.4.8.4 Joystick Calibration Screen

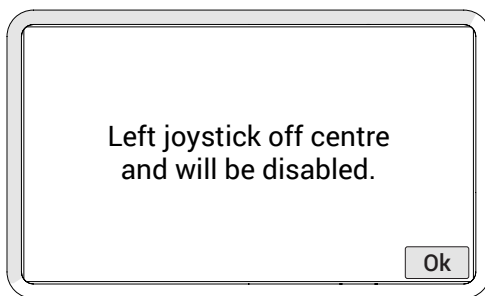

Fig. 205 - Joystick error

Typically joystick calibration is only necessary when a joystick off center error is detected upon startup (Fig. 205). Calibration may also be used when a joystick function does not appear to be properly centred.

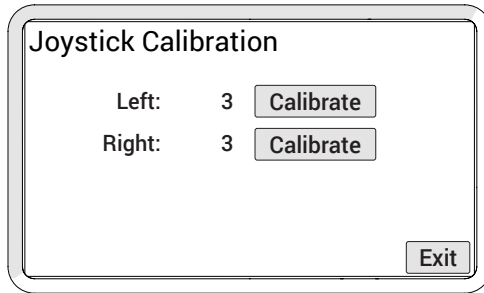

Fig. 206 - Joystick calibration screen

Current readings of the joysticks are displayed on the **Joystick Calibration** screen (Fig. 206). When the numbers are not near zero, press the **Calibrate** button to recalibrate to 0. The new calibration is stored when the **Exit** button is pressed.

#### 6.4.8.5 Draw

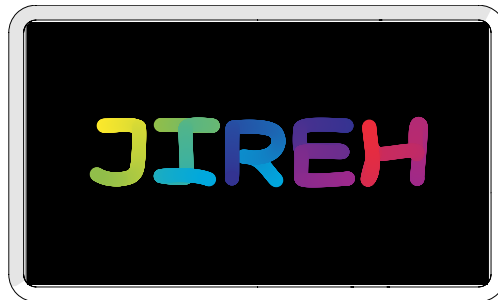

Fig. 207 - Draw utility

The draw utility may be used to test the function of the touchscreen. Exit the utility by pressing the D-pad.

## 6.4.9. High Internal Temperature Screen



**CAUTION! HOT SURFACE.** The handles of the crawler and crawler body may be hot to the touch. Use appropriate protective equipment when removing a crawler from a high temperature surface.

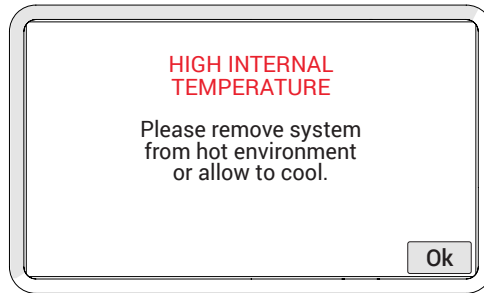

Fig. 208 - High internal temperature screen

When the system approaches its maximum operating temperature, the high internal temperature screen will display. When this alert screen is displayed, all motor and system function will cease.

Press **OK** to reactivate the system to remove **SKOOT HT** from the scan surface.

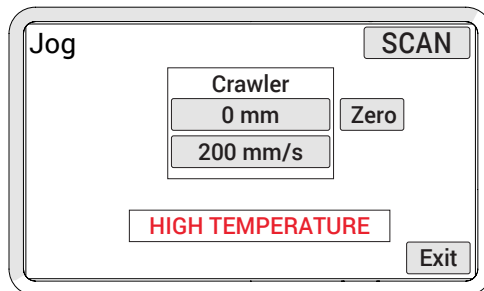

Fig. 209 - High internal temperature screen

Should the user choose to continue operating the crawler, the **HIGH TEMPERATURE** warning will continue to display until the temperature falls below the set temperature limit.

## MAINTENANCE

### 7.1. Safety Precautions Before Maintenance



#### **WARNING! ELECTRICAL SHOCK**

**HAZARD.** Disconnect the system controller when servicing the equipment. The system controller is powered even when the off push-button is latched in the off position.



#### **WARNING! MAGNETIC MATERIAL.**

The wheels of the crawler produce an extremely strong magnetic field which may cause failure or permanent damage to items such as watches, memory devices, CRT monitors, medical devices or other electronics.



Tools, magnets and metal objects can cut, pinch or entrap hands and fingers. **HANDLE WITH CARE.**

Those with pacemakers or ICD's must stay at least 25 cm (10 in) away at all times.

### 7.2. Cleaning

General cleaning of all components is important to keep the system working properly. All components that do not have wiring or cables are completely waterproof. Components can be washed with warm water, dish soap and a medium bristle brush. Before using the scanner ensure that all connectors are free of water and moisture.

**TIP:** All components with wiring, cables or electrical connections are splashproof but not submersible.

**NOTE:** Never use strong solvents or abrasive materials to clean your scanner components.

### 7.3. Maintenance Schedule

The SKOOT HT system must be maintained according to the following schedule:

| Task   | Frequency |
|--|-----------|
| <b><u>Inspect safety apparatus</u></b><br>This includes: <ul style="list-style-type: none"><li>▶ All components of tether system. Replace damaged components as necessary.</li></ul>   | Every Use |
| <b><u>Clean the drive wheels</u></b><br>Debris will collect on the magnetic wheels. Remove this debris before every use. An effective cleaning method uses adhesive-backed tape ( <i>e.g. duct tape</i> ) to 'pull' the debris off the wheels.   | Every Use |
| <b><u>Inspect cables and connectors</u></b><br>Inspect the umbilical cable, the control cable and the system controller cable for damage. Have any damaged cable repaired by a qualified person or replace the cable assembly as necessary.<br>Inspect all connectors for damage or moisture. Straighten bent pins. Dry connectors before using. | Every Use |
| <b><u>General cleaning</u></b><br>Ensure that the scanner stays relatively clean by wiping off any excess dirt or other contaminants after every use.  | Every Use |

## TROUBLESHOOTING

### 8.1. Startup Issues

Two messages are possible in the event of a startup issue: **Joystick Off Center** or **Checking Network**.

#### 8.1.1. Joystick Off Center

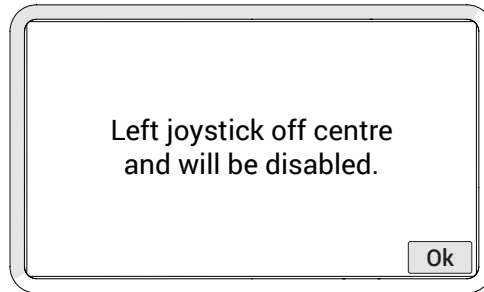

Fig. 210 - Joystick off centre screen

Upon system startup, the joystick positions are detected. When a joystick is detected outside the centre position, the **Joystick Off Center** screen displays indicating the joystick will be disabled. Press **Ok** to continue system startup. All system functions will work normally with the exception of movements that require joystick operation.

Ensure the handheld controller's joysticks are free of interference and reset the system power to enable joystick control.

If no interference of the joystick is present, the joystick calibration may need to be performed (see *"Joystick Calibration Screen"* on page 105).

## 8.1.2. Checking Network

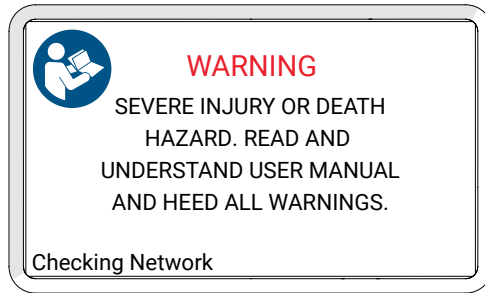

Fig. 211 - Checking network screen

During startup, the system initializes the communications to all the devices on the network. If the network communication fails for any reason, the **Checking Network** message will appear and remain on screen.

Likely causes of this failure:

1. No devices connected to the network.
2. A problem with one of the devices.
3. Cable issue causing the entire network to fail.

Check the connections of the devices or try removing one device at a time from the system to isolate the problem device.

**NOTE:** Always turn off the system power before connecting or disconnecting any devices.

## 8.2. Startup Override

A system maintenance mode may be accessed to correct system issues. Enter the maintenance mode by pressing the handheld controller D-pad while system power is activated. Continue pressing the handheld controller D-pad until the **Startup Override** screen appears.

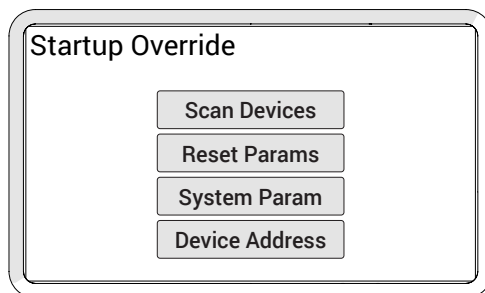

Fig. 212 - Startup override screen

## 8.2.1. Scan Devices

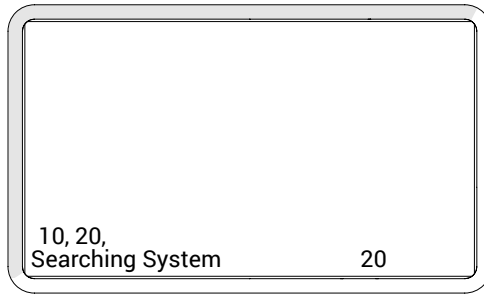

Fig. 213 - Searching System screen

This utility scans the system network for devices. All possible device addresses and speeds are scanned. As devices are found, the address of the devices is displayed. When the scanning is complete, power to the system must be cycled.

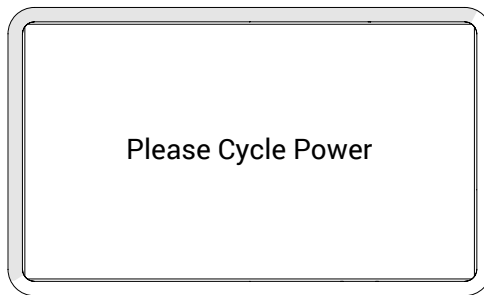

Fig. 214 - Cycle power screen

When a device is connected to the system but is not detected, this most likely indicates an internal device problem.

## 8.2.2. Reset Parameters

If the system parameters become corrupt or a change is made that prevents the system from functioning properly. All system parameters may be restored to their factory settings by selecting this option. When pressing the **Reset Params** button, the changes occur immediately. Power will need to be cycled for the reset to be complete.

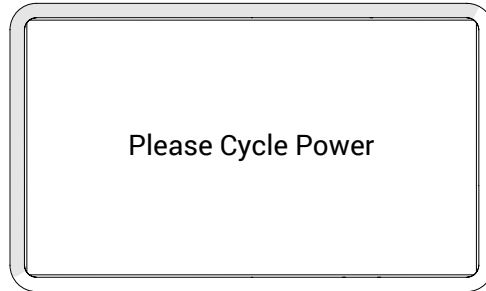

Fig. 215 - Cycle power screen

## 8.2.3. System Parameters

System parameters are factory set to control a variety of functions. These parameters can not be modified. However, special circumstances may occur when modification of these parameters could be recommended by the manufacturer.

Instructions for making changes to the system parameters will only be provided when deemed necessary by the manufacturer.

## 8.2.4. Device Address

Instructions for making changes to the system parameters will only be provided when deemed necessary by the manufacturer.

### 8.3. Additional Issues

| Problem  | Possible Cause  | Solution  |
|--|---|---|
| Handheld controller display does not activate                        | Input power requirements not met.   | Ensure input power meets requirements. (see <i>"Encoder Interface Specifications" on page 9</i> )                               |
|  | Handheld controller not plugged into system controller.                           | Plug handheld controller into system controller. Ensure connectors are dry, clean and connector pins are not bent.              |
|  | Umbilical cable not properly connected.   | Check umbilical cable connections at both ends. Ensure connectors are dry, clean and connector pins are not bent.               |
|  | <b>SKOOT HT</b> system not started.   | Start the <b>SKOOT HT</b> system. (see <i>"System Startup" on page 85</i> )   |
|  | Damaged components in controller, crawler, system controller or cabling.          | Contact manufacturer. (see <i>"Jireh Industries Ltd." on page 1</i> )   |
| Handheld controller display is activated, yet crawler does not drive | Handheld controller is not in correct mode for driving.                           | (see <i>Operation on page 92 for additional details</i> ).  |
|  | Damaged components in handheld controller, crawler, system controller or cabling. | Contact manufacturer. (see <i>"Jireh Industries Ltd." on page 1</i> )   |
| Crawler does not drive and is unreachable                            | See possible causes for problem one of this list.                                 | See solutions for problem one. If the crawler is still unresponsive (see <i>"Retrieval of a Stranded Crawler" on page 115</i> ) |

For technical assistance (see *"Technical Support" on page 115*)

## 8.4. Retrieval of a Stranded Crawler



### **WARNING! FALLING OBJECT HAZARD.**

The tether system must remain active while retrieving the crawler (*i.e. a mechanism or person must be continuously taking up the slack in the tether*).

Should the SKOOT HT crawler become inoperative while out of reach, attempt first, the solutions offered in this manual (*see "Troubleshooting" on page 110*)

If troubleshooting does not rectify the issue, it may be necessary to retrieve the crawler manually. To do so:

1. Press the off push-button turning crawler power off.

**NOTE:** Under normal conditions, the crawler should begin descending slowly.

2. If the crawler stops descending due to some kind of impediment, use a ladder, man lift or scaffolding to assist the crawler in overcoming the obstacle.

**NOTE: FALLING OBJECT HAZARD.** It is **CRUCIAL** that the tether system remains active while retrieving the crawler (*i.e. a mechanism or person must be continuously taking up slack in the tether*).

## 8.5. Technical Support

For technical support contact Jireh Industries (*see "Jireh Industries Ltd." on page 1*).

## SERVICE AND REPAIR



### **WARNING!** ELECTRICAL SHOCK

**HAZARD.** Disconnect the system controller when servicing the equipment. The system controller is powered even when the off push-button is latched in the off position.



### **WARNING!** MAGNETIC MATERIAL.

The wheels of the crawler produce an extremely strong magnetic field which may cause failure or permanent damage to items such as watches, memory devices, CRT monitors, medical devices or other electronics.



Tools, magnets and metal objects can cut, pinch or entrap hands and fingers. **HANDLE WITH CARE.**

Those with pacemakers or ICD's must stay at least 25 cm (10 in) away at all times.



### **WARNING!** DO NOT DISASSEMBLE.

No user-serviceable parts. Disassembling any of the components in this product, beyond the instructions in this user manual, could void the regulatory certifications and/or effect the safety of the product.

# SPARE PARTS

To order accessories or replacement parts for your SKOOT HT system.  
(contact Jireh Industries Ltd. on page 1)

**NOTE:** These drawings are for parts order. This is not a list of kit contents.

## 10.1. SKOOT HT Crawler

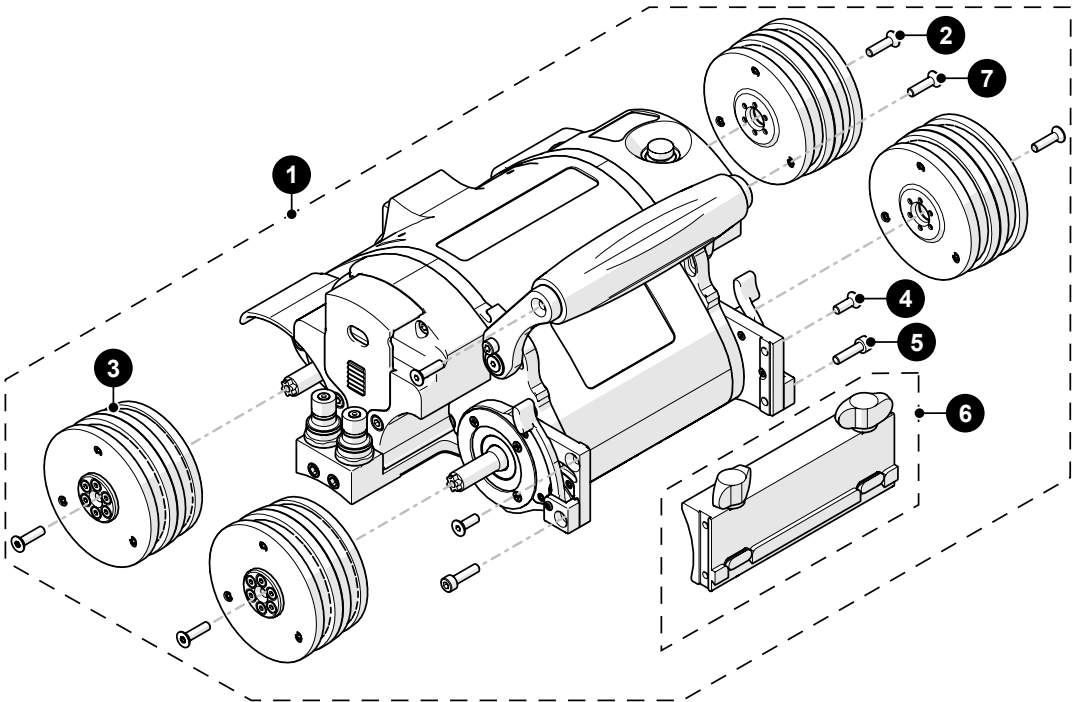

Fig. 216 - SKOOT HT base crawler spare parts

| BOM ID | Part #    | Description                 |
|--------|-----------|-----------------------------|
| 1      | DPA003    | SKOOT HT: Base Crawler      |
| 2      | MD400-016 | FHCS-TX, M4x0.7 X 16 mm, ST |
| 3      | DPS003    | SKOOT HT: Magnetic Wheel    |
| 4      | MD029-012 | FHCS, M4x0.7 X 12 mm, SST   |
| 5      | MD050-016 | SHCS, M4x0.7 X 16 mm, SST   |
| 6      | DNS002    | Dovetail bar attachment     |
| 7      | MD029-016 | FHCS, M4x0.7 X 16 mm, SST   |

## 10.2. SKOOT HT Kit Components

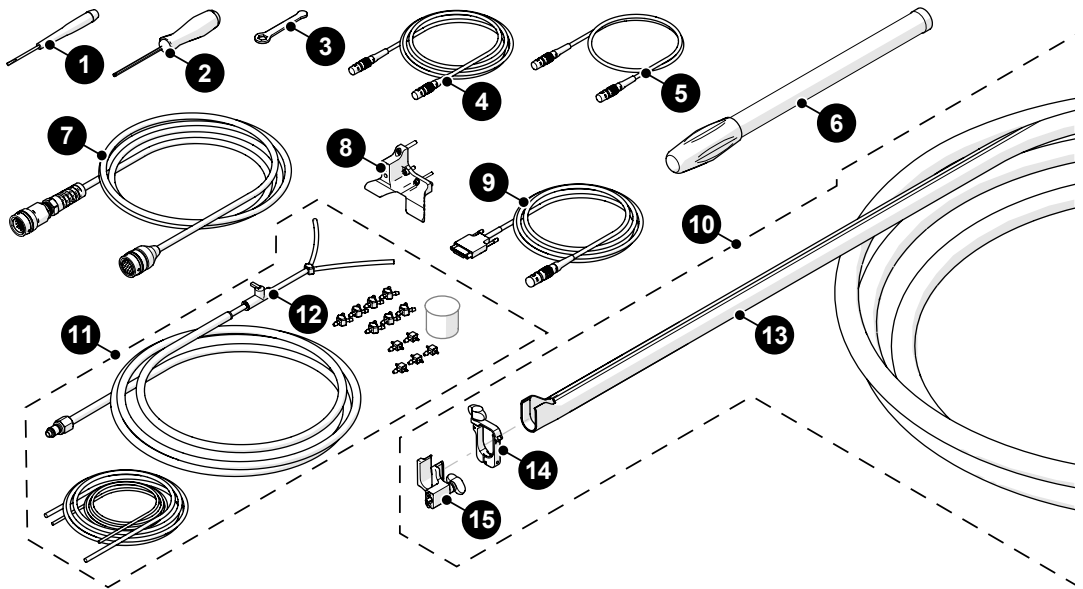

Fig. 217 - Kit components spare parts

| BOM ID | Part #        | Description   |
|--------|---------------|---|
| 1      | EA480         | Flat Driver: 3 mm (0.118 in)                                      |
| 2      | EA414         | Hex Driver: 3 mm (0.118 in)                                       |
| 3      | EA470         | 3/8 in Wrench   |
| 4      | UMA017-06     | Auxiliary Cable 6 m (19.6 ft)                                     |
| 5      | UMA017-01     | Auxiliary Cable 1 m (3.3 ft)                                      |
| 6      | DNS006        | Manipulation Handle   |
| 7      | UMA043-07.5   | SKOOT HT Umbilical 7.5 m (25 ft)                                  |
| 8      | DNG006        | Pry Point   |
| 9      | UMA025-_-07.5 | J300 Encoder Cable (see Encoder Connector Type)                   |
| 10     | CXS113-__     | HT Cable Management (various lengths available)                   |
| 11     | CMG009-__     | Irrigation Kit, 2-4 Probe, Large Tube (various lengths available) |
| 12     | LA034         | Irrigation Shutoff Valve  |
| 13     |               | see HT Cable Management Sleeving                                  |
| 14     | CXS114        | HT Cable Management Clamp   |
| 15     | CXS112        | HT Cable Management Mount: threaded mount                         |

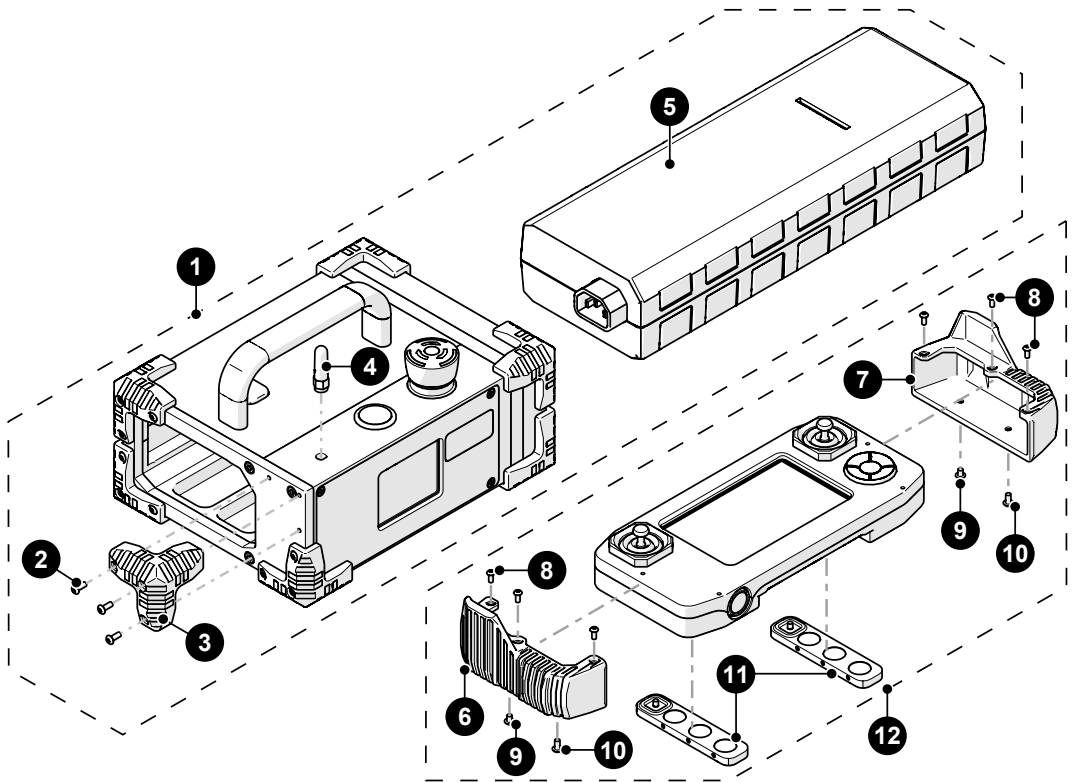

Fig. 218 - Kit components

| BOM ID | Part #    | Description                             |
|--------|-----------|---|
| 1      | ERA002_   | System controller (see Power Cord Type) |
| 2      | MD072-008 | BHCS, M3x0.5 X 8mm, SST                 |
| 3      | DY0011    | Rubber bumper                           |
| 4      | SU004     | Antenna                                 |
| 5      | CXS122    | Power supply                            |
| 6      | DM0088-L  | Handheld controller bumper (left)       |
| 7      | DM0088-R  | Handheld controller bumper (right)      |
| 8      | MD409-006 | BHCS-TX, M2.5x0.5 X 6mm ISO 7380-1 A2   |
| 9      | MD411-004 | BHCS-TX, M3x0.5 X 4mm ISO 7380-1 A2     |
| 10     | MD411-006 | BHCS-TX, M3x0.5 X 6mm ISO 7380-1 A2     |
| 11     | DMS005    | Handheld controller magnet holder       |
| 12     | DMA006    | Handheld controller                     |

### 10.2.1. Encoder Connector Type

| Connector Type | Company/Instrument                                  | Connector Type | Company/Instrument                  |
|----------------|---|----------------|-------------------------------------|
| B              | Olympus OmniScan MX<br>Zetec Topaz                  | G              | Sonotron Isonic 25xx                |
| C              | Olympus Focus LT<br>Zetec Z-Scan<br>Eddyfi Ectane 2 | U              | Sonatest Veo / Prisma               |
| E              | Olympus OmniScan SX/MX2/X3<br>M2M MANTIS/GEKKO LEMO | V              | Pragma PAUT                         |
| F              | TD ( <i>Technology Design</i> )                     | AD             | Sonatest Veo / Prisma - Single Axis |

**NOTE:** Additional encoder connector types are available (contact Jireh Industries Ltd. on page 1).

### 10.2.2. Power Cord Type

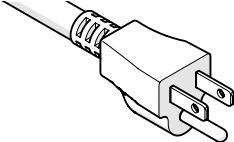
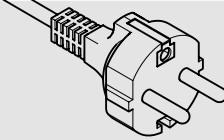
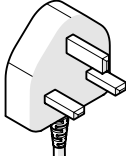
| Connector Type | Part # | Power Cord     |   |
|----------------|--------|----------------|---|
| N              | SL032  | North American |    |
| E              | SL039  | European       |   |
| U              | SL059  | United Kingdom |  |
| Z              |        | No Cord        |   |

### 10.2.3. HT Cable Management Sleeving

CX0537-04.5 4.5 m (14.8 ft)

CX0537-07 7 m (23 ft)

CX0537-29.5 29.5 m (96.8 ft)

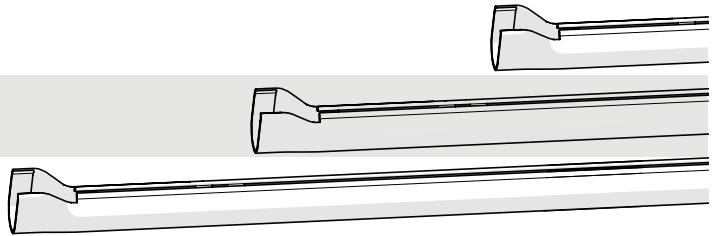
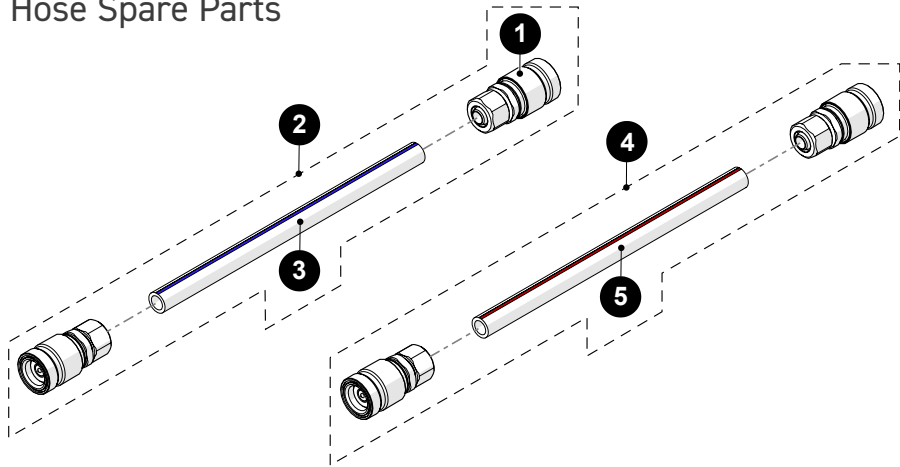

Fig. 219 - HT Cable management sleeving

### 10.3. Hose Spare Parts



| BOM ID | PART #          | Description                                 |
|--------|-----------------|---|
| 1      | DP0056          | Hose Fitting                                |
| 2      | DPA004-BLU-0.75 | Hose Blue                                   |
| 3      | LA139           | Hose Blue, 1/4" ID x 3/8" OD, 7.5 m (25 ft) |
| 4      | DPA004-RED-07.5 | Hose Red                                    |
| 5      | LA140           | Hose Red, 1/4" ID x 3/8" OD, 7.5 m (25 ft)  |

Fig. 220 - Hose spare parts

## 10.4. Probe Holder Frame

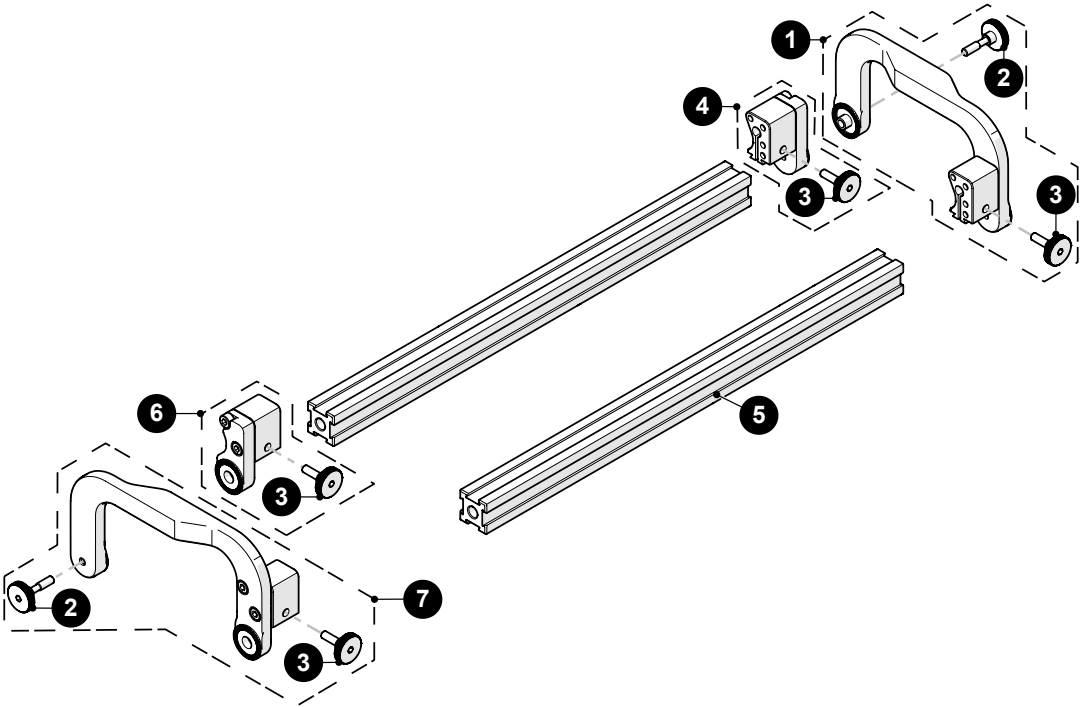

| BOM ID | Part #       | Description   |
|--------|--------------|---|
| 1      | CXS043       | Vertical Probe Holder Side Arm, Left                            |
| 2      | CX0125       | Knob, M4 x 16 mm  |
| 3      | CX0126       | Knurled Knob, M4 x 0.7 x 11.5 mm, 3 mm hex, 4 mm stand off, SST |
| 4      | CXS072-L     | Arm Mount Block, Left   |
| 5      | BG0038-<br>_ | Frame Bar ( <i>see Frame Bar</i> )                              |
| 6      | CXS072-R     | Arm Mount Block, Right  |
| 7      | CXS042       | Vertical Probe Holder Side Arm, Right                           |

Fig. 221 - Probe holder frame parts

## 10.5. Low Profile Probe Holder Frame

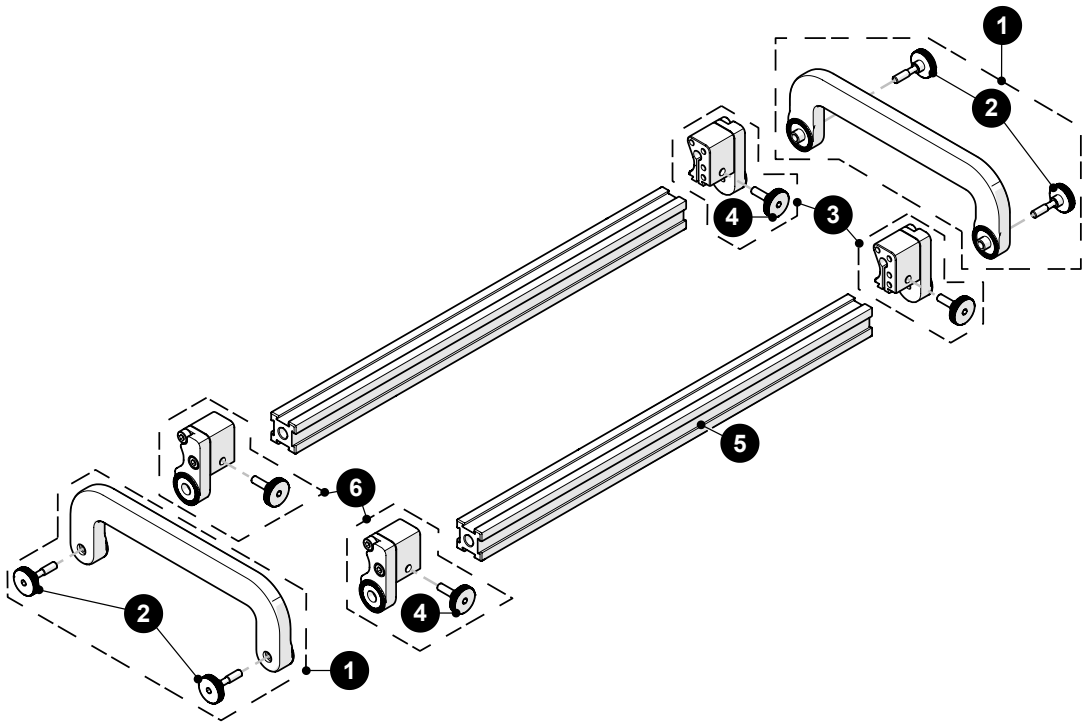

| BOM ID | Part #                  | Description   |
|--------|-------------------------|---|
| 1      | CXS023                  | Low Profile Side Arm  |
| 2      | CX0125                  | Knob, M4 x 16 mm  |
| 3      | CXS072-L                | Arm Mount Block, Left   |
| 4      | CX0126                  | Knurled Knob, M4 x 0.7 x 11.5 mm, 3 mm hex, 4 mm stand off, SST |
| 5      | BG0038- <u>        </u> | Frame Bar ( <i>see Frame Bar</i> )                              |
| 6      | CXS072-R                | Arm Mount Block, Right  |

Fig. 222 - Low profile probe holder frame parts

## 10.6. Pivoting Probe Holder Frame

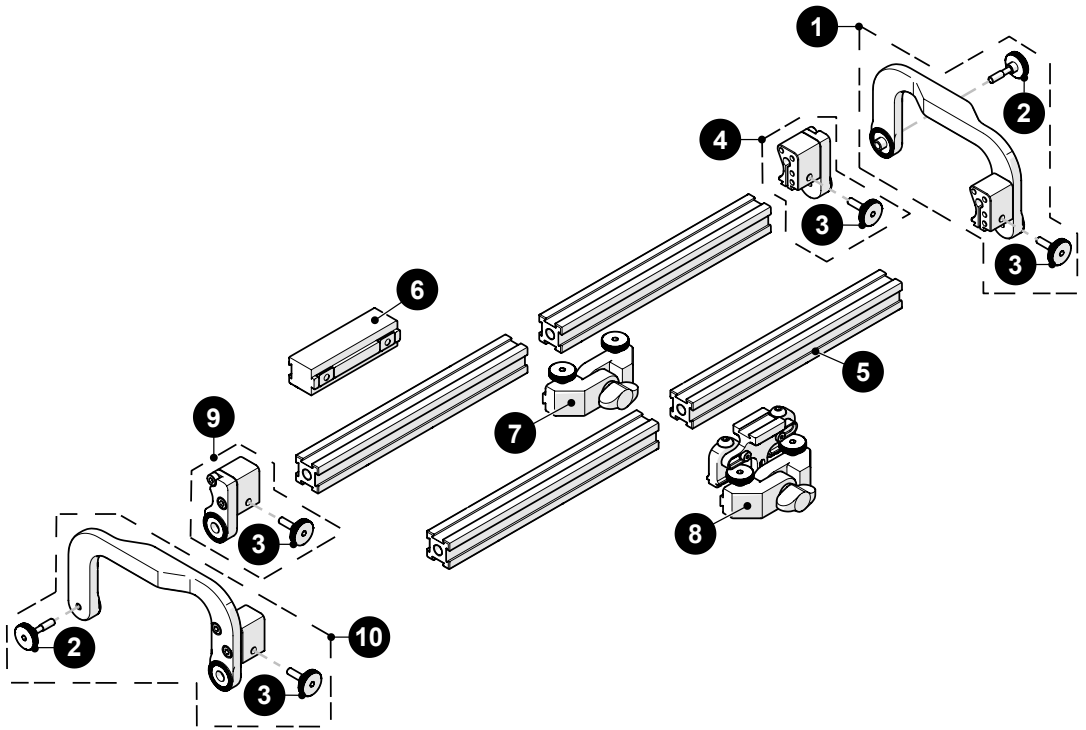

| BOM ID | Part #   | Description   |
|--------|----------|---|
| 1      | CXS043   | Vertical Probe Holder Side Arm, Left                            |
| 2      | CX0125   | Knob, M4 x 16 mm  |
| 3      | CX0126   | Knurled Knob, M4 x 0.7 x 11.5 mm, 3 mm hex, 4 mm stand off, SST |
| 4      | CXS072-L | Arm Mount Block, Left   |
| 5      | BG0038-  | Frame Bar (see Frame Bar)                                       |
| 6      | CXS064   | NAVIC Front Spacer Mount  |
| 7      | CXS055   | Frame Bar Pivot   |
| 8      | CXS059   | Optical Guide Pivot Mount                                       |
| 9      | CXS072-R | Arm Mount Block, Right  |
| 10     | CXS042   | Vertical Probe Holder Side Arm, Right                           |

Fig. 223 - Pivoting probe holder parts

## 10.7. Slip Joint Probe Holder Parts

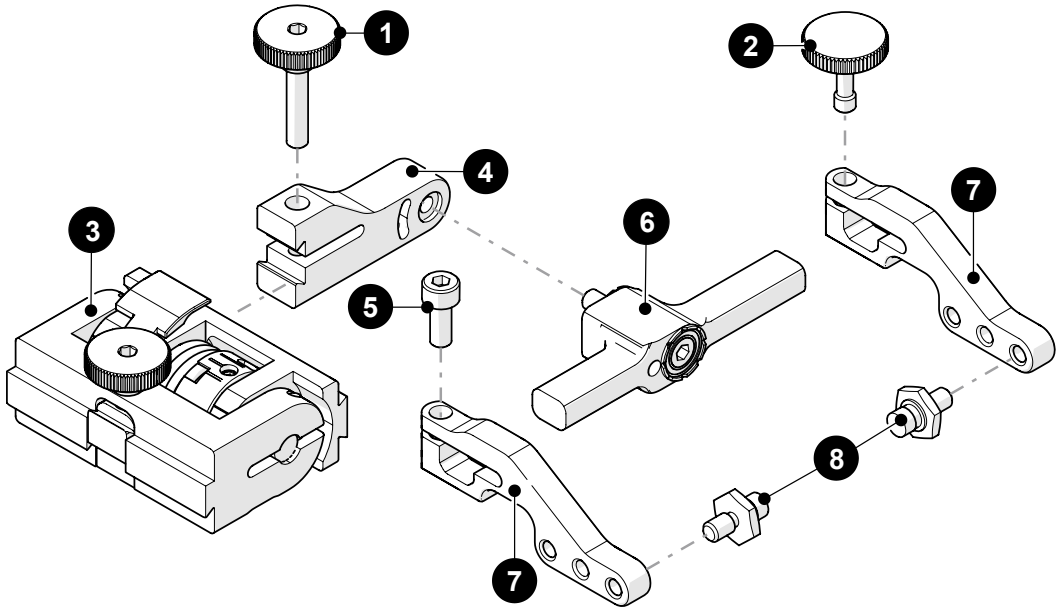

| BOM ID | Part #                     | Description  |
|--------|----------------------------|--|
| 1      | PH0104                     | Knurled Knob, M4 x 0.7 x 18 mm, 4 mm stand off, SST  |
| 2      | PH0082                     | Knurled Knob, M4 x 0.7 x 10 mm, 3 mm stand off, SST  |
| 3      | PHS022                     | Slip Joint Probe Holder Subassembly                  |
| 4      | <i>see Swing Arm Style</i> |  |
| 5      | MD050-010                  | SHCS, M4 x 0.7 x 10 mm, SST                          |
| 6      | <i>see Yoke Style</i>      |  |
| 7      | <i>see Arm Style</i>       |  |
| 8      | PH0011-__                  | Pivot Button Style ( <i>see Pivot Button Style</i> ) |

Fig. 224 - Slip joint probe holder parts

## 10.8. Vertical Probe Holder Parts

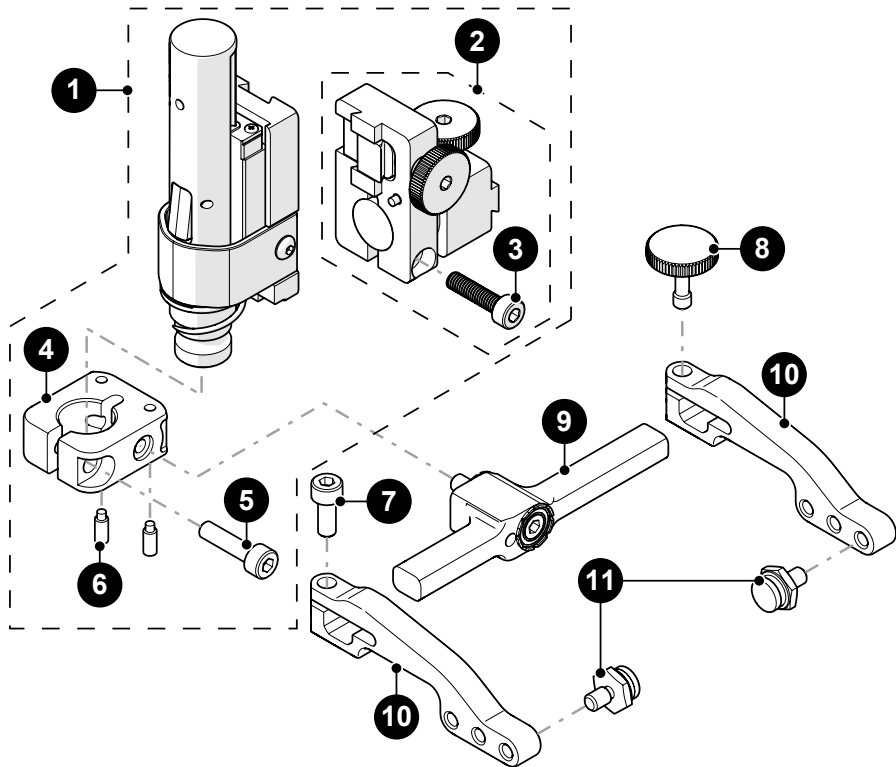

| BOM ID | Part #    | Description   |
|--------|-----------|---|
| 1      | PHS028    | Vertical Probe Holder Subassembly                   |
| 2      | PHS061    | Vertical Probe Holder Sub-Assembly: pivoting mount  |
| 3      | MA307     | Screw, M4x16 mm High Strength SST SHCS              |
| 4      | PH0087    | Vertical Probe Holder Base                          |
| 5      | MD050-016 | SHCS, M4 x 0.7 x 16 mm, SST                         |
| 6      | MA096     | Screw, M3x8 mm Dog Point Set, SST                   |
| 7      | MD050-010 | SHCS, M4 x 0.7 x 10 mm, SST                         |
| 8      | PH0082    | Knurled Knob, M4 x 0.7 x 10 mm, 3 mm stand off, SST |
| 9      |           | see Yoke Style                                      |
| 10     |           | see Arm Style                                       |
| 11     | PH0011-__ | Pivot Button Style (see Pivot Button Style)         |

Fig. 225 - Vertical probe holder parts

## 10.9. Heavy Duty Vertical Probe Holder

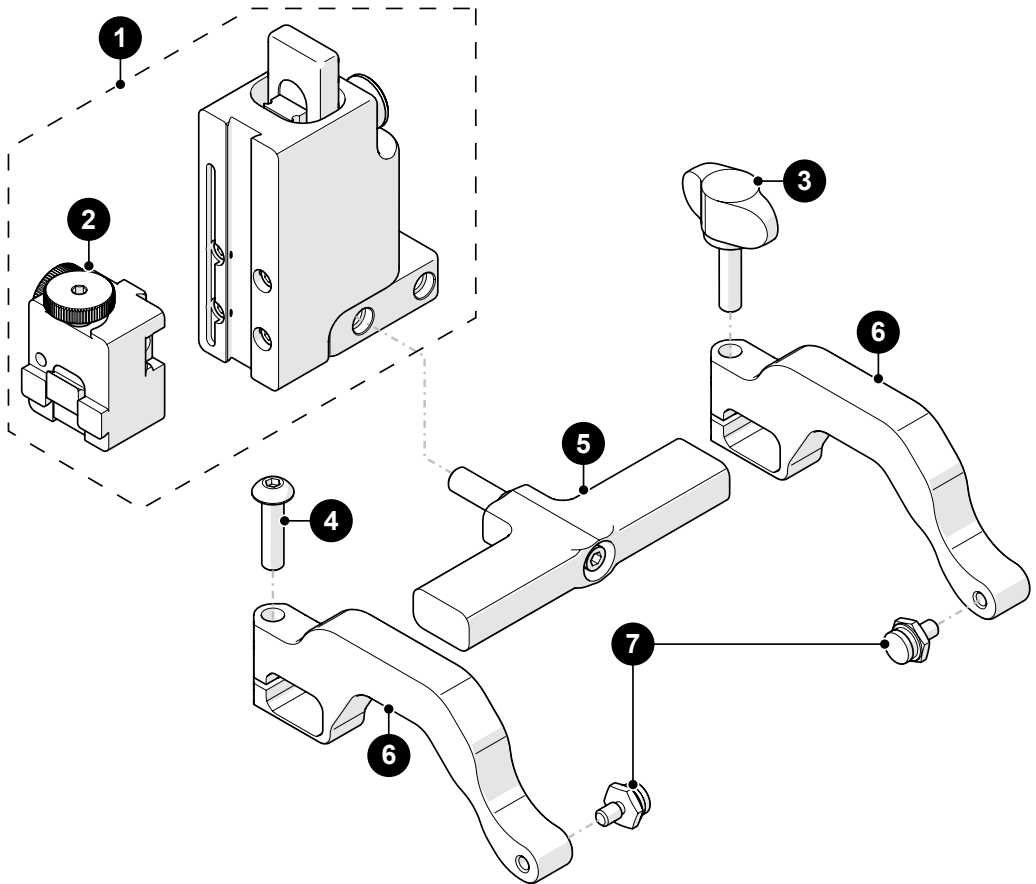

| BOM ID | Part #              | Description  |
|--------|---------------------|--|
| 1      | PHS049              | Heavy Duty Probe Holder Subassembly                  |
| 2      | PHS085              | Heavy Duty Probe Holder Mount                        |
| 3      | EA154               | Probe Holder Arm Adjustment Knob                     |
| 4      | MD074-020           | BHCS, M5 x 0.8 x 20 mm, SST                          |
| 5      |                     | <i>See Heavy Duty Yoke Style</i>                     |
| 6      | PH0165              | Heavy Duty Probe Holder Arm, Standard, Drop          |
| 7      | PH0011- <u>    </u> | Pivot Button Style ( <i>See Pivot Button Style</i> ) |

Fig. 226 - Heavy duty vertical probe holder parts

## 10.10. Corrosion Thickness Probe Holder HT

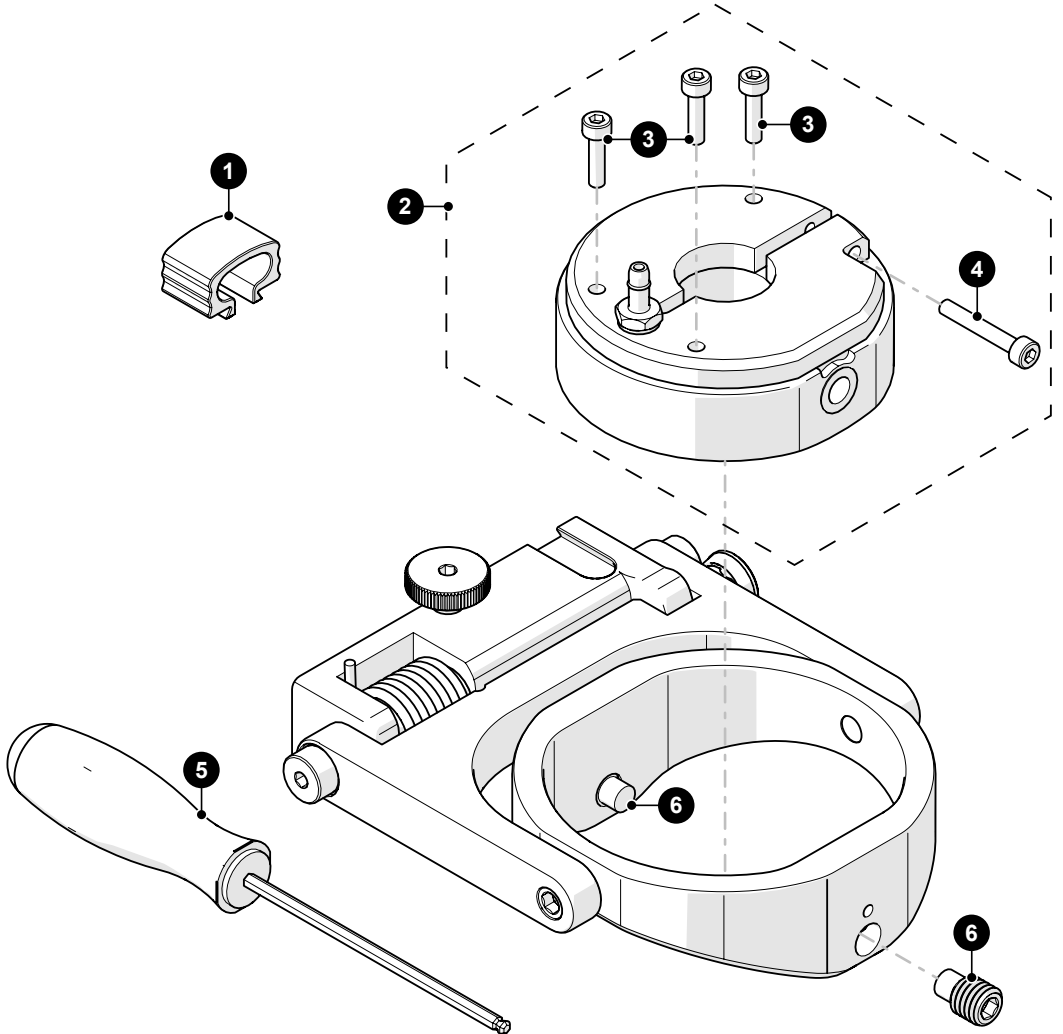

| BOM ID | Part #    | Description  |
|--------|-----------|--|
| 1      | BG0091    | Cable Clip   |
| 2      | PHS079-C  | HT Corrosion Thickness Probe Holder Receptacle<br>- Flat Wear Plate<br>- 19 mm (0.75 in) Diameter Receptacle |
| 3      | MD049-012 | SHCS, M3x0.5 x 12 mm, SST  |
| 4      | MD049-020 | SHCS, M3x0.5 x 20 mm, SST  |
| 5      | EA599     | 2.5 mm (0.098 in) Hex Driver   |
| 6      | MA264     | SHSS, M8 x 1.25 x 12 mm, dog point, SST  |

Fig. 227 - High temperature corrosion thickness probe holder parts

## 10.11. Probe Holder Components

### 10.11.1. Arm Style











| Arm Style                     | Part # |   | Arm Style                  | Part # |  |
|-------------------------------|--------|---|----------------------------|--------|--|
| <b>A</b> Standard, Flat       | PH0090 |  | <b>B</b> Short, Flat       | PH0089 |  |
| <b>C</b> Long, Flat           | PH0099 |  | <b>D</b> Standard, Drop    | PH0093 |  |
| <b>E</b> Short, Drop          | PH0092 |  | <b>F</b> Long, Drop        | PH0094 |  |
| <b>G</b> Standard, Extra-Drop | PH0096 |  | <b>H</b> Short, Extra-Drop | PH0095 |  |
| <b>I</b> Extra-Short, Flat    | PH0159 |  | <b>J</b> Extra-Short, Drop | PH0161 |  |

Fig. 228 - Probe holder arm selection

### 10.11.2. Yoke Style

| Yoke Style        | Part # | Length           |   | Yoke Style    | Part # | Length           |  |
|-------------------|--------|------------------|---|---------------|--------|------------------|--|
| <b>S</b> Standard | PHS052 | 6.3 cm (2.47 in) |  | <b>W</b> Wide | PHS063 | 7.9 cm (3.06 in) |  |

Fig. 229 - Probe holder yoke selection

### 10.11.3. Swing Arm Style

| Swing Arm Style | Part # | Length           |   | Swing Arm Style | Part # | Length           |   |
|-----------------|--------|------------------|---|-----------------|--------|------------------|---|
| Short           | PH0069 | 4.1 cm (1.61 in) |  | Long            | PH0100 | 4.6 cm (1.81 in) |  |

Fig. 230 - Swing arm selection

### 10.11.4. Heavy Duty Yoke Style

| Yoke Style        | Part # | Length           |   | Yoke Style    | Part # | Length            |  |
|-------------------|--------|------------------|---|---------------|--------|-------------------|--|
| <b>S</b> Standard | PHS048 | 8.3 cm (3.26 in) |  | <b>W</b> Wide | PHS047 | 12.2 cm (4.79 in) |  |

Fig. 231 - Heavy duty probe holder yoke selection

### 10.11.5. Pivot Button Style











| Pivot Hole Size                    | Wedge Type       |   | Pivot Hole Size                    | Wedge Type    |   |
|------------------------------------|------------------|---|------------------------------------|---------------|---|
| <b>01</b> 8.0 mm (0.315 in)        | Olympus PA       |  | <b>02</b> 5.0 mm (0.197 in)        | Olympus TOFD  |  |
| <b>03</b> 2.7 mm (0.106 in)        | Sonatest DAAH PA |  | <b>04</b> 9.5 mm (0.375 in)        | -             |  |
| <b>06</b> 3.0 mm (0.118 in)        | -                |  | <b>07</b> 2.3 mm (0.09 in)         | -             |  |
| <b>08</b> Conical Head             | -                |  | <b>09</b> 5 mm (0.197 in) Internal | Zetec PA/TOFD |  |
| <b>11</b> 3 mm (0.118 in) Internal | -                |  | <b>14</b> 4 mm (0.157 in)          | -             |  |

Fig. 232 - Pivot button selection

**NOTE:** Additional probe holder pivot button types are available. (see "Jireh Industries Ltd." on page 1)

# 10.12. Variable Components

## 10.12.1. Frame Bar











| Part #    | Length           |   | Part #    | Length           |  |
|-----------|------------------|---|-----------|------------------|--|
| BG0038-05 | 5 cm (1.97 in)   |  | BG0038-10 | 10 cm (3.94 in)  |  |
| BG0038-15 | 15 cm (5.91 in)  |  | BG0038-20 | 20 cm (7.87 in)  |  |
| BG0038-25 | 25 cm (9.84 in)  |  | BG0038-30 | 30 cm (11.81 in) |  |
| BG0038-35 | 35 cm (13.78 in) |  | BG0038-40 | 40 cm (15.75 in) |  |
| BG0038-45 | 45 cm (17.72 in) |  | BG0038-50 | 50 cm (19.69 in) |  |
| BG0038-55 | 55 cm (21.65 in) |  |           |                  |  |

Fig. 233 - Frame bar selection

## 10.13. Cases

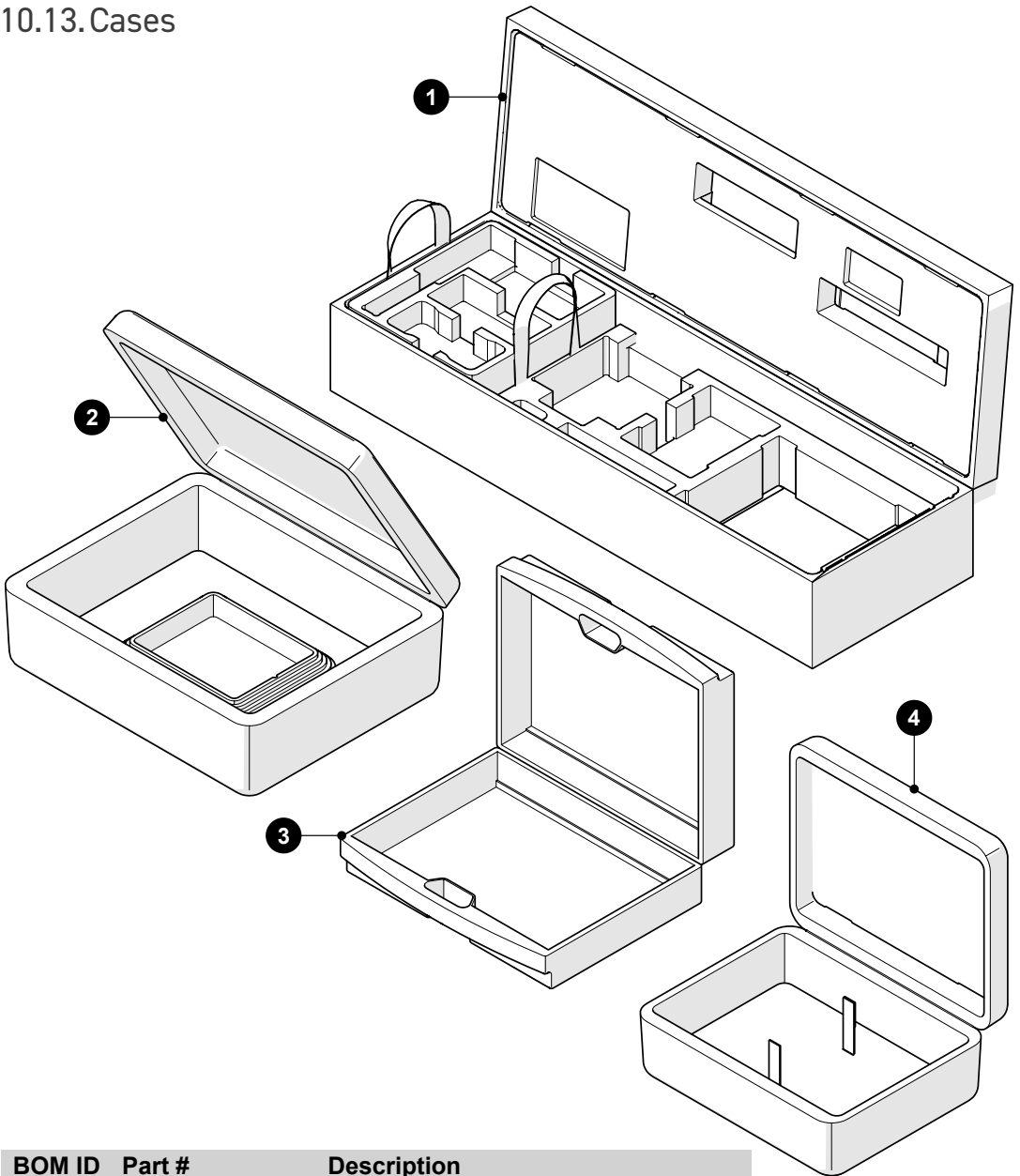

| BOM ID | Part # | Description                         |
|--------|--------|-------------------------------------|
| 1      | DPA007 | SKOOT HT Crawler Case               |
| 2      | CMA016 | Motorized Pump / Umbilical Case     |
| 3      | EA421  | Umbilical Case                      |
| 4      | CXA023 | Umbilical / Probe Holder Frame Case |

Fig. 234 - Cases

## DISPOSAL

### WEEE Directive

In accordance with European Directive on Waste Electrical and Electronic Equipment (WEEE), this symbol indicated that the product must not be disposed of as unsorted municipal waste, but should be collected separately. Refer to Jireh Industries for return and/or collection systems available in your country.



# LIMITED WARRANTY

## WARRANTY COVERAGE

Jireh Industries warranty obligations are limited to the terms set forth below: Jireh Industries Ltd. ("Jireh") warrants this hardware product against defects in materials and workmanship for a period of THREE (3) YEARS from the original date of purchase. If a defect exists, at its option Jireh will (1) repair the product at no charge, using new or refurbished replacement parts, (2) exchange the product with a product that is new or which has been manufactured from new or serviceable used parts and is at least functionally equivalent to the original product, or (3) refund the purchase price of the product. A replacement product/part assumes the remaining warranty of the original product or ninety (90) days from the date of replacement or repair, whichever provides longer coverage for you. When a product or part is exchanged, any replacement item becomes your property and the replaced item becomes Jireh's property. When a refund is given, your product becomes Jireh's property.

## OBTAINING WARRANTY SERVICE

To utilize Jireh's warranty service you must ship the product, at your expense, to and from Jireh Industries. Before you deliver your product for warranty service you must phone Jireh and obtain an RMA number. This number will be used to process and track your product. Jireh is not responsible for any damage incurred during transit.

## EXCLUSIONS AND LIMITATIONS

This Limited Warranty applies only to hardware products manufactured by or for Jireh Industries. This warranty does not apply: (a) to damage caused by accident, abuse, misuse, misapplication, or non-Jireh products; (b) to damage caused by service (including upgrades and expansions) performed by anyone who is not a Jireh Authorized Service Provider; (c) to a product or a part that has been modified without the written permission of Jireh.

**Jireh Industries Ltd.**  
53158 Range Road 224  
Ardrossan, AB T8E 2K4  
Canada  
Phone: 780-922-4534  
jireh.com

HydroFORM™ is a trademark of Olympus

All brands are trademarks or registered trademarks of their respective owners and third-party entities.

Changes or modifications to this unit or accessories not expressly approved by the party responsible for compliance could void the user's authority to operate the equipment.

All specifications are subject to change without notice.

© 2019 - 2025 Jireh Industries Ltd.



Jireh Industries Ltd.  
53158 Range Road 224  
Ardrossan, Alberta  
Canada  
T8E 2K4

780-922-4534

[jireh.com](http://jireh.com)