

6 SPARE PARTS

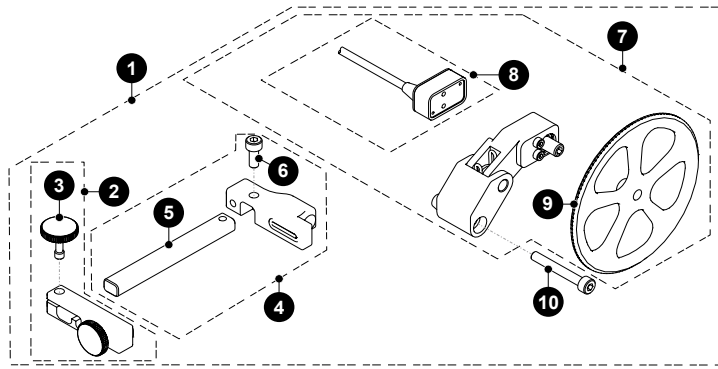

BOM ID	Part #	Description
1	CKA012-X-Y	ODI • HT - Single Probe (see Encoder Connector Type) (alternate cable lengths)
2	CKS012	Adjustable Clamp Arm
3	PH0082	Knurled Knob, M4 x 0.7 x 10 mm, 3 mm stand off, SST
4	CKS020	ODI Encoder Mount, with Clamp Arm: 70 mm (2.8 in)
5	CK0018	Clamp Arm: 70 mm (2.8 in)
6	MD050-010	SHCS, M4x0.7 X 10mm, SST
7	CKS022	ODI • HT Spring-Loaded Encoder (see Encoder Con. Type) (alternate cable lengths)
8	CKS017-X-Y	HT Encoder Brick Replacement (see Encoder Con. Type) (alternate cable lengths)
9	BG0108	High Temperature Encoder Wheel, for high temperature spring-loaded encoder
10	MD050-030	SHCS, M4x0.7 X 30mm, SST

6.1. Encoder Connector Type

Connector Type	Company/Instrument	Connector Type	Company/Instrument
B	Olympus OmniScan MX Zetec Topaz	G	Sonotron Isonic 25xx
C	Olympus Focus LT Zetec Z-Scan Eddyfi Ectane 2	U	Sonatest Veo / Prisma
E	Olympus OmniScan SX/MX2/X3 M2M MANTIS/GEKKO LEMO	V	Pragma PAUT
F	TD (Technology Design)	AD	Sonatest Veo / Prisma - Single Axis

ODI • HT

CK0093 Rev 00
High Temperature Modular Encoder

JIREH

1 SPECIFICATIONS

1.1. Intended Use

The ODI - HT is a clamp-on mini encoder. It is designed to provide encoded linear position of probes for manual scanning operations in a wide range of surface temperatures.



1.2. Performance Specifications

Wedge Width:	0 - 55 mm (2.16 in)
Encoder Resolution:	4.28 counts/mm (108.7 counts/inch)
Environmental Sealing:	Watertight (submersible), Contact JIREH for details

1.3. Operating Environment

The ODI - HT is designed for use in an industrial environment having ambient temperatures between -20°C (-4°F) and 50°C (122°F) with surface temperatures between -20°C (-4°F) to 350°C (662°F).

2 PREPARATION FOR USE

2.1. Probe Attachment

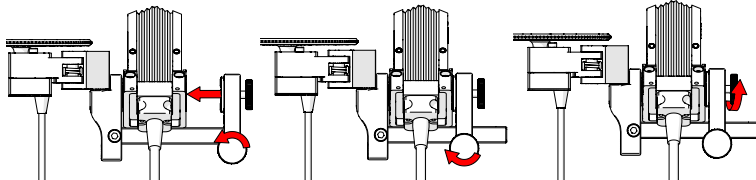

Fig. 1 - Loosen slider knob, move clamp arm

Fig. 2 - Tighten slider knob

Fig. 3 - Tighten clamping knob

2.2. Encoder Setup

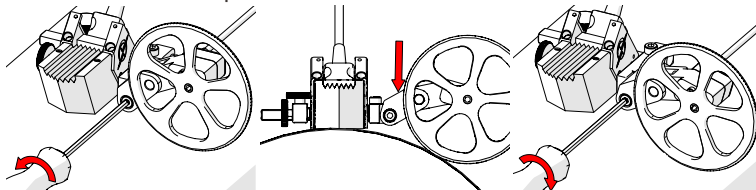

Fig. 4 - Release pivot knob

Fig. 5 - Lower encoder wheel to surface

Fig. 6 - Tighten pivot knob

2.3. Alternate Encoder Position

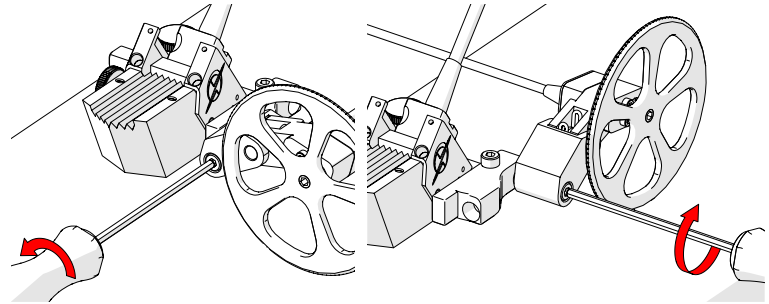

Fig. 7 - Unscrew pivot knob and remove encoder

Fig. 8 - Tighten pivot knob and follow steps 2.2.

3 OPERATION

Hold the wedge flat against the scanning surface and scan straight in the desired direction, ensuring that the encoder wheel is in contact with the scanning surface and is rotating in the direction of the scan.

4 MAINTENANCE

Wipe the scanner clean as required. Do not soak or submerge the scanner in a cleaner or solvent of any kind.

5 TROUBLESHOOTING

Problem	Possible Cause	Solution
Encoder not incrementing	Encoder wheel, not in contact with scanning surface.	Rotate the pivot joint until the wheel is in contact with the scanning surface and the spring joint is slightly depressed (see 2.2)
	Encoder wheel is not running in the desired scanning direction.	Unscrew the pivot knob separating the encoder. Place the encoder in an alternate encoder position (see 2.3).
	Encoder connector is not correctly connected to a scanning device.	Check the scanning device's instructions on properly connecting an encoder.