

**STIX**

BG0135 Rev 00.3

Magnetic Corrosion Scanner

**J** JIREH

---

# SAFETY WARNINGS \ PRECAUTIONS

## **KEEP THIS MANUAL – DO NOT LOSE**

THIS MANUAL IS PART OF THE **STIX** AND MUST BE RETAINED FOR THE LIFE OF THE PRODUCT. PASS ON TO SUBSEQUENT OWNERS.

Ensure any amendments are incorporated with this document.



**WARNING!** The **STIX** is designed for a specific use. Using the **STIX** outside of its intended use could cause damage to the product. Read and understand this manual before using.



**WARNING! MAGNETIC MATERIAL.** The wheels of this device produce a magnetic field which may cause failure or permanent damage to items such as watches, memory devices, CRT monitors, medical devices or other electronics.



People with pacemakers or ICD's must stay at least 25 cm (10 in) away at all times.



**WARNING!** Do **NOT** operate scanner in an explosive environment. Do **NOT** operate scanner in the presence of volatile substances.



**WARNING! DO NOT DISASSEMBLE.** No user-serviceable parts. Disassembling any of the components in this product, beyond the instructions in this user manual, could void the regulatory certifications and/or effect the safety of the product.



The **WEEE** symbol indicates that the product must not be disposed of as unsorted municipal waste, but should be collected separately.

(see *Disposal* on page 43)

---

# TABLE OF CONTENTS

<b>1</b>	<b>Identification</b> .....	<b>1</b>
	1.1. Product Brand .....	1
	1.2. Manufacturer .....	1
<b>2</b>	<b>Product Specifications</b> .....	<b>2</b>
	2.1. Intended Use .....	2
	2.1.1. Operating Limits .....	2
	2.1.2. Operating environment .....	2
	2.2. Dimensions and Weight .....	2
	2.3. Environmental Sealing.....	3
	2.4. Performance Specifications .....	3
<b>3</b>	<b>Definitions</b> .....	<b>4</b>
	3.1. Definition of Symbols .....	4
	3.2. Definitions of Terms .....	4
<b>4</b>	<b>System Components</b> .....	<b>5</b>
	4.1. Base System Components .....	5
	4.1.1. STIX Corrosion Chain Frame .....	5
	4.1.2. Corrosion Link .....	5
	4.1.3. Non-Encoded Corrosion Link .....	5
	4.1.4. J100 Encoder Cable .....	6
	4.1.5. PPS Encoder .....	6
	4.1.6. Corrosion Slider .....	6
	4.1.7. Magnetic Wheel.....	7
	4.1.8. Heavy Duty Vertical Probe Holder .....	7
	4.1.9. Frame Bar with Ruler .....	7
	4.1.10. Irrigation Kit .....	8
	4.1.11. Cable Management, Dovetail Mount .....	8
	4.1.12. Tools .....	8

4.1.13. Case .....	8
4.2. Compatible Components .....	9
4.2.1. Encoder Adapter .....	9
4.2.2. Preamp Bracket .....	9
4.2.3. HydroFORM™ Cart .....	9
4.3. Tools .....	10

**5**

**Preparation for use ..... 11**

5.1. Standard Configuration .....	11
5.2. Corrosion Link .....	12
5.3. Non-Encoded Corrosion Link .....	12
5.3.1. Corrosion link adjustment.....	13
5.3.2. Mounting a Frame Bar .....	14
5.3.3. Index Encoder Connection .....	14
5.3.4. Encoder Connection .....	14
5.3.5. Brake .....	15
5.3.6. Wheel Removal/Installation .....	15
5.4. Carrier .....	16
5.5.1. Index Nuts .....	16
5.5.2. Indexing Latch .....	17
5.5.3. Indexing Plunger .....	18
5.5.4. Carrier Cable Clip .....	19
5.6. Heavy Duty Vertical Probe Holder .....	20
5.6.1. Probe Holder Setup .....	20
5.6.2. Probe Holder Vertical Adjustment.....	21
5.6.3. Probe Holder Left/Right Conversion .....	22
5.6.4. Yoke Substitution .....	23
5.6.5. Probe Holder 90° Adjustment.....	24
5.7. Frame Bar with Ruler .....	24
5.8. Pivot Buttons .....	24
5.9. Index Encoder .....	25
5.10. Cable Clips.....	26
5.11. Cable Management .....	26
5.11.1. Cable Management Dovetail Mount .....	27
5.11.2. Cable Management Setup .....	27
5.11.3. Clamp Setup .....	28
5.12. Preamp Bracket .....	29
5.12.1. Mounting Preamp Bracket .....	29
5.12.2. Attaching Preamp with Screws .....	29
5.12.3. Attaching Preamp with Velcro Straps .....	30

<b>6</b>	<b>Operation</b> .....	<b>31</b>
	6.1. Setup of a STIX on a Scanning Surface .....	31
<b>7</b>	<b>Maintenance</b> .....	<b>33</b>
<b>8</b>	<b>Troubleshooting</b> .....	<b>34</b>
	8.1. Technical Support .....	34
<b>9</b>	<b>Service and Repair</b> .....	<b>35</b>
<b>10</b>	<b>Spare Parts</b> .....	<b>36</b>
	10.1. Corrosion Scanner .....	36
	10.2. Kit Contents .....	37
	10.2.1. STIX Corrosion Case .....	38
	10.2.2. Encoder Connector Type .....	39
	10.2.3. Cable Management .....	39
	10.3. Heavy Duty Vertical Probe Holder .....	40
	10.4. Probe Holder Components .....	41
	10.4.1. Heavy Duty Yoke Style .....	41
	10.4.2. Pivot Button Style .....	41
	10.5. Accessories .....	41
	10.5.1. Magnetic Wheel Kit .....	41
	10.5.2. Preamp Bracket .....	42
	10.5.3. HydroFORM™ Cart .....	42
<b>11</b>	<b>Disposal</b> .....	<b>43</b>
<b>12</b>	<b>Limited Warranty</b> .....	<b>44</b>

# IDENTIFICATION

## 1.1. Product Brand

This user manual describes the proper safety precautions, setup and use of the **STIX** manual magnetic corrosion scanner.

## 1.2. Manufacturer

Distributor:

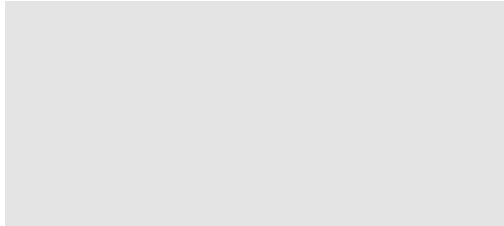

Manufacturer:

Jireh Industries Ltd.  
53158 Range Road 224  
Ardrossan, Alberta, Canada  
T8E 2K4  
Phone: 780.922.4534  
jireh.com

# PRODUCT SPECIFICATIONS

## 2.1. Intended Use

The **STIX** magnetic scanner is a manually operated scanner which provides corrosion scanning.

### 2.1.1. Operating Limits

Category	Parameter	Specification
Inspection surface	Minimum OD, circumferential pipe/tube range ( <i>standard</i> )	20.3 cm (8 in)
	Minimum OD, circumferential pipe/tube range ( <i>reduced</i> )	10.2 cm (4 in)*

\* 10.2 cm (4 in) diameter scanning is made possible when using the reduced width of the corrosion link (see *Corrosion link adjustment* on page 13).

### 2.1.2. Operating environment

The **STIX** magnetic scanner is designed for use in an industrial environment that is between -20 to 50° C (-4° to 122° F).

## 2.2. Dimensions and Weight

Encoder cable length (standard kit)	5 m (16.4 in)
<b>A</b> Scanner width	76.7 cm (30.2 in)
<b>B</b> Scanner depth	28.5 cm (11.2 in)
<b>C</b> Scanner height	15.1 cm (5.9 in)
Scanner weight	3.9 kg (8.6 lb)

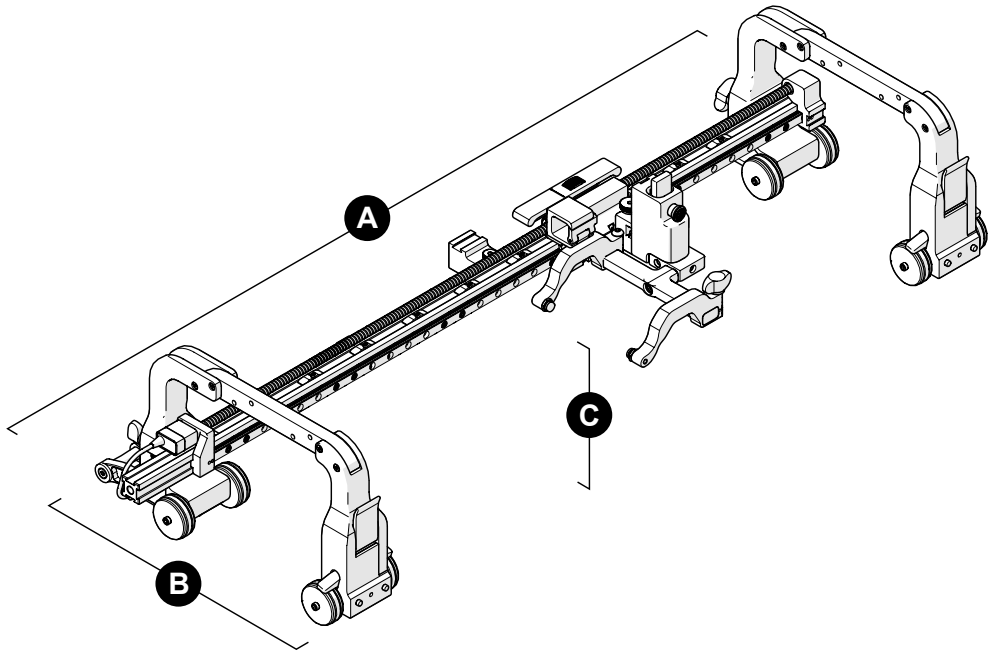

Fig. 1 - Scanner dimensions

## 2.3. Environmental Sealing

Dust-tight, watertight (*not submersible*).

## 2.4. Performance Specifications

Scan encoder resolution	16.3 counts/mm (414.5 counts/inch)
Index encoder resolution	40.3 counts/mm (1023.9 counts/inch)

## DEFINITIONS

### 3.1. Definition of Symbols



Instructions to 'look here' or to 'see this part.'

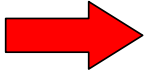

Denotes movement. Instructing users to carry out an action in a specified direction.

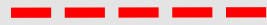

Indicates alignment axis.



Alerts the user that the view has changed to a reverse angle.

### 3.2. Definitions of Terms

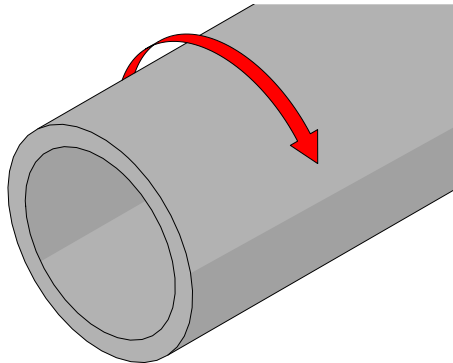

Fig. 2 - Circumferential scanning

Circumferential

Direction of scan travel is around the circumference of the pipe/tube (Fig. 2).

# SYSTEM COMPONENTS

## 4.1. Base System Components

### 4.1.1. STIX Corrosion Chain Frame BGA025-

The corrosion chain frame includes the system braking and an internal positional encoder.

The slider system allows positioning of a probe holder.

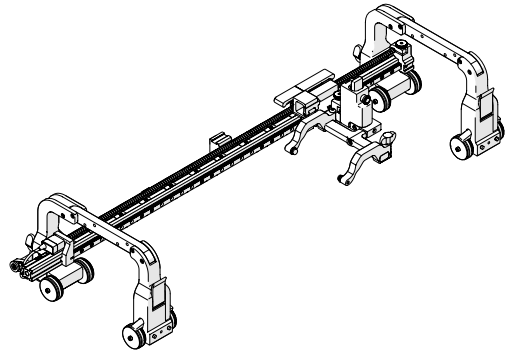

Fig. 3 - Corrosion chain frame

### 4.1.2. Corrosion Link BGA026-

The corrosion chain frame includes the system braking and an internal positional encoder.

The slider system allows positioning of a probe holder.

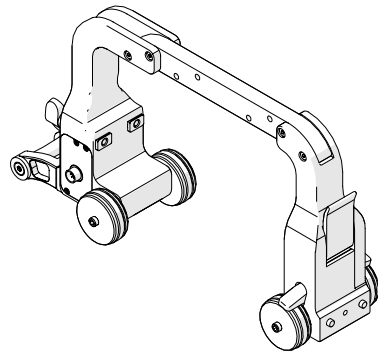

Fig. 4 - Corrosion link

### 4.1.3. Non-Encoded Corrosion Link BGA027-

The corrosion chain frame includes the system braking and an internal positional encoder.

The slider system allows positioning of a probe holder.

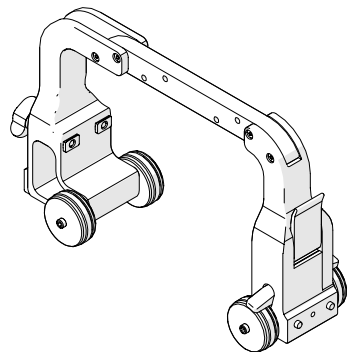

Fig. 5 - Non-encoded corrosion link

#### 4.1.4. J100 Encoder Cable UMA026-

The encoder cable connects the system to the user's instrument.  
(Fig. 6).

Various encoder cable styles are available for various instruments.

**NOTE:** *Inspect the cable and connectors for damage before use. When damage is evident, the cable must **NOT** be used.*

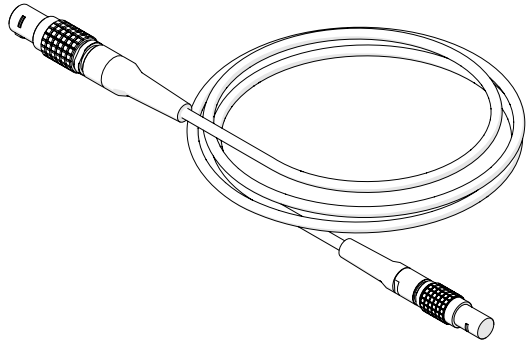

Fig. 6 - J100 Encoder cable

#### 4.1.5. PPS Encoder DKS009-

The PPS Encoder offers the capability of two-axis encoding on the STIX scanner (Fig. 7).

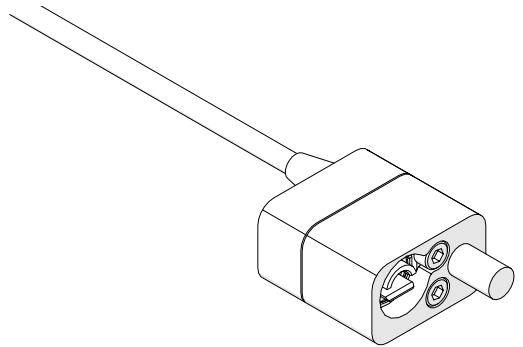

Fig. 7 - PPS encoder

#### 4.1.6. Corrosion Slider DKS010-

The PPS Encoder offers the capability of two-axis encoding on the STIX scanner (Fig. 8).

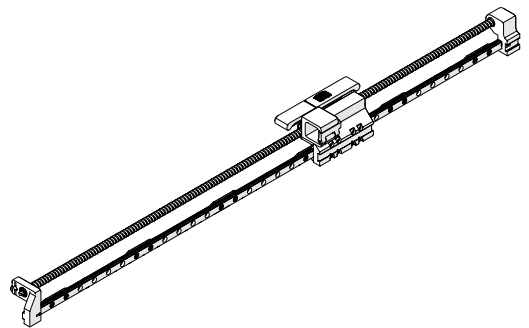

Fig. 8 - Corrosion slider

#### 4.1.7. Magnetic Wheel BTS031

Magnetic wheels allow the scanner to adhere to ferrous materials. (Fig. 9).

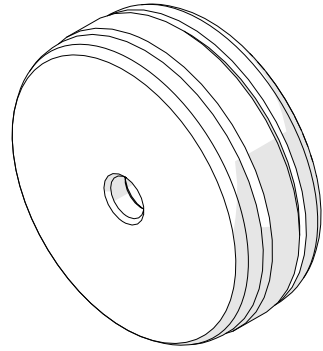

Fig. 9 - Magnetic wheel

#### 4.1.8. Heavy Duty Vertical Probe Holder PHS043-

The heavy duty vertical probe holder is designed to carry larger probes. Available with various arm, yoke and pivot buttons, the heavy duty vertical probe holder exerts more downforce on a large footprint probe/wedge (Fig. 10).

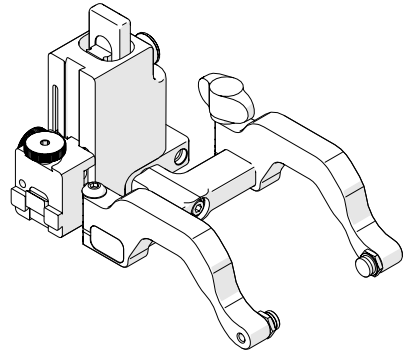

Fig. 10 - Heavy duty vertical probe holder

#### 4.1.9. Frame Bar with Ruler BG0090-

Frame bars are used to mount probe holders, probe positioning systems and other accessories. The frame bar includes a ruler with 1 mm measurements. The ruler can be used to assist with the positioning of index nuts (Fig. 11).

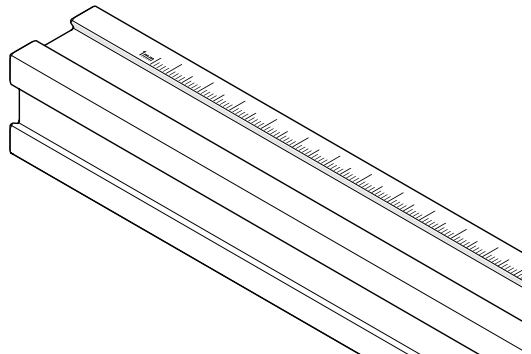

Fig. 11 - Frame bar with ruler

#### 4.1.10. Irrigation Kit CMG007

The irrigation kit provides a variety of hoses, fittings, connectors, and splitters commonly used during non-destructive inspection (*Fig. 12*).

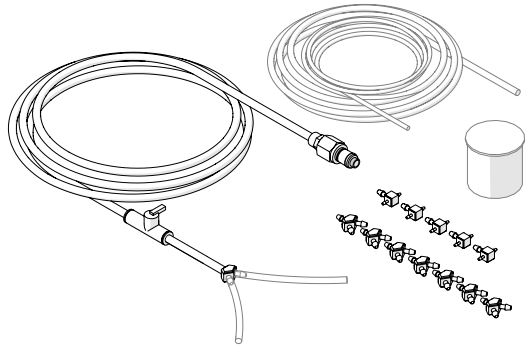

Fig. 12 - Irrigation kit

#### 4.1.11. Cable Management, Dovetail Mount CES044-

The cable management provides a means of protecting and organizing cables, tubes and hoses. The dovetail mount connects to the Dovetail QuickLink (*Fig. 13*).

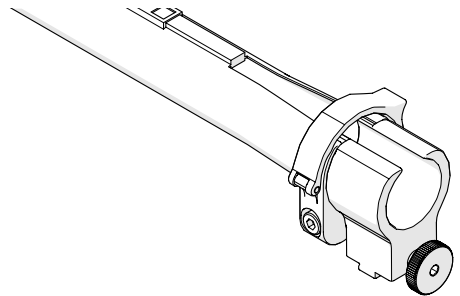

Fig. 13 - Cable management, dovetail mount

#### 4.1.12. Tools

Several tools are included for various scanner and accessory adjustments. (*see Tools on page 10*).

#### 4.1.13. Case

The system is provided with a rugged carrying case.

## 4.2. Compatible Components

### 4.2.1. Encoder Adapter UMA010-

Adapt a scanner's existing encoder connector to a different encoder style (Fig. 14).

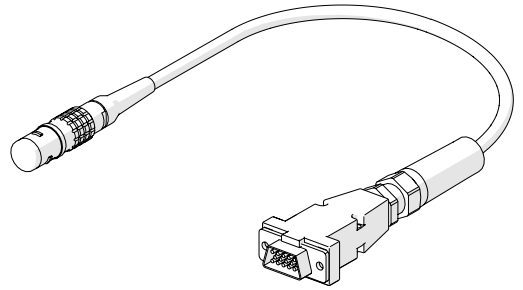

Fig. 14 - Encoder adapter

### 4.2.2. Preamp Bracket CES029-

A bracket that mounts to a scanner to hold various preamps (Fig. 15).

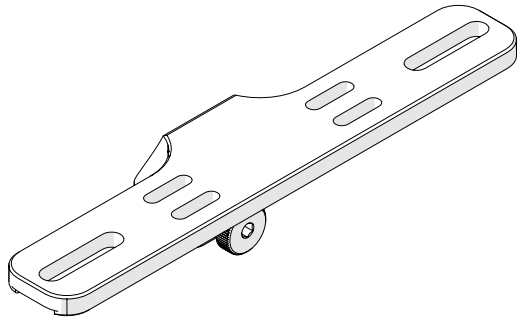

Fig. 15 - Preamp bracket

### 4.2.3. HydroFORM™ Cart PHS092

The HydroFORM™ Cart - 2nd Generation carries the Olympus HydroFORM™ probe. The cart is mounted within the arms of the heavy duty vertical probe holder (Fig. 16).

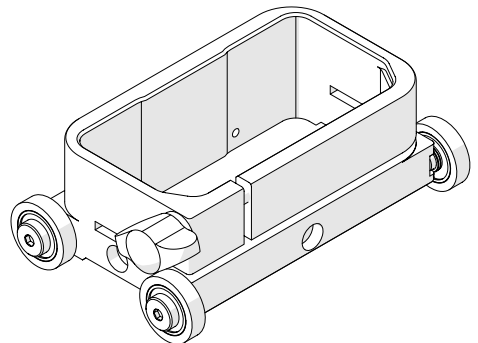

Fig. 16 - HydroFORM cart

## 4.3. Tools

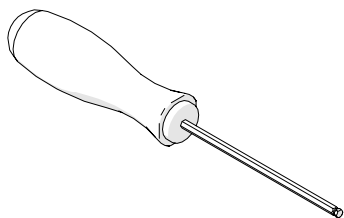

Fig. 17 - 3 mm hex driver  
EA414

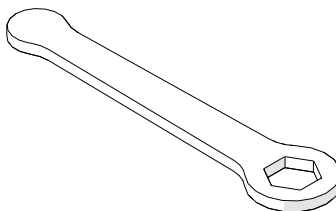

Fig. 18 - 3/8 in wrench  
EA470

The 3 mm hex driver (*Fig. 17*) is sufficient for all typical operations and adjustments of the **STIX**.

The 3/8 in wrench (*Fig. 18*) removes and installs buttons on the probe holders.

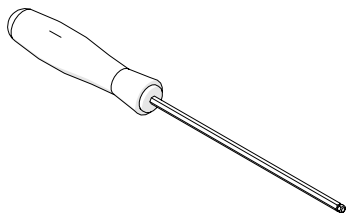

Fig. 19 - 2 mm hex driver  
EA476

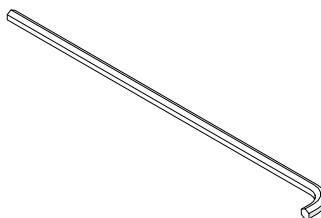

Fig. 20 - Short 2 mm hex wrench  
CE0137

The 2 mm hex driver (*Fig. 19*) allows for adjustment of the index nuts.

The short 2 mm hex wrench

# PREPARATION FOR USE

## 5.1. Standard Configuration

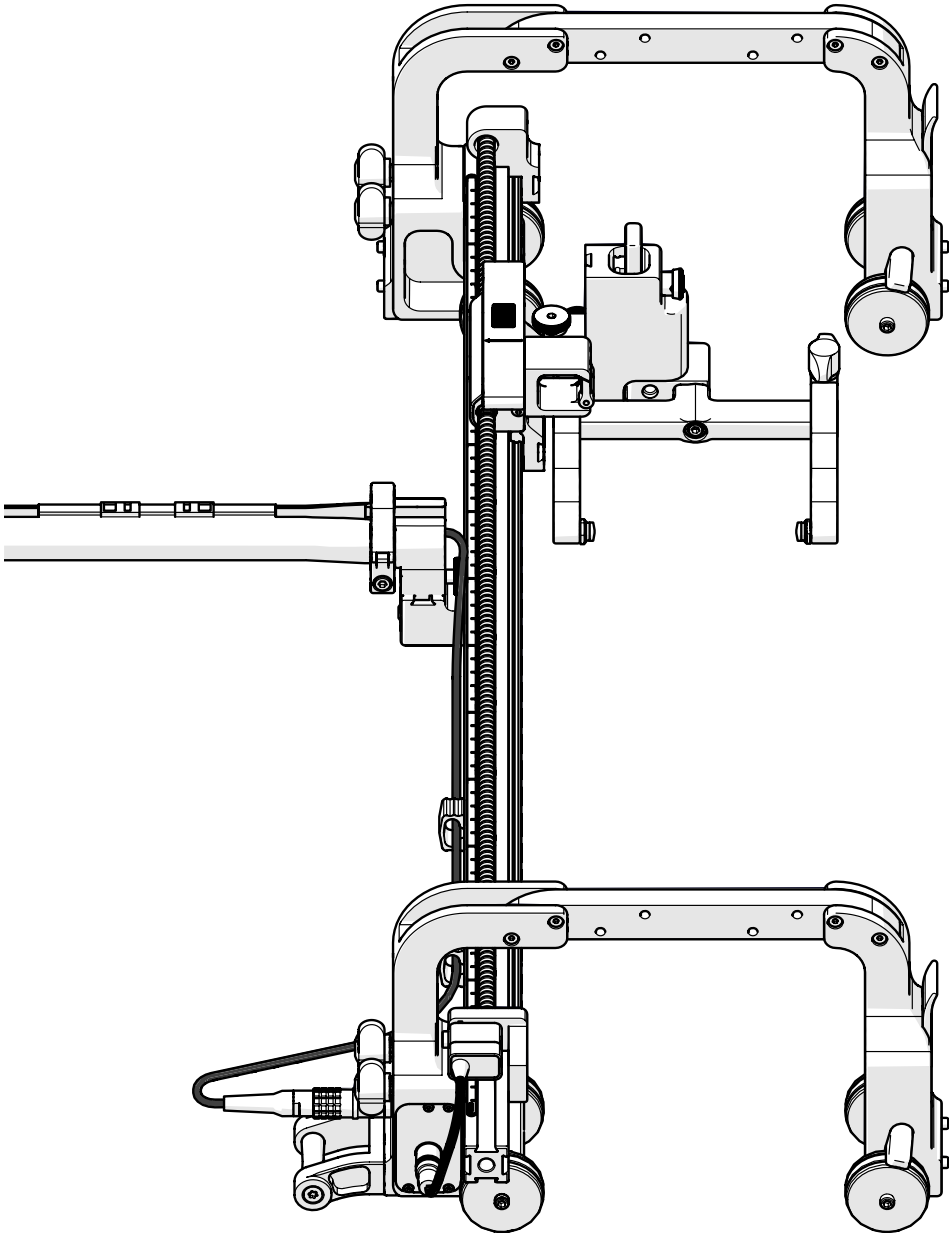

Fig. 21 - Standard configuration

## 5.2. Corrosion Link

The corrosion link (Fig. 22) provides braking for the system and an internal positional encoder connected to the wheels. The Y-axis connector on the side of the link connects to the PPS encoder.

A mounting point for the frame bar is also provided.

The corrosion link length can be adjusted to increase the scanner diameter range and allow for probe clearance.

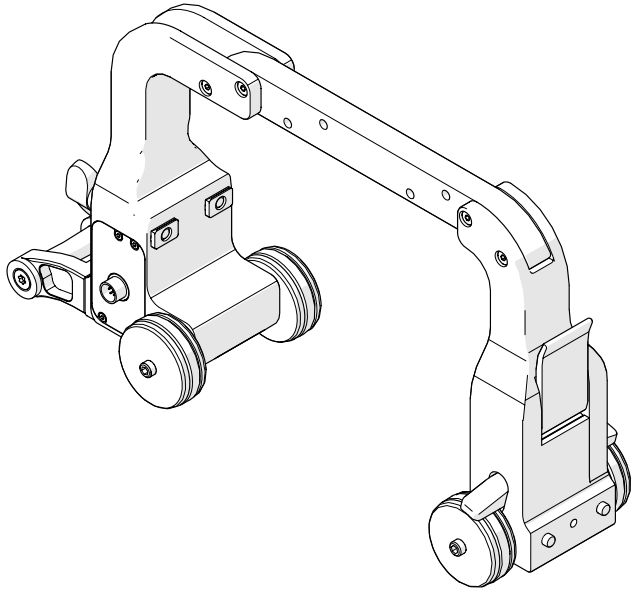

Fig. 22 - Corrosion link

## 5.3. Non-Encoded Corrosion Link

The non-encoded corrosion link (Fig. 23) provides braking for the system.

A mounting point for the frame bar is also provided.

The corrosion link length can be adjusted to increase the scanner diameter range and allow for probe clearance.

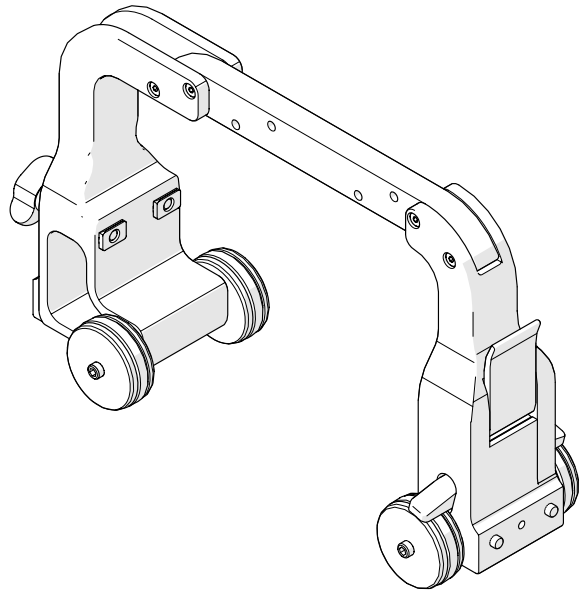

Fig. 23 - Non-Encoded Corrosion Link

### 5.3.1. Corrosion link adjustment

To achieve the minimum diameter pipe/tube scan range of 10.2 cm (4 in), the corrosion and non-encoded corrosion links must be adjusted as follows.

**NOTE:** The large yoke of the heavy duty probe holder must be replaced with the standard yoke to allow the carrier to fit under the corrosion links (see *Yoke Substitution* on page 23).

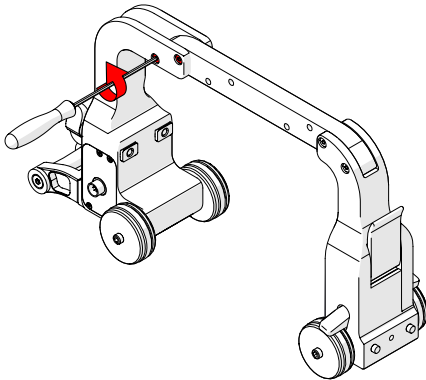

Fig. 24 - Remove shoulder screws

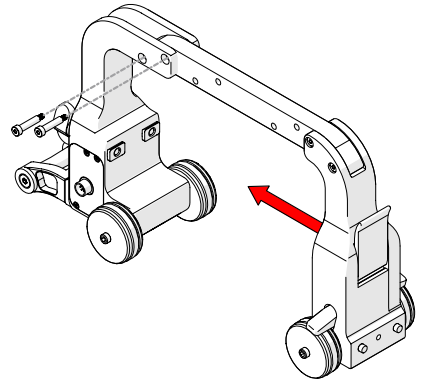

Fig. 25 - Align screw holes

1. Use the supplied 2 mm hex driver to remove the two shoulder screws (Fig. 24).
2. With the two shoulder screws removed, position the two halves of the corrosion link closer together, align the screw holes and insert the shoulder screws (Fig. 25).
3. Tighten the two shoulder screws with the supplied 2 mm hex driver (Fig. 26).

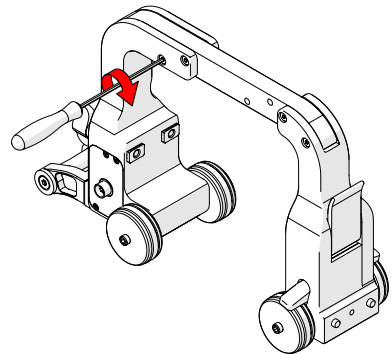

Fig. 26 - Tighten shoulder screws

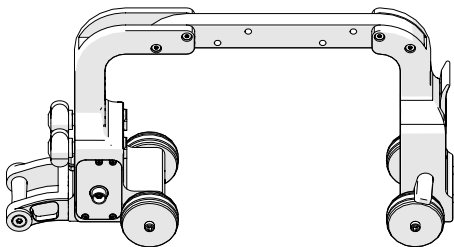

Fig. 27 - Standard configuration

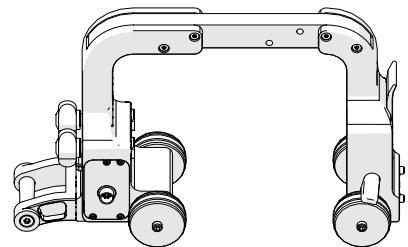

Fig. 28 - Reduced configuration

### 5.3.2. Mounting a Frame Bar

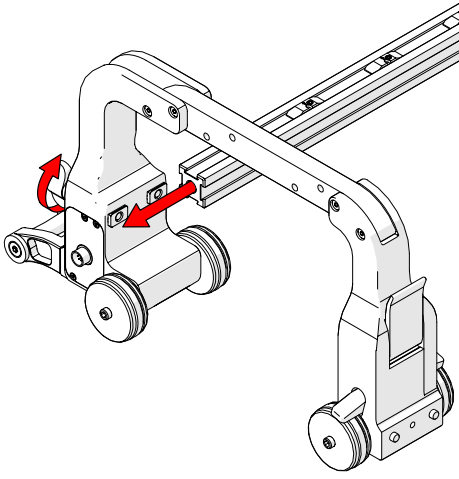

Fig. 29 - Loosen wing knobs

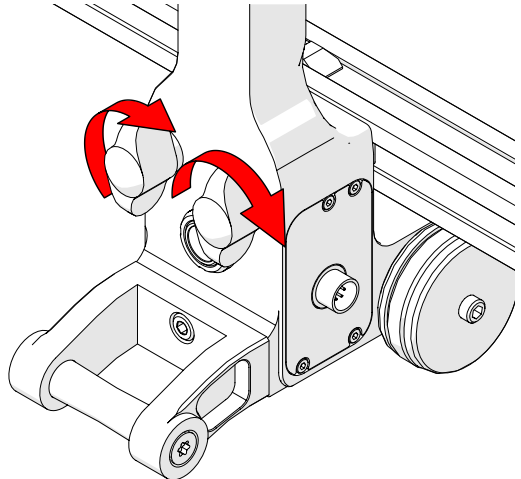

Fig. 30 - Tighten wing knobs

Ensure the two black wing knobs are loose (*Fig. 29*). Slide the frame bar along the dovetail nuts of the corrosion link (*Fig. 29*). When the frame bar is positioned where appropriate, tighten the two black wing knobs (*Fig. 30*).

### 5.3.3. Index Encoder Connection

The index encoder connection (*Fig. 31*) is located along the side of the corrosion link. The cable from the PPS encoder (see *Index Encoder on page 25*) connects to this point.

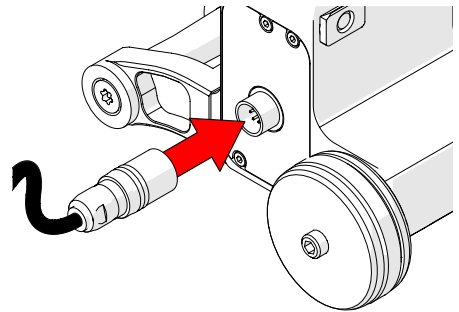

Fig. 31 - Index encoder connection

### 5.3.4. Encoder Connection

The encoder connection (*Fig. 32*) is located at the rear of the corrosion link. The encoder cable connects here. The opposite end of the encoder cable connects to the user's instrument.

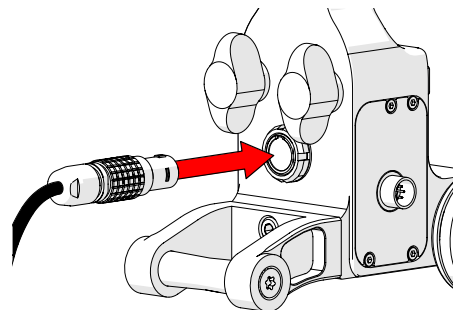

Fig. 32 - Encoder connection

### 5.3.5. Brake

The red lever on the corrosion and non-encoded corrosion links brake the system. Press the lever down to activate the brake.

**TIP:** When the brake is engaged, and the scanner is moved, this may loosen the wheels from the axle. Grip the wheel tightly and retighten the axle with the 3 mm hex driver.

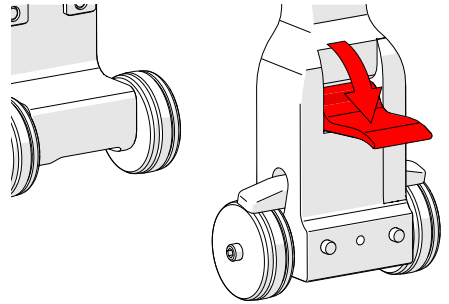

Fig. 33 - Brake

### 5.3.6. Wheel Removal/Installation

Tightly grip the wheel to be removed by hand. Loosen the wheel from the axle using the supplied 3 mm hex driver (Fig. 34).

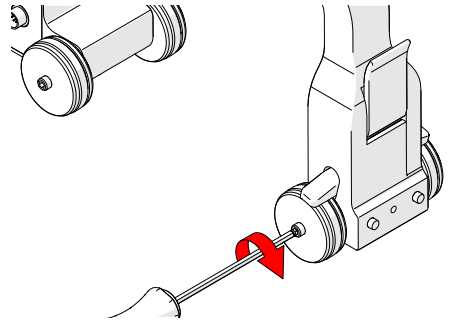

Fig. 34 - Wheel removal/installation



**WARNING! MAGNETIC MATERIAL.** The magnetic wheel kit produce a magnetic field which may cause failure or permanent damage to items such as watches, memory devices, CRT monitors, medical devices or other electronics. People with pacemakers or ICD's must stay at least 25 cm (10 in) away.

## 5.4. Carrier

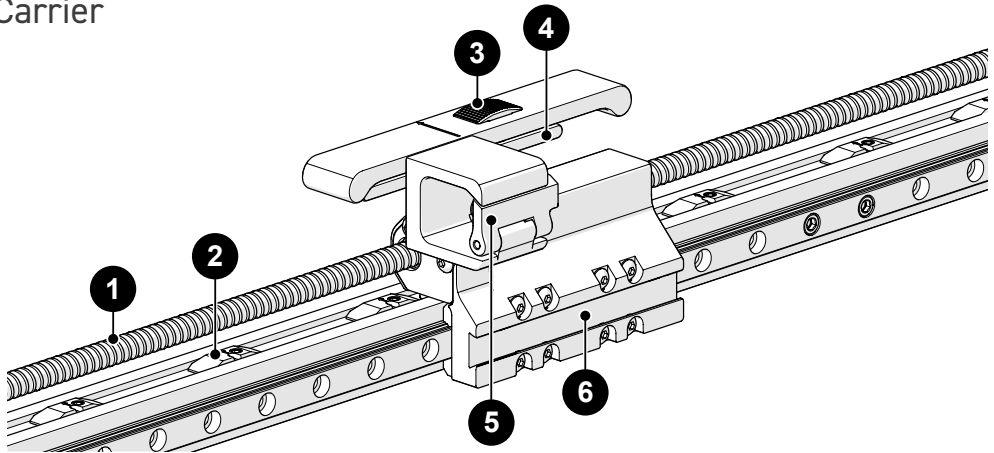

Fig. 35 - Carrier identification

With the use of a leadscrew, the carrier can move along the length of the frame bar.

- |   |                |   |                       |
|---|----------------|---|-----------------------|
| 1 | Leadscrew      | 4 | Indexing plunger      |
| 2 | Index nut      | 5 | Carrier cable clip    |
| 3 | Indexing latch | 6 | Probe holder dovetail |

### 5.5.1. Index Nuts

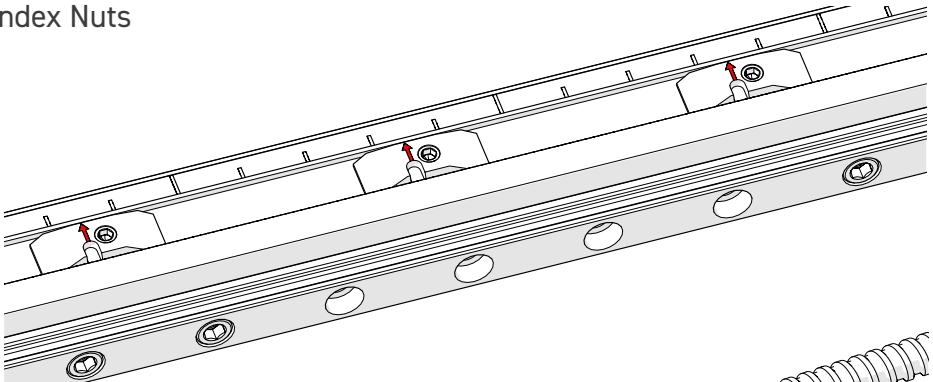

Fig. 36 - Index nuts

The index nuts (Fig. 36), located along the frame bar, offer index positions during scans. The arrow on each nut confirms alignment with the ruler on the frame bar.

Using the short 2 mm hex wrench (Fig. 37), position the index nut arrow using the frame bar ruler to set the desired spacing.

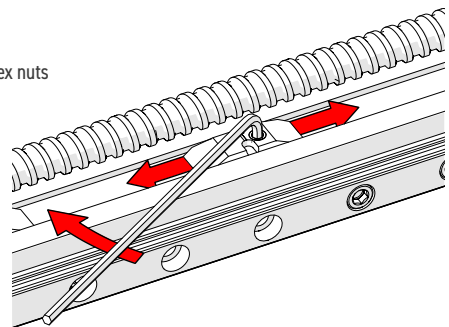

Fig. 37 - Position index nuts

**NOTE:** The index nuts can be repositioned, and placement of the index nuts works in conjunction with typical probe specifications. Excessive adjustment of the index nuts is not recommended.

The manufacturer configures the index nuts with a spacing of 58 mm (2.28 in). The spacing at the end of the scanner's final position is 48 mm (1.89 in).

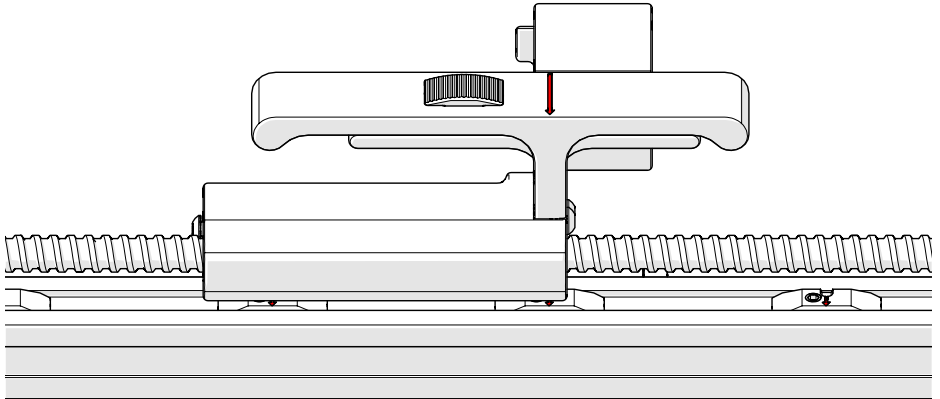

Fig. 38 - Index nuts

The arrow found on the carrier's handle references the arrow on the corresponding index nut (Fig. 38).

### 5.5.2. Indexing Latch

The indexing latch toggles between stopping the carrier at each index nut or sliding freely.

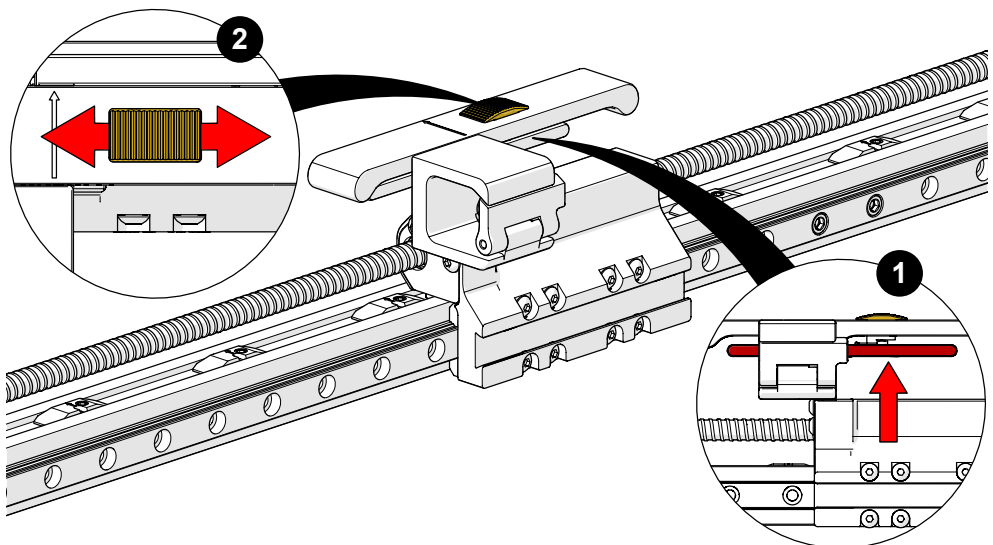

Fig. 39 - Carrier indexing latch

1. Lift the **1** indexing plunger and move the **2** indexing latch to the left to permanently disengage the indexing plunger (Fig. 40). This will allow the carrier to move freely along the leadscrew (Fig. 41).
2. Lift the **1** indexing plunger and move the **2** indexing latch to the right to activate the indexing plunger (see *Indexing Plunger* on page 18 for additional details).

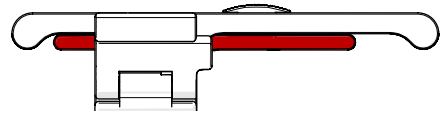

Fig. 40 - Indexing plunger disengaged

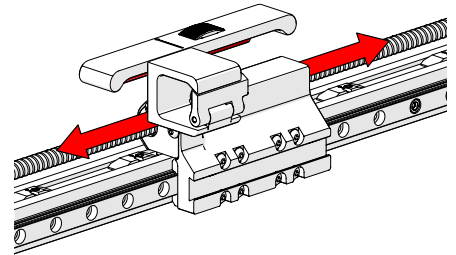

Fig. 41 - Carrier moves freely

### 5.5.3. Indexing Plunger

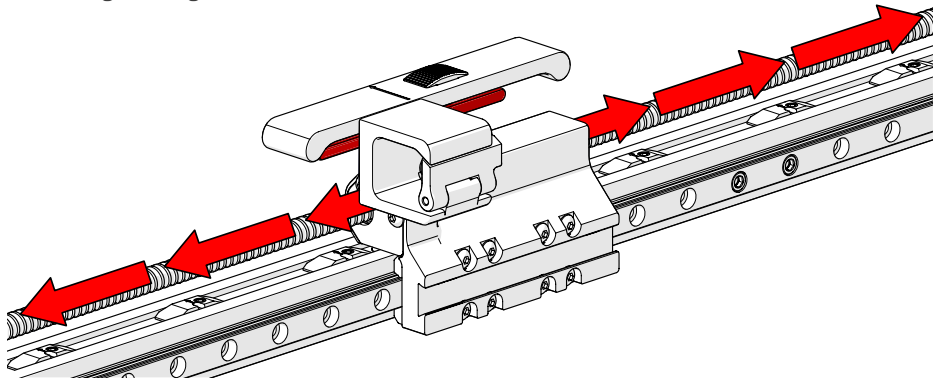

Fig. 42 - Indexing plunger

1. Lift the indexing plunger and move the carrier slightly to release the carrier from the locked position. Lower the indexing plunger and slide the carrier to the next index location where the carrier will lock in position (Fig. 39).

#### 5.5.4. Carrier Cable Clip

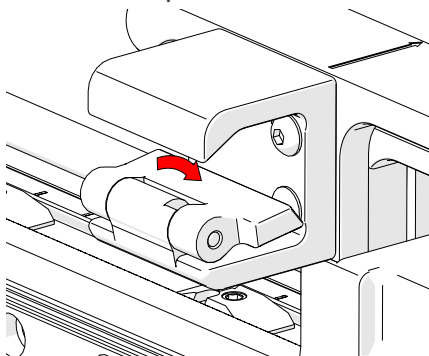

Fig. 43 - Carrier cable clip flap

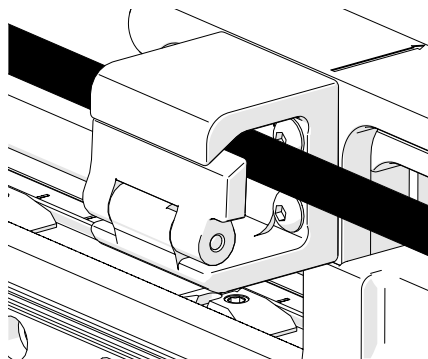

Fig. 44 - Carrier cable clip

1. Push the cable clip flap down (*Fig. 43*) to insert the necessary cables and hoses (*Fig. 44*).

## 5.6. Heavy Duty Vertical Probe Holder

- A Latch
- B Probe Holder Arm Adjustment Knob
- C Yoke
- D Probe Holder Arms
- E Pivot Buttons
- F Arm Clamp Screw
- G Probe Holder Adjustment Knob
- H Vertical Adjustment Knob

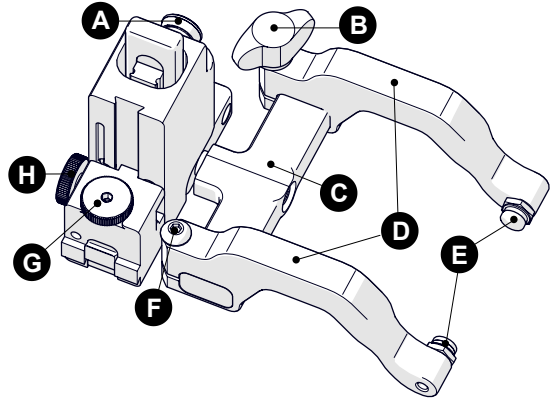

Fig. 45 - Heavy duty vertical probe holder

### 5.6.1. Probe Holder Setup

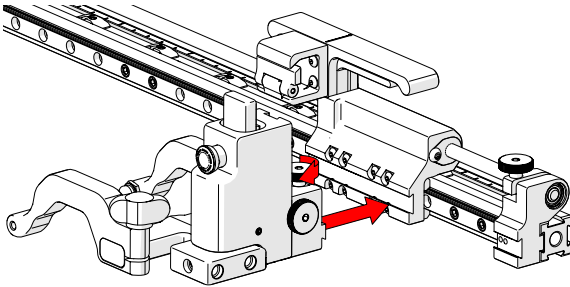

Fig. 46 - Mount probe holder to carrier

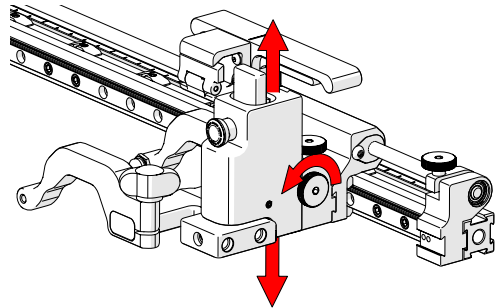

Fig. 47 - Vertical adjustment

1. Loosen the probe holder adjustment knob (Fig. 46) and mount the heavy duty vertical probe holder's dovetail jaw to the carrier.
2. The vertical adjustment knob (Fig. 47) allows height adjustment of the heavy duty vertical probe holder. This adjustment also controls the probe holder's spring tension.

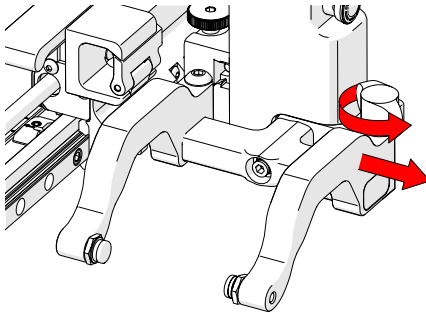

Fig. 48 - Remove outer arm

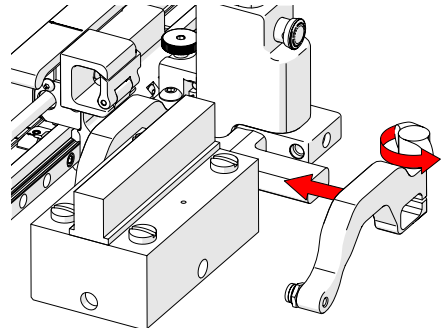

Fig. 49 - Adjust inner arm

3. Loosen the probe holder adjustment knob and remove the outer probe holder arm (Fig. 48).
4. Loosen the arm clamp screw (Fig. 49).
5. Place the wedge on the pivot button of the inner probe holder arm (Fig. 49).

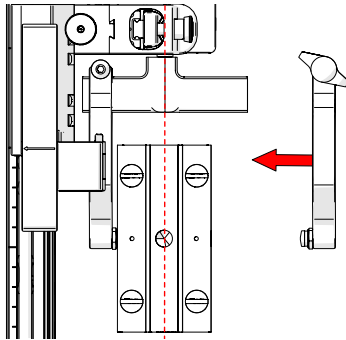

Fig. 50 - Remove outer arm

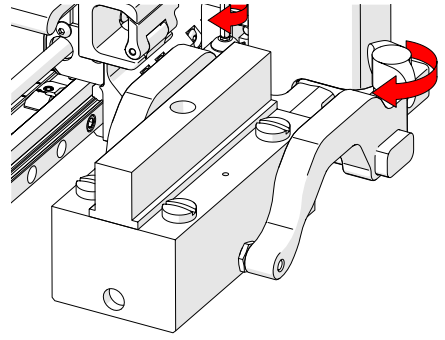

Fig. 51 - Pivot buttons

6. Align the middle of the wedge with the centre of the yoke (Fig. 50).
7. Tighten both the probe holder adjustment knob and the arm clamp screw (Fig. 51) while ensuring the wedge remains centred with the yoke.

### 5.6.2. Probe Holder Vertical Adjustment

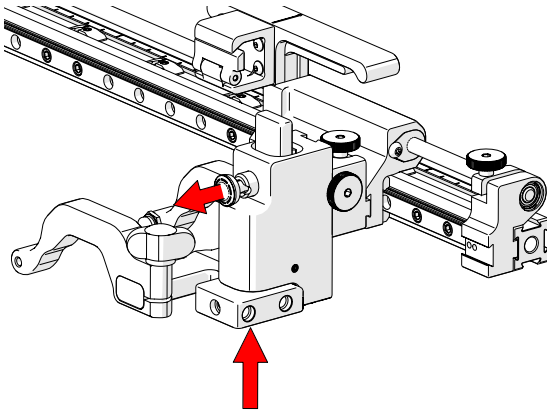

Fig. 52 - Press up and pull latch

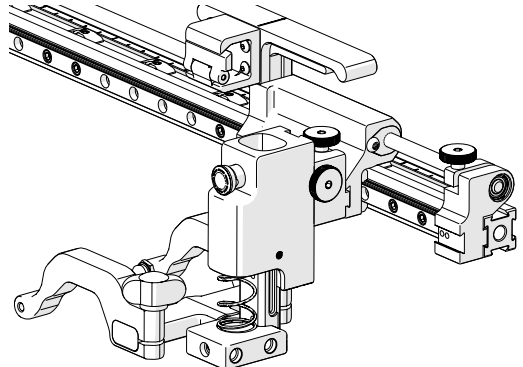

Fig. 53 - Lowered toward scan surface

1. Gently lift the heavy duty probe holder and simultaneously pull the latch (Fig. 52). This action will unlock the probe holder. Slowly lower the probe holder towards the scan surface (Fig. 53).

### 5.6.3. Probe Holder Left/Right Conversion

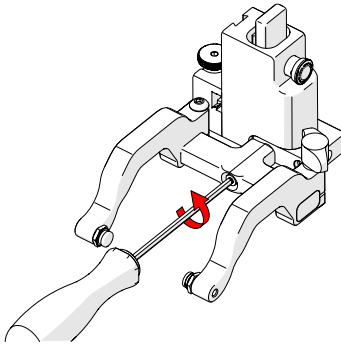

Fig. 54 - Remove yoke

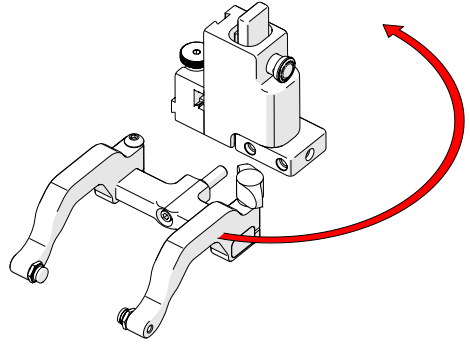

Fig. 55 - Orient to opposite side

1. Using the supplied 3 mm driver, unscrew the yoke (Fig. 54).
2. Position the yoke and arms on the opposite side of the probe holder (Fig. 55).

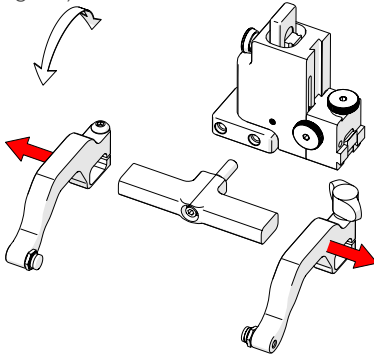

Fig. 56 - Remove probe holder arms

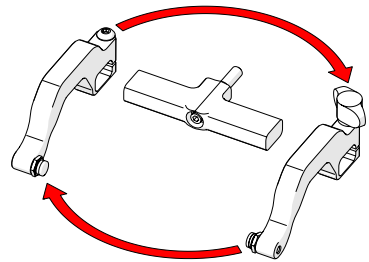

Fig. 57 - Reverse position around yoke

3. Loosen the arm clamp screw and the probe holder arm adjustment knob allowing the removal of the probe holder arms (Fig. 56).
4. Position the removed arms to the opposite sides of the yoke (Fig. 57).

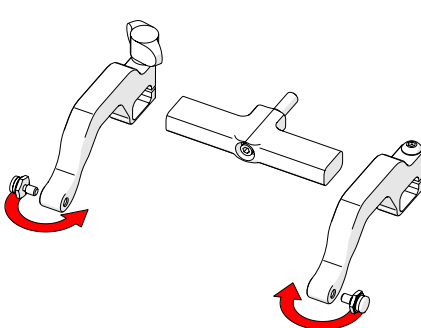

Fig. 58 - Position pivot buttons

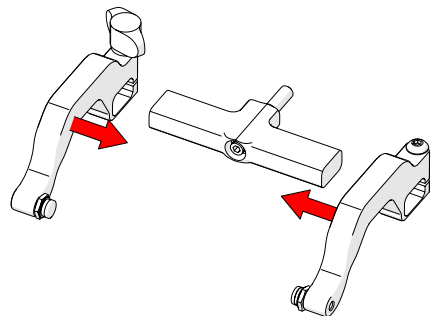

Fig. 59 - Remove outer arm

5. Position the pivot buttons to the inside of the probe holder arms (Fig. 58).
6. Place the probe holder arms on the yoke and tighten the arm clamp screw and probe holder adjustment knob (Fig. 59).
7. Use the supplied 3 mm driver to screw the yoke to the probe holder.

**TIP:** Position the yoke in the threaded hole closest to the frame bar when using a standard yoke length. Position the yoke in the threaded hole furthest from the frame bar when using a wide yoke length.

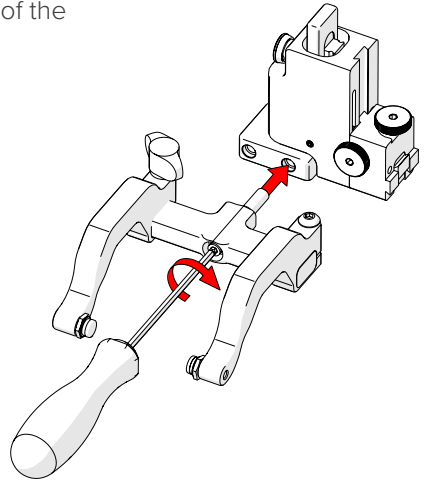

Fig. 60 - Screw into threaded hole

#### 5.6.4. Yoke Substitution

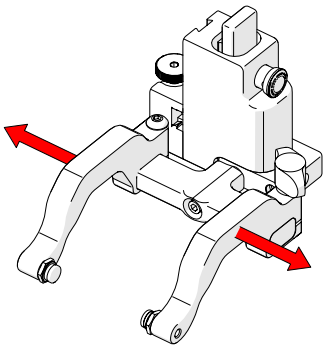

Fig. 62 - Remove probe holder arms

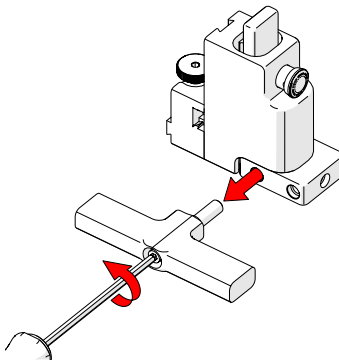

Fig. 63 - Remove yoke

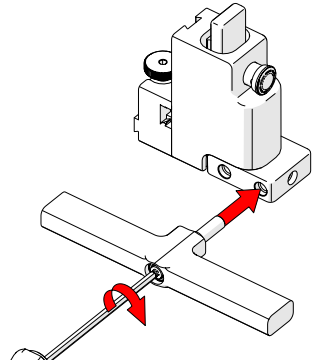

Fig. 64 - Screw into outer threaded hole

1. Loosen the arm clamp screw and the probe holder adjustment knob allowing the removal of the probe holder arms (Fig. 62).
2. Use the supplied 3 mm driver to unscrew the yoke (Fig. 63).
3. Choose an alternate size of yoke and screw the yoke to the outer probe holder hole (Fig. 64).
4. Place the probe holder arms on the yoke and tighten the arm clamp screw and probe holder adjustment screw (Fig. 61).

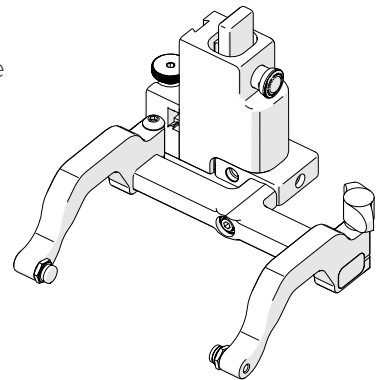

Fig. 61 - Alternate yoke size mounted

### 5.6.5. Probe Holder 90° Adjustment

1. Remove the yoke using the supplied 3 mm driver (*Fig. 54*).
2. Orient the yoke to the front of the probe holder and screw the yoke into the threaded hole provided (*Fig. 65*).

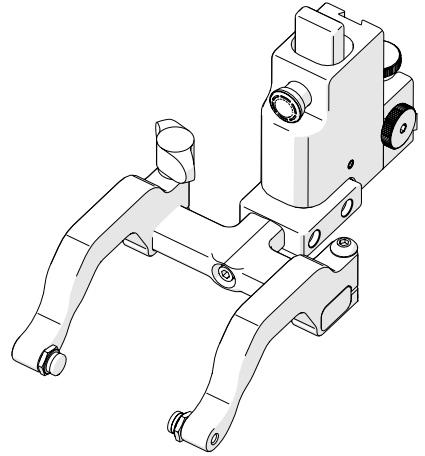

Fig. 65 - 90° probe holder positioning

### 5.7. Frame Bar with Ruler

Frame bars (*Fig. 66*) are used to mount probe holders, probe positioning systems and other accessories. The frame bar includes a ruler with 1 mm measurements.

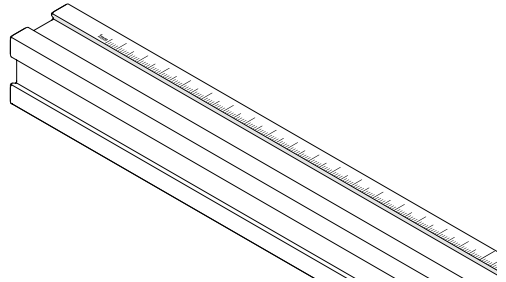

Fig. 66 - Frame bar

### 5.8. Pivot Buttons

Available in a variety of shapes and sizes, fitting various wedge dimensions.

Use the supplied 3/8 in wrench (*Fig. 18*) to remove and install pivot buttons (*Fig. 67*).

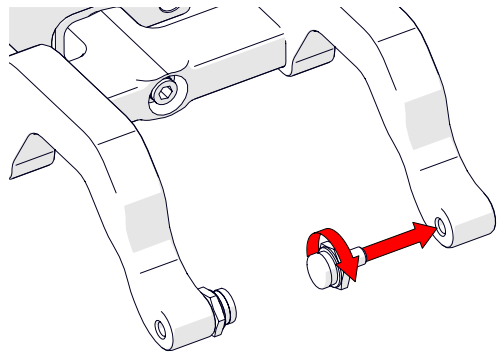

Fig. 67 - Pivot buttons

## 5.9. Index Encoder

The index encoder provides positional feedback perpendicular to the scan direction of travel.

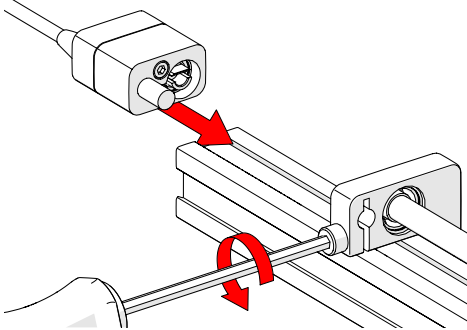

Fig. 68 - Loosen and slide post in place

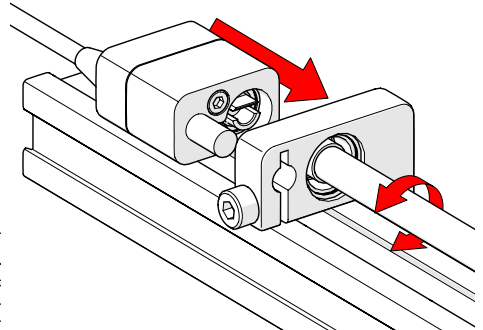

Fig. 69 - Align and mount post

1. To install the index encoder, loosen the clamp screw on the encoder with the supplied 3 mm hex driver (Fig. 68).
2. Insert the encoder post in the index encoder support bracket while aligning the leadscrew shaft with the encoder socket (Fig. 69).

**TIP:** You can rotate the leadscrew by hand to assist in the alignment of the encoder socket.

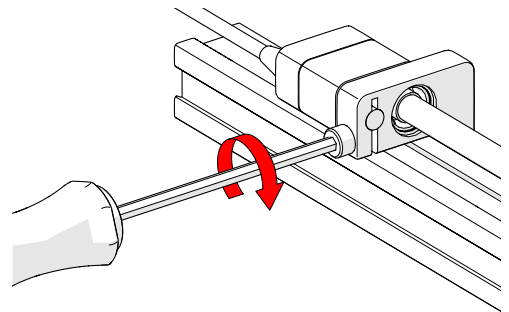

Fig. 70 - Tighten clamp screw

4. Plug the index encoder connector to the corrosion link (Fig. 71).

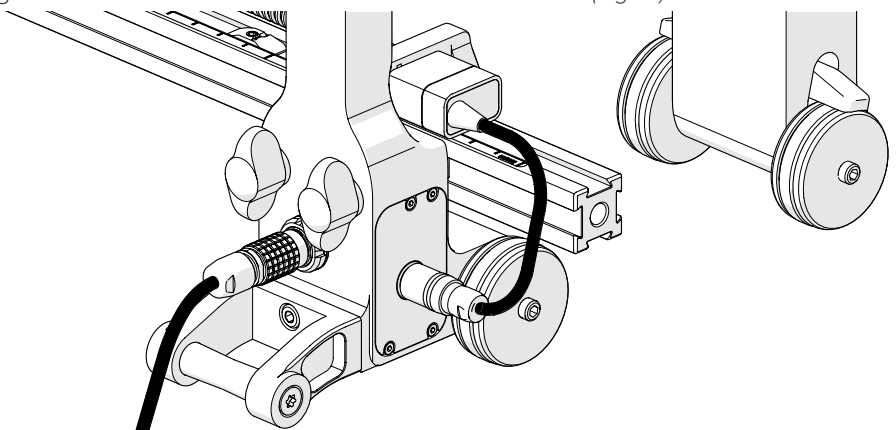

Fig. 71 - Connect index encoder to corrosion link

## 5.10. Cable Clips

Clips have been provided to assist with cable management. Pinch the clip and press it into the dovetail groove of the frame bar.

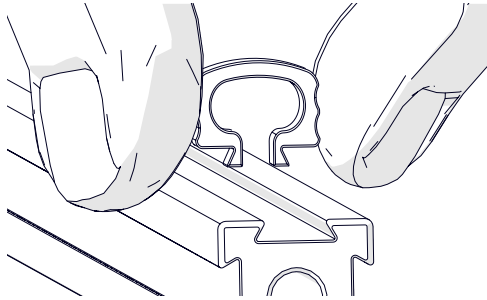

Fig. 72 - Pinch clip

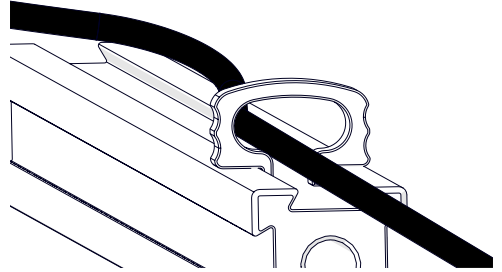

Fig. 73 - Route cables

## 5.11. Cable Management

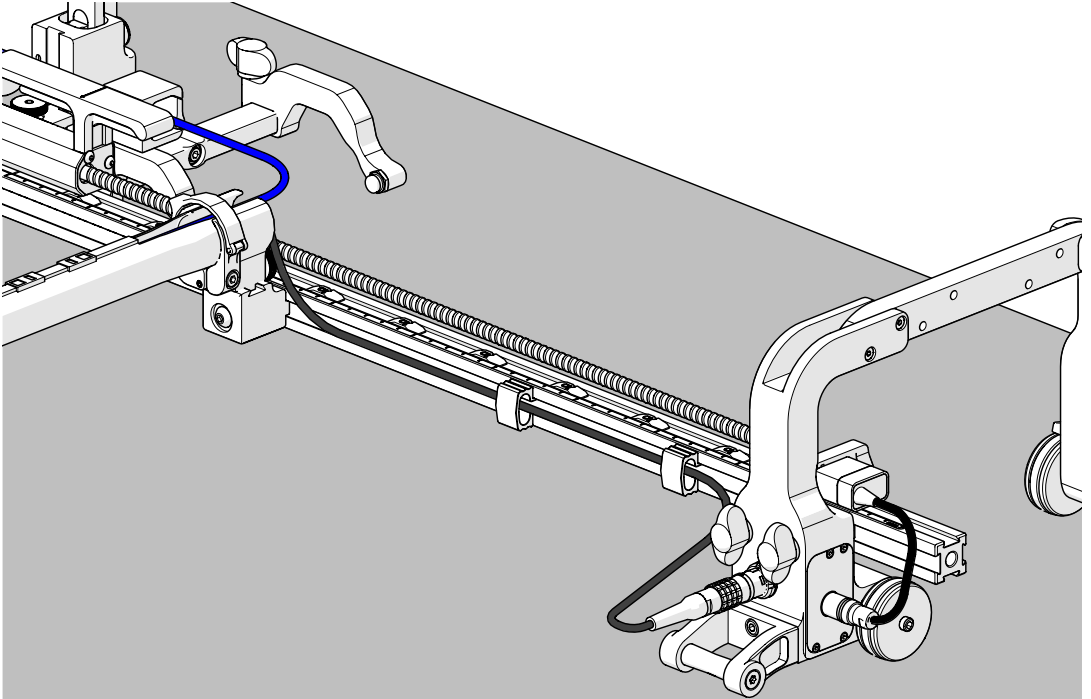

Fig. 74 - Cable management

**TIP:** When using cable management, ensure the dovetail link is placed 2<sup>nd</sup> in the chain behind the overhead adjustable link.

### 5.11.1. Cable Management Dovetail Mount

To attach the cable management, follow these steps:

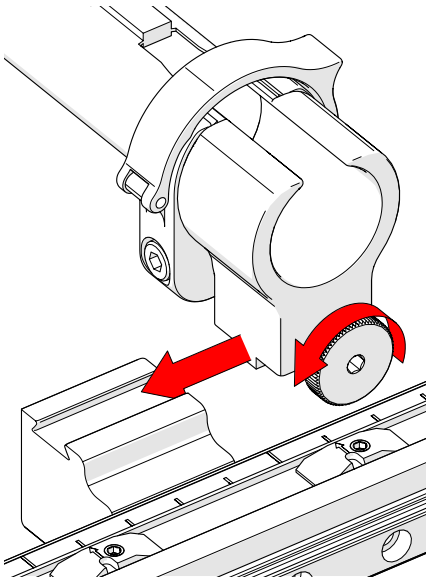

Fig. 75 - Loosen and slide on

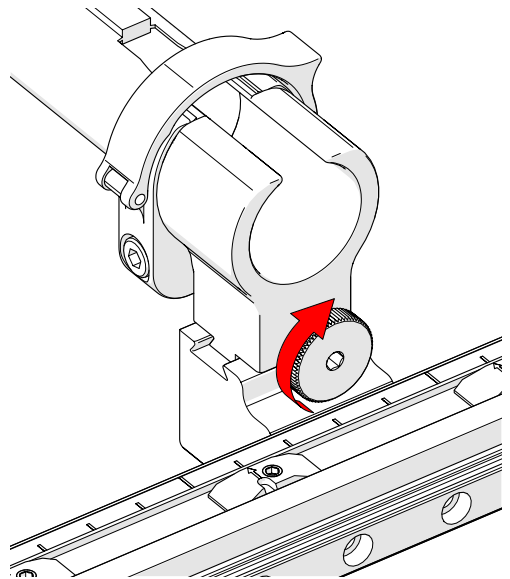

Fig. 76 - Tighten knob

1. Loosen the knob on the cable management dovetail mount. Slide the mount onto the dovetail link (Fig. 75).
2. Once centred on the dovetail link, tighten the cable management's dovetail mount knob (Fig. 76).

### 5.11.2. Cable Management Setup

The cable management is offered in a variety of lengths and provides a means of bundling and protecting cables and hoses that run to the scanner.

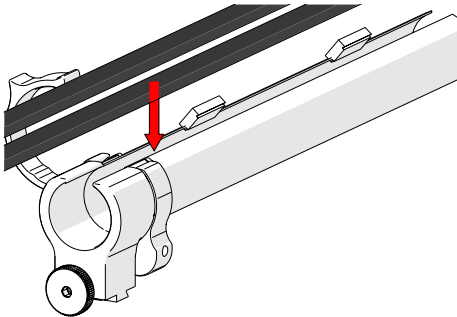

Fig. 77 - Insert cables and hoses

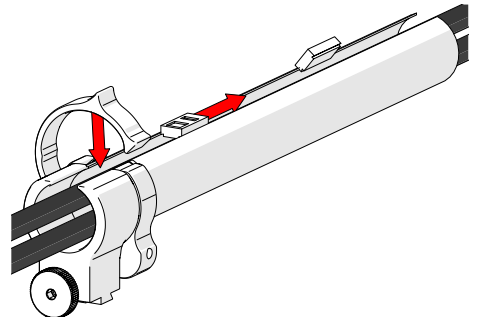

Fig. 78 - Zip up to close

1. Open the cable management and cable latch. Begin at the tube's dovetail mount and place the cabling in the tube (Fig. 77).

2. Follow the cable placement, zipping the tube closed and closing the cable management cable latch (Fig. 78).

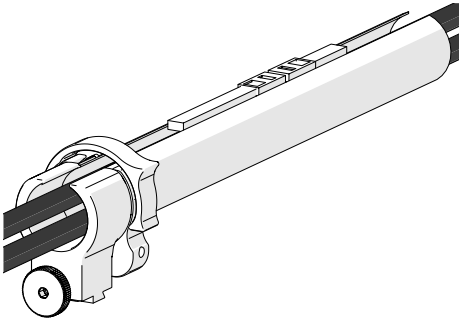

Fig. 79 - Zip opposite end

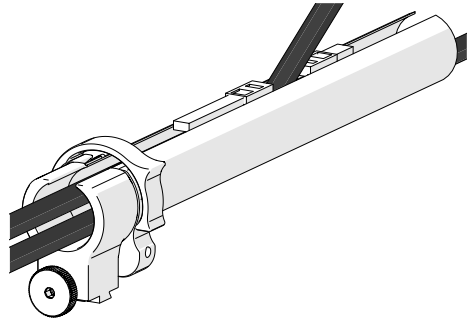

Fig. 80 - Flexibility

3. Once the cable is placed the entire length of the tube, bring the zipper from the tube's opposite end, meeting at any point in the middle (Fig. 79).
4. When necessary, the two zippers may be opened to allow cables to exit the tube anywhere between the ends (Fig. 80).

### 5.11.3. Clamp Setup

If the tube becomes disconnected from the cable management dovetail mount, follow these instructions to re-attach the tube and dovetail mount.

1. Loosen the clamp screw using the supplied 3 mm hex driver.
2. Slide the clamp around the tube first, then slide the tube around the outside of the cable management dovetail mount (Fig. 81). Align the zipper opening and the cable management dovetail mount opening.
3. Slide the clamp over the tube and cable management dovetail mount, pinching the tube in between (Fig. 82).
4. Tighten the clamp screw (Fig. 83).

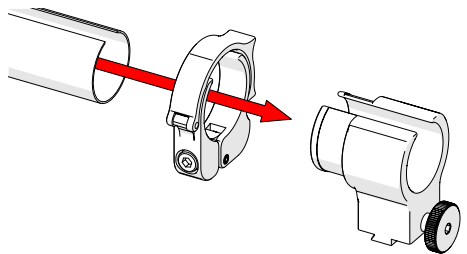

Fig. 81 - Slide tube around mount

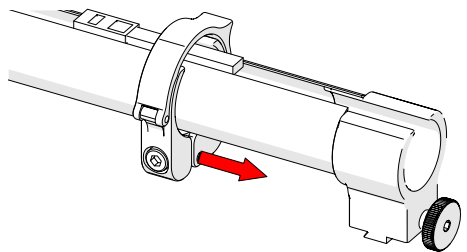

Fig. 82 - Slide clamp onto mount

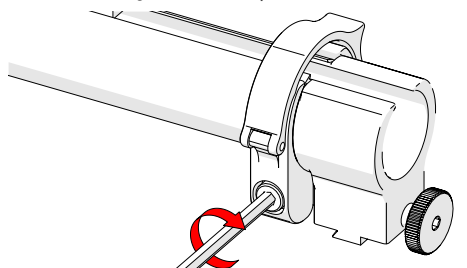

Fig. 83 - Tighten clamp screw

## 5.12. Preamp Bracket

Compatible with most standard preamps, use screws or the optional velcro straps to attach a preamp to the preamp bracket.

Intended Use

- ▶ The preamp bracket is intended to mount objects (e.g. preamps, splitters, etc.) that:
- ▶ have a maximum weight of 1.36 kg (3 lb)
- ▶ are attached to the with a lanyard or probe cables strong enough to prevent the object from falling
- ▶ have smooth edges so as not to cut the bracket's velcro strap

### 5.12.1. Mounting Preamp Bracket

The preamp bracket mounts to any dovetail groove.

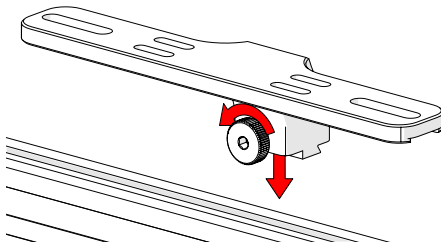

Fig. 84 - Loosen knob and mount to dovetail groove

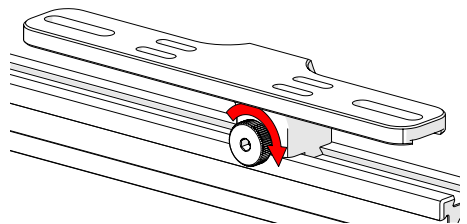

Fig. 85 - Tighten knob

1. Loosen the knob and align the dovetail nut with the dovetail groove (Fig. 84).
2. Tighten the knob to lock the preamp bracket in place (Fig. 85).

### 5.12.2. Attaching Preamp with Screws

Use the adjustable screw mounting channel on the bottom of the bracket to attach a preamp (screws not included).

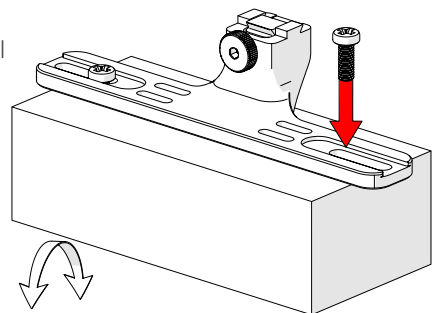

Fig. 86 - Attach preamp with screws

### 5.12.3. Attaching Preamp with Velcro Straps

To attach the preamp to the bracket using velcro straps, follow these steps:

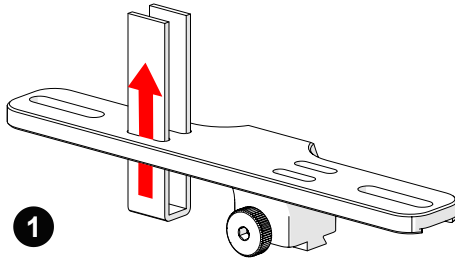

Fig. 87 - Insert velcro straps

1. Slide the velcro strap through the bracket's holes (Fig. 87).
2. Centre and place the preamp on the bracket, wrapping the velcro around the preamp (Fig. 88).
3. Secure the preamp to the bracket, attaching each side of the velcro (Fig. 89).

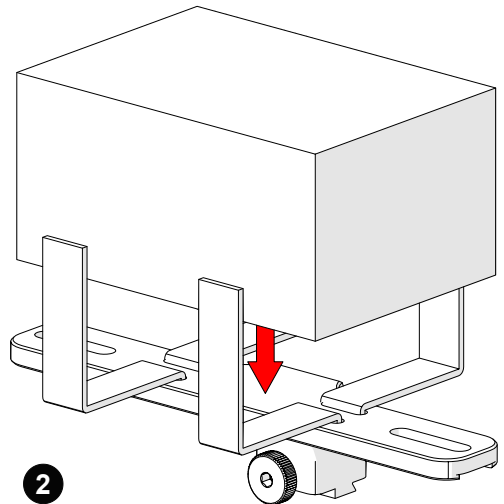

Fig. 88 - Place preamp and wrap velcro

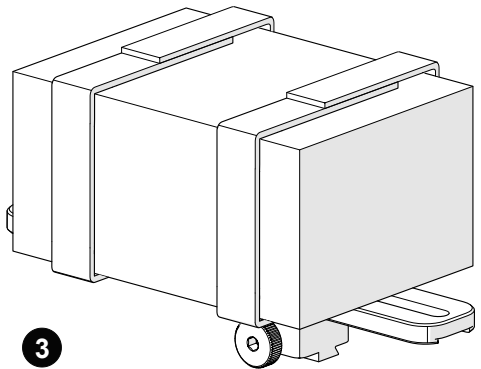

Fig. 89 - Mount bracket on a frame bar

# OPERATION

## 6.1. Setup of a STIX on a Scanning Surface

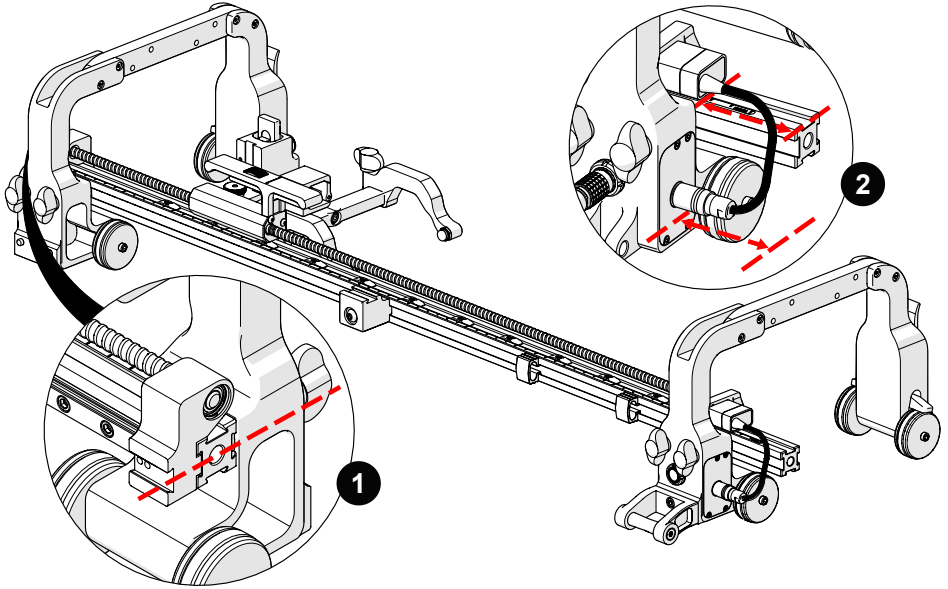

Fig. 90 - Frame bar offers protection for PPS encoder

1. Ensure the frame bar extends past the corrosion link (Fig. 90-2) on the encoder side. This will protect the index encoder connector. The non-encoded link can be flush with the frame bar (Fig. 90-1).

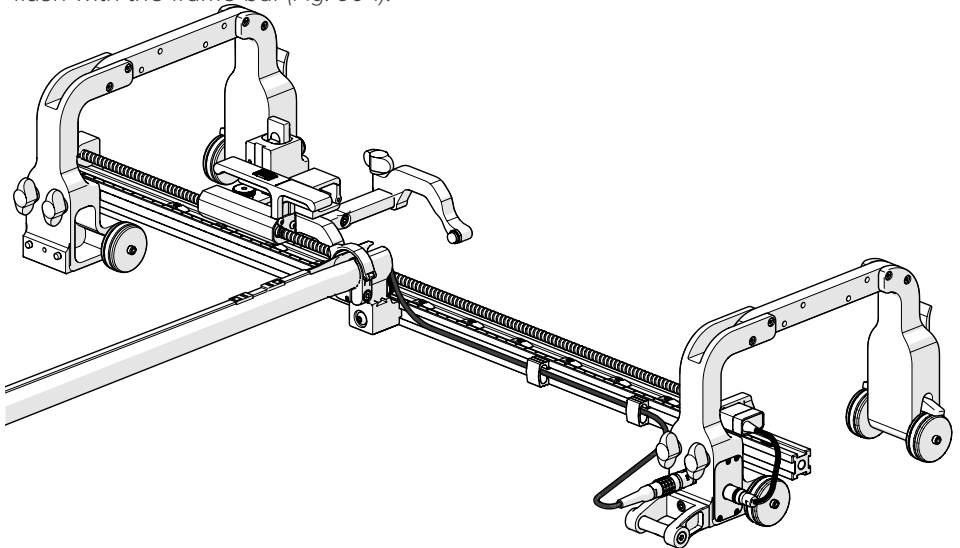

Fig. 91 - Route cabling

2. Plug in the encoder cable to the encoder connection (see *Encoder Connection on page 14*) and route the encoder cable through the cable management (see *Cable Management on page 26*) and cable clips (Fig. 91).

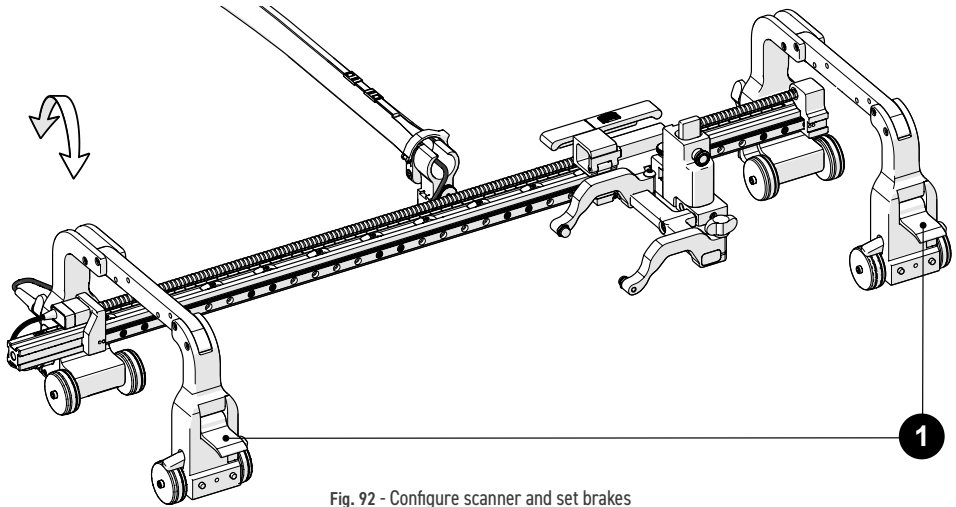

Fig. 92 - Configure scanner and set brakes

3. Install the wedge (see *Heavy Duty Vertical Probe Holder on page 20*) in the probe holder.
4. Ensure the brakes (Fig. 92-1) are activated (see *Brake on page 15*) on both corrosion links.

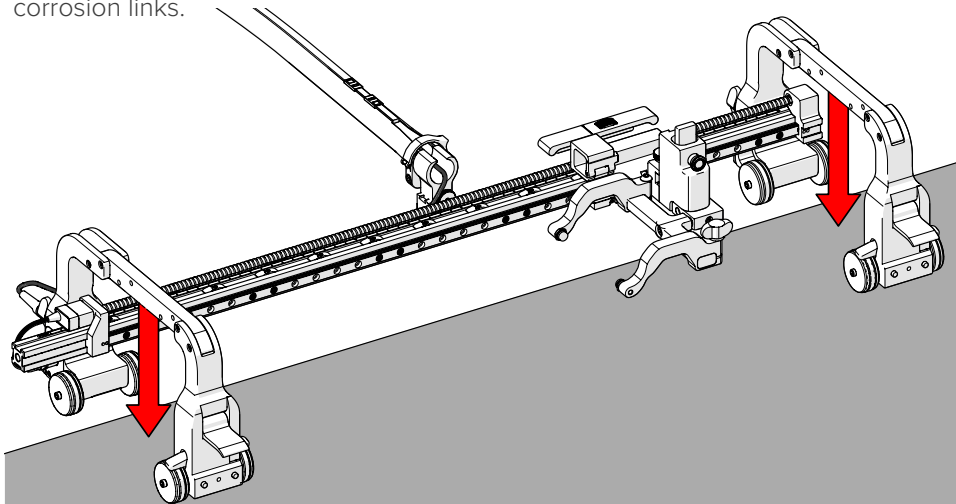

Fig. 93 - Place scanner on scan surface

5. Place the **STIX** on the scanning surface (Fig. 93).

**TIP:** Use caution when placing equipment on the scan surface. The magnetized wheels can cause the assembly to lurch towards the metal suddenly.

## MAINTENANCE

General cleaning of components is important to keep your system working well. All components that have no wiring or cables are completely waterproof. Components can be washed with warm water, dish soap and a medium bristle brush.

Before using the scanner, ensure all connectors are free of water and moisture.

**NOTE:** *All components with wiring, cables or electrical connections are splashproof. However, these components are **NOT** submersible.*

**NOTE:** *Never use strong solvents or abrasive materials to clean your scanner components.*

## TROUBLESHOOTING

Problem	Possible Cause	Solution
The encoder is not functioning.	The instrument is not set up correctly.	Refer to the instrument's documentation regarding proper setup.
	An issue with the encoder.	Contact Jireh Industries for repair ( <i>see Jireh Industries Ltd. on page 1</i> ).

### 8.1. Technical Support

For technical support, contact Jireh Industries (*see Jireh Industries Ltd. on page 1*).

## SERVICE AND REPAIR



**WARNING! DO NOT DISASSEMBLE.** No user-serviceable parts. Disassembling any of the components in this product, beyond the instructions in this user manual, could void the regulatory certifications and/or effect the safety of the product.

# SPARE PARTS

To order accessories or replacement parts for your **STIX** system.  
(contact Jireh Industries Ltd. on page 1)

**NOTE:** These drawings are for parts order. This is not a list of kit contents.

## 10.1. Corrosion Scanner

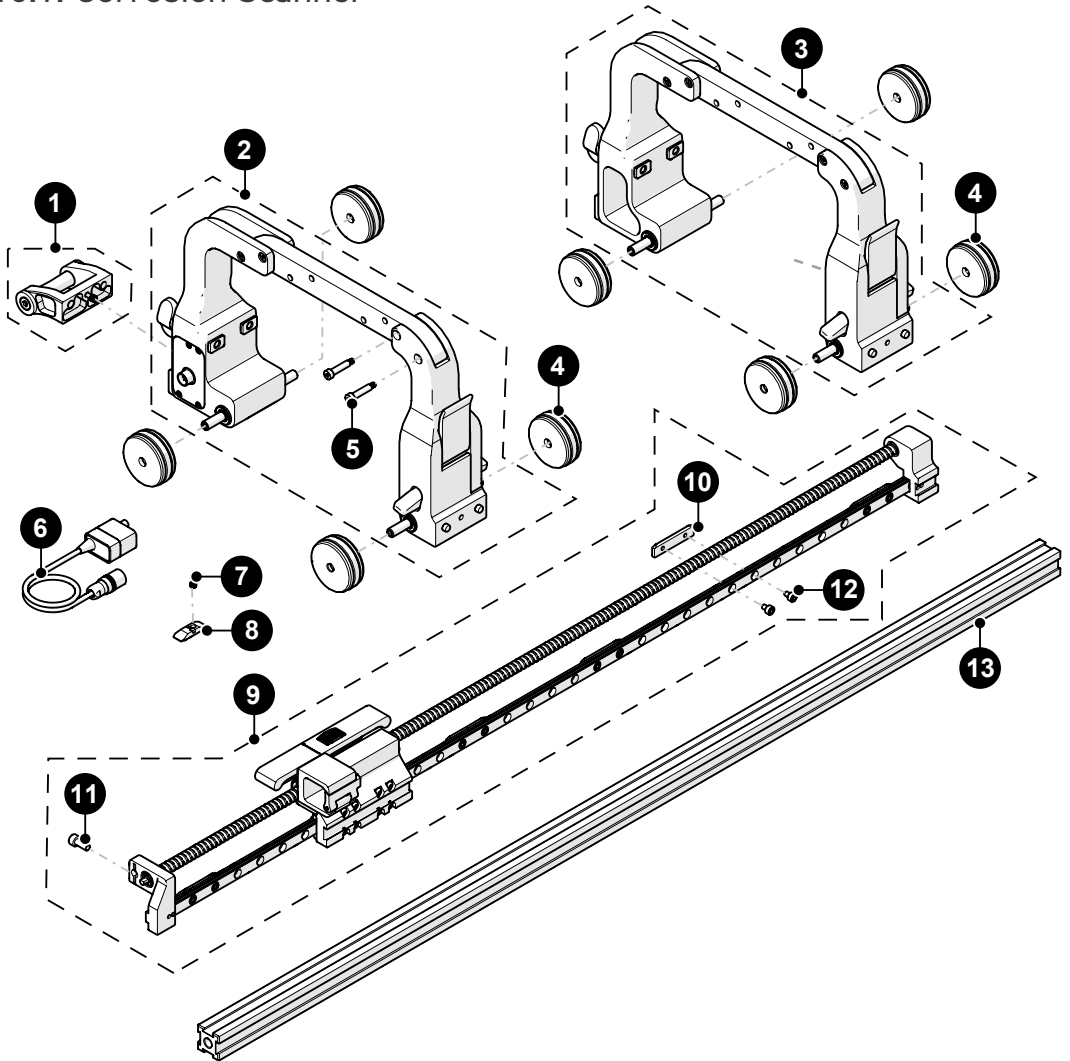

Fig. 94 - STIX corrosion scanner parts

BOM ID	Part #	Description
1	CES095	QuickLink tail
2	CES097-C	Corrosion link: extended
3	CES103-C	Non-encoded corrosion link: extended
4	BTS031	Magnetic wheel
5	MA252	SHSB, M3 x 0.5 x 4 mm, Ø 4 mm x 16 mm, SST
6	DKS009-S-0.4	PPS encoder
7	MA254	Screw, M4x3mm Flat PT. Hex Socket Set, SST
8	CE0116	Index nut
9	DKS010-58	Corrosion slider
10	DK0020	Dovetail nut
11	MD050-010	SHCS, M4x0.7 X 8 mm, SST
12	DK0019	SCREW, M3x4.5 SHCS, 3mm HEX
13	BG0090-75	Frame bar with ruler, 75 cm

## 10.2. Kit Contents

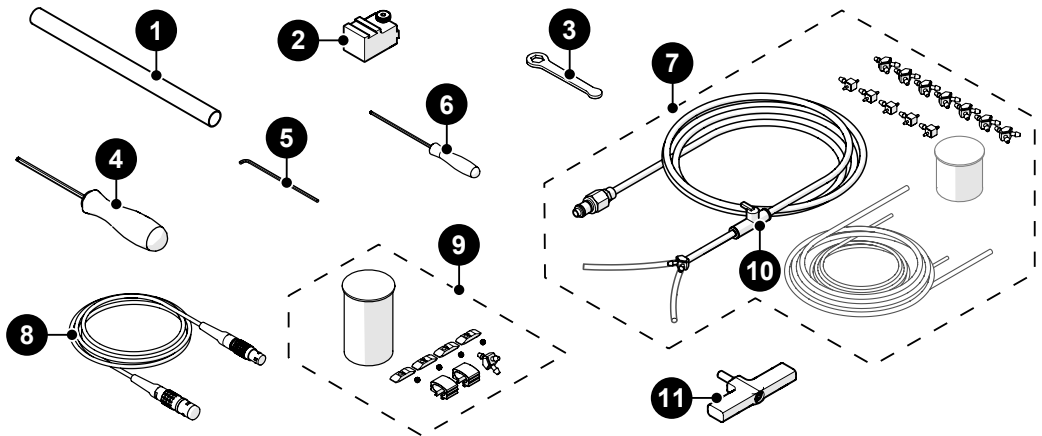

Fig. 95 - STIX kit components

BOM ID	Part #	Description
1	SP040	Cable sleeve
2	BGS068	Dovetail mount
3	EA476	3/8 in wrench
4	EA414	3 mm hex driver
5	CE0137	Short 2 mm hex wrench

6	EA476	2 mm hex driver
7	CMG007	Irrigation kit, 2-4 probe
8	UMA026-_-07.5	Encoder cable (see <i>Encoder Connector Type</i> )
9	CEG029	Corrosion scanner spare parts kit
10	LA034	Irrigation Shutoff Valve
11	See <i>Heavy Duty Yoke Style</i>	

### 10.2.1. STIX Corrosion Case

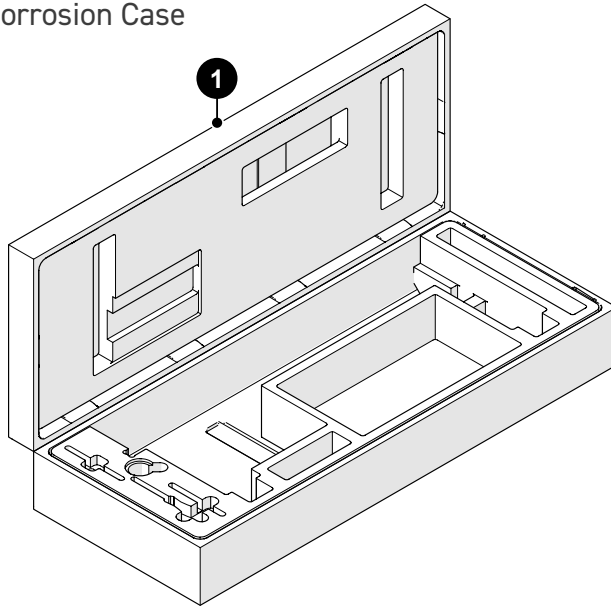

Fig. 96 - STIX corrosion case

Part #	BOM ID	Description
1	BGA017	STIX corrosion case

## 10.2.2. Encoder Connector Type

Connector Type	Company/Instrument	Connector Type	Company/Instrument
B	Olympus OmniScan MX Zetec Topaz	G	Sonotron Isonic 25xx
C	Olympus Focus LT Zetec Z-Scan Eddyfi Ectane 2	U	Sonatest Veo / Prisma
E	Olympus OmniScan SX/MX2/X3 M2M MANTIS/GEKKO LEMO	V	Pragma PAUT
F	TD ( <i>Technology Design</i> )	AD	Sonatest Veo / Prisma - Single Axis

**NOTE:** Additional encoder connector styles are available.  
(contact Jireh Industries Ltd. on page 1)

## 10.2.3. Cable Management

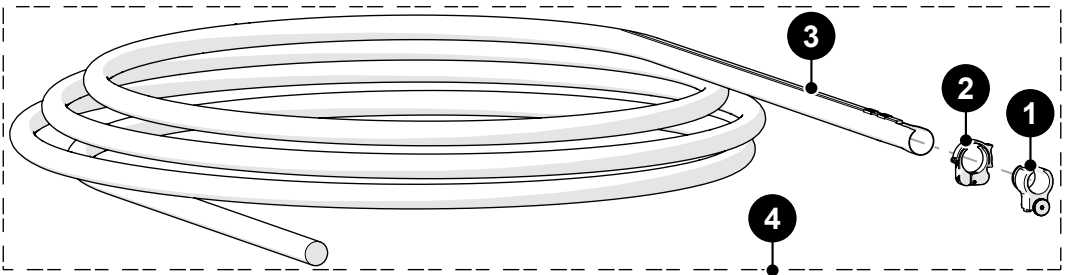

BOM ID	Part #	Description
1	CES067	Cable Management Mount, Dovetail Mount
2	CES066	Cable Management Clamp, Dovetail Mount
3		See <i>Cable Management Sleeving</i>
4	CES044- <u>    </u>	Cable Management: Dovetail ( <i>see cable management sleeving</i> )

Fig. 97 - Cable management

### 10.2.3.1 Cable Management Sleeving

Part #	Length
CX0226	7 m (22.9 ft)

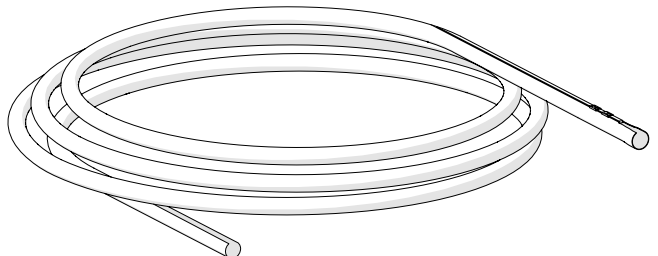
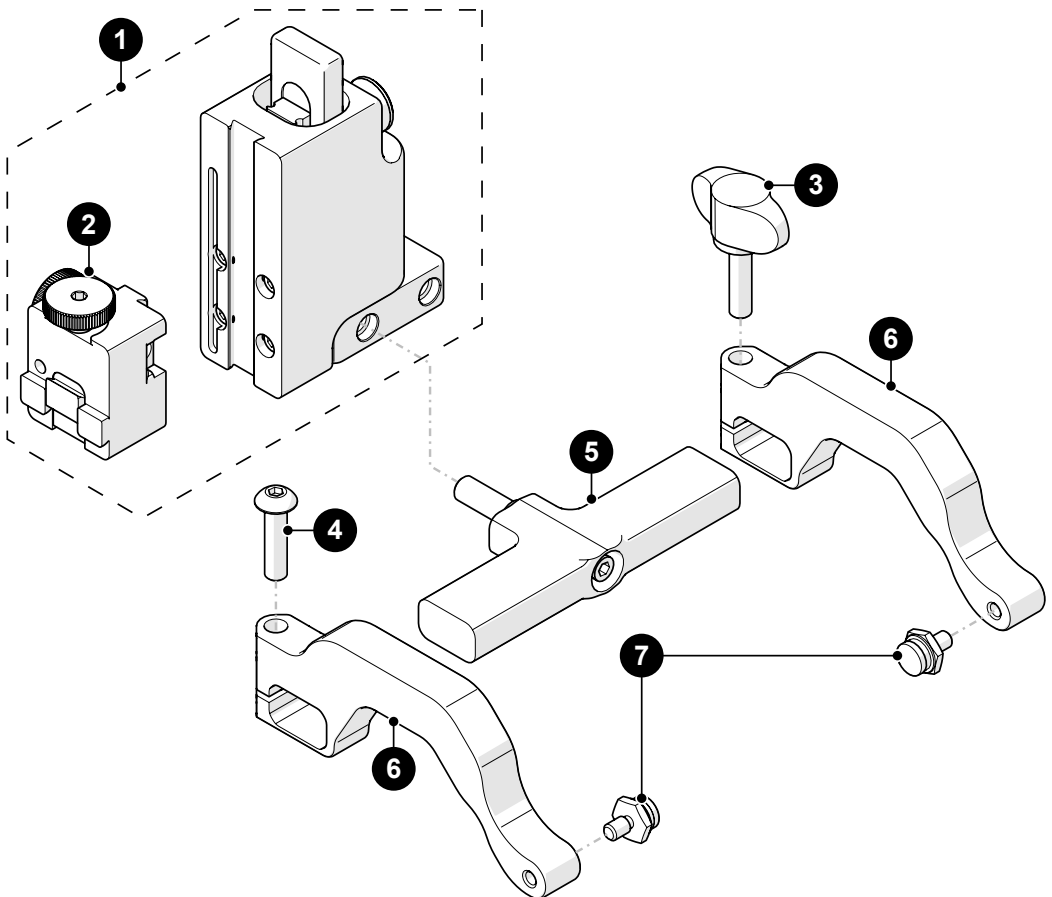

Fig. 98 - Cable management sleeving

## 10.3. Heavy Duty Vertical Probe Holder



BOM ID	Part #	Description
1	PHS049	Heavy Duty Probe Holder Subassembly
2	PHS085	Heavy Duty Probe Holder Mount
3	EA154	Probe Holder Arm Adjustment Knob
4	MD074-020	BHCS, M5 x 0.8 x 20 mm, SST
5		See Heavy Duty Yoke Style
6	PH0165	Heavy Duty Probe Holder Arm, Standard, Drop
7	PH0011- _	Pivot Button Style (See Pivot Button Style)

Fig. 99 - Heavy duty vertical probe holder

## 10.4. Probe Holder Components

### 10.4.1. Heavy Duty Yoke Style

Yoke Style	Part #	Length		Yoke Style	Part #	Length	
<b>S</b> Standard	PHS048	8.3 cm (3.26 in)		<b>W</b> Wide	PHS047	12.2 cm (4.79 in)	

Fig. 100 - Heavy duty probe holder yoke selection

### 10.4.2. Pivot Button Style











Pivot Hole Size	Wedge Type		Pivot Hole Size	Wedge Type	
<b>01</b> 8.0 mm (0.315 in)	Olympus PA		<b>02</b> 5.0 mm (0.197 in)	Olympus TOFD	
<b>03</b> 2.7 mm (0.106 in)	Sonatest DAAH PA		<b>04</b> 9.5 mm (0.375 in)	-	
<b>06</b> 3.0 mm (0.118 in)	-		<b>07</b> 2.3 mm (0.09 in)	-	
<b>08</b> Conical Head	-		<b>09</b> 5 mm (0.197 in) Internal	Zetec PA/TOFD	
<b>11</b> 3 mm (0.118 in) Internal	-		<b>14</b> 4 mm (0.157 in)	-	

Fig. 101 - Probe holder button selection

**NOTE:** Additional probe holder pivot button types are available. (contact Jireh Industries Ltd. on page 1)

## 10.5. Accessories

### 10.5.1. Magnetic Wheel Kit

Part #	Description
BTG014	Magnetic Wheel Kit

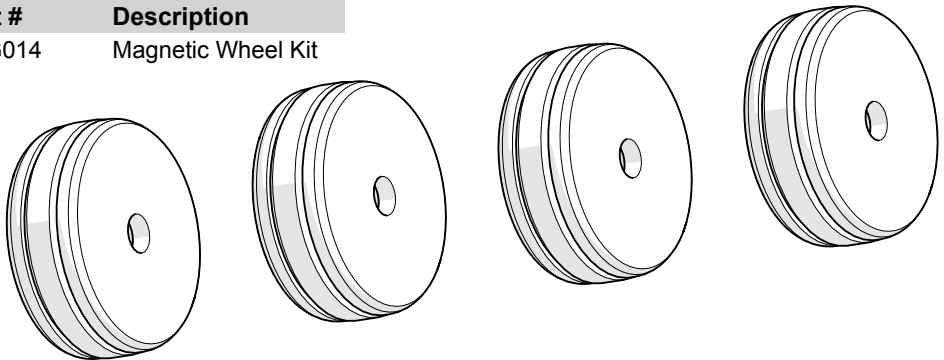

Fig. 102 - Magnetic wheel kit

### 10.5.2. Preamp Bracket

BOM ID	Part #	Description
1	CES029	Preamp Bracket
2	CES029-V	Preamp Bracket with Velcro

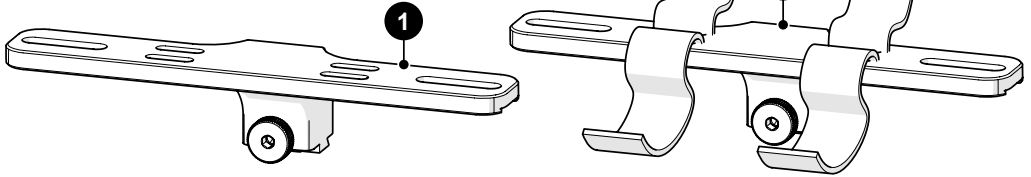

Fig. 103 - Preamp bracket

### 10.5.3. HydroFORM™ Cart

BOM ID	Part #	Description
1	PHS092	HydroFORM Cart - 2 <sup>nd</sup> Generation
2	CES054	Mini Wing Knob Assembly

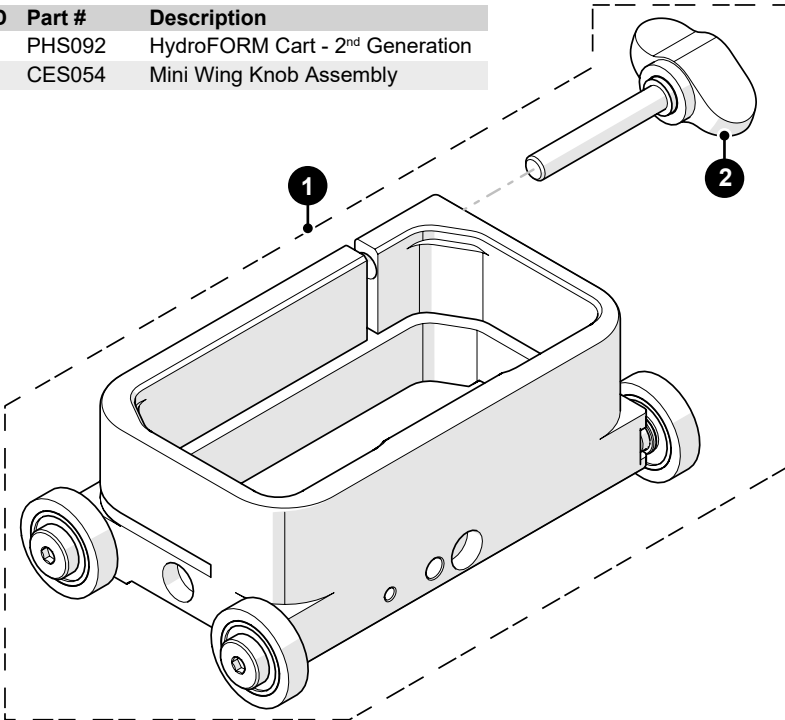

Fig. 104 - HydroFORM™ cart

## DISPOSAL

### WEEE Directive

In accordance with European Directive on Waste Electrical and Electronic Equipment (WEEE), this symbol indicates that the product must not be disposed of as unsorted municipal waste, but should be collected separately. Refer to Jireh Industries for return and/or collection systems available in your country.

## LIMITED WARRANTY

### WARRANTY COVERAGE

Jireh Industries warranty obligations are limited to the terms set forth below: Jireh Industries Ltd. (“Jireh”) warrants this hardware product against defects in materials and workmanship for a period of THREE (3) YEARS from the original date of purchase. If a defect exists, at its option Jireh will (1) repair the product at no charge, using new or refurbished replacement parts, (2) exchange the product with a product that is new or which has been manufactured from new or serviceable used parts and is at least functionally equivalent to the original product, or (3) refund the purchase price of the product. A replacement product/part assumes the remaining warranty of the original product or ninety (90) days from the date of replacement or repair, whichever provides longer coverage for you. When a product or part is exchanged, any replacement item becomes your property and the replaced item becomes Jireh’s property. When a refund is given, your product becomes Jireh’s property.

### OBTAINING WARRANTY SERVICE

To utilize Jireh’s warranty service you must ship the product, at your expense, to and from Jireh Industries. Before you deliver your product for warranty service you must phone Jireh and obtain an RMA number. This number will be used to process and track your product. Jireh is not responsible for any damage incurred during transit.

### EXCLUSIONS AND LIMITATIONS

This Limited Warranty applies only to hardware products manufactured by or for Jireh Industries. This warranty does not apply: (a) to damage caused by accident, abuse, misuse, misapplication, or non-Jireh products; (b) to damage caused by service (including upgrades and expansions) performed by anyone who is not a Jireh Authorized Service Provider; (c) to a product or a part that has been modified without the written permission of Jireh.

#### **Jireh Industries Ltd.**

53158 Range Road 224  
Ardrossan AB T8E 2K4  
Canada

Phone: 780-922-4534

[jireh.com](http://jireh.com)

All brands are trademarks or registered trademarks of their respective owners and third-party entities.

Changes or modifications to this unit or accessories not expressly approved by the party responsible for compliance could void the user's authority to operate the equipment.

All specifications are subject to change without notice.

© 2024-2025 Jireh Industries Ltd.



Jireh Industries Ltd.  
53158 Range Road 224  
Ardrossan, Alberta  
Canada  
T8E 2K4

780-922-4534

[jireh.com](http://jireh.com)