

■ ROTIX Cantilever



J JIREH

ROTIX carrying two phased array probes

WEIGHT AND DIMENSIONS

Cart Weight

- 0.67 kg (1.48 lb)

Cart Dimensions

- Height: 9.8 cm (3.9 in)
- Width: 8.1 cm (3.2 in)
- Depth: 15.3 cm (6 in)

FEATURES

ROTIX Cart

- The ROTIX cart's urethane wheels glide smoothly over rough surfaces with a handle that offers convenience and comfort during operation. The cart has been designed with an integrated positional encoder with a custom output, compatible with many instruments.

Adjustable QuickLinks

- Using QuickLinks and with an adjustable QuickLink buckle, pipes and tubes ranging from 7.6 - 96.5 cm (3 - 38 in) in diameter can be effortlessly scanned.

Probe Positioning System (optional)

- This easy-to-use accessory allows the simple positioning of 2 or 4 probes during weld inspection. It allows you to easily control probe center spacing and adjust probe positioning without removing the scanner from a pipe.

Slip Joint Probe Holders

- These outstanding low-profile probe holders are compatible with most standard probes. Their user-friendly design allows for easy probe adjustment.

Modular Design

- A notable feature of ROTIX components is their versatility, as many can be repurposed and converted to different ROTIX configurations. Additionally, the wheels can be replaced with magnetic wheels, which transforms the system into a MICROBE configuration for ferrous inspection purposes.

Cable Management

- To provide added convenience, the cart body features a convenient clip that can direct cables and hoses to the sleeving solution for organizing and protecting cables/hoses.

SPECIFICATIONS

Circumferential Pipe Range

- 7.6 - 96.5 cm (3 - 38 in)

Radial Clearance on Minimum Diameter

- 10.2 cm (4 in)

Encoder Resolution

- 66.0 counts/mm (1676.3 counts/inch)

Probe Holding Capacity

- Two phased array wedges
- Two TOFD wedges

Umbilical length

- 5 m (16.4 ft)¹

Inspection Surface

- Ferrous or non-ferrous materials

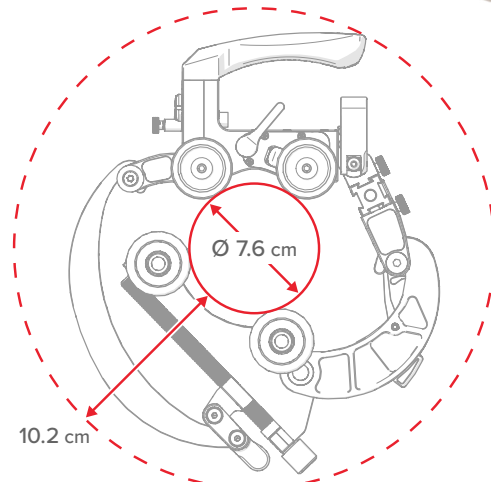

ENVIRONMENTAL SPECIFICATIONS

Operating Environment

- -20°C (-4°F) to 50°C (122°F)

Environmental Sealing

- Dust-tight, watertight (not submersible)



Standard QuickLinks and the adjustable QuickLink Buckle



A ROTIX single probe configuration

1. Custom umbilical lengths are available. Technical specifications subject to change.