



STIX

BG0088 Rev 05.7

Manual Magnetic TOFD Scanner

SAFETY WARNINGS / PRECAUTIONS

KEEP THIS MANUAL – DO NOT LOSE

THIS MANUAL IS PART OF THE STIX AND MUST BE RETAINED FOR THE LIFE OF THE PRODUCT. PASS ON TO SUBSEQUENT OWNERS.

Ensure any amendments are incorporated with this document.



WARNING! The **STIX** is designed for a specific use. Using the **STIX** outside of its intended use could cause damage to the product. Read and understand this manual before using.



WARNING! Can be harmful to pacemaker and ICD wearers. Stay at least 25 cm (10 in) away.



WARNING! Do **NOT** operate scanner in an explosive environment. Do **NOT** operate scanner in the presence of volatile substances.



WARNING! DO NOT DISASSEMBLE. No user-serviceable parts. Disassembling any of the components in this product, beyond the instructions in this user manual, could void the regulatory certifications and/or effect the safety of the product.



The WEEE symbol indicates that the product must not be disposed of as unsorted municipal waste, but should be collected separately.

(see “Disposal” on page 34)

TABLE OF CONTENTS

1	Identification	1
	1.1. Product Brand	1
	1.2. Manufacturer	1
2	Product Specifications	2
	2.1. Base STIX Specifications	2
	2.1.1. Intended Use	2
	2.1.1.1 Operating Limits	2
	2.1.1.2 Operating Environment	2
	2.1.2. Dimensions and Weight	3
	2.1.3. Environmental Sealing.....	3
	2.1.4. Performance Specifications	3
3	Definitions	4
	3.1. Definitions of Symbols	4
	3.2. Definitions of Terms	4
4	System Components	5
	4.1. Base System Components	5
	4.1.1. STIX Frame	5
	4.1.2. Spring-Loaded Probe Holder	5
	4.1.3. Frame Bar	5
	4.1.4. Spring-Loaded Encoder	6
	4.1.5. Magnetic Wheel	6
	4.1.6. Irrigation Kit	6
	4.1.7. Tools	6
	4.1.8. Case	6
	4.2. Compatible Components	7
	4.2.1. Cable Management	7
	4.2.2. Encoder Adapter	7
	4.2.3. Preamp Bracket	7

	4.3. Tools	8
5	Preparation For Use	9
	5.1. Configurations	9
	5.1.1. Two Probe TOFD	9
	5.1.2. Two Probe TOFD Cantilever	9
	5.2. Handle	10
	5.2.1. Sleeving	11
	5.3. Wheel Block	12
	5.3.1. Wheel Installation	12
	5.3.2. Wheel Removal	13
	5.3.3. Ratchet Lever	13
	5.4. Frame Bar	13
	5.5. Spring-Loaded Encoder	14
	5.6. Spring-Loaded Probe Holder	15
	5.6.1. Probe Holder Setup	15
	5.6.2. Pivot Buttons	17
	5.7. Magnetic Wheel Kit	17
	5.8. Preamp Bracket	18
	5.8.1. Mounting Preamp Bracket	18
	5.8.2. Attaching Preamp with Screws	19
	5.8.3. Attaching Preamp with Velcro Strap	19
6	Operation	20
	6.1. STIX setup on a scan surface	20
7	Maintenance	23
8	Troubleshooting	24
	8.1. Technical Support	24
9	Service and Repair	25
10	Spare Parts	26
	10.1. Scanner	26
	10.2. Kit Components	27
	10.2.1. Encoder Connector Type	28

10.3. Accessories.....	28
10.3.1. Magnetic Wheel Kit	28
10.3.2. Preamp Bracket	29
10.3.3. Cable Management	29
10.3.3.1 Cable Management Sleeving	29
10.4. Probe Holders	30
10.4.1. Slip Joint Probe Holder Parts	30
10.4.2. Vertical Probe Holder Parts	31
10.5. Probe Holder Components	32
10.5.1. Spring-Loaded Arm Style	32
10.5.2. Slip Joint and Vertical Probe Holder Arm Style	32
10.5.3. Slip Joint and Vertical Probe Holder Yoke Style	32
10.5.4. Swing Arm Style	32
10.5.5. Pivot Button Style	33
10.6. Variable Components	33
10.6.1. Frame Bars	33

11 Disposal	34
--------------------------	-----------

12 Limited Warranty	35
----------------------------------	-----------

IDENTIFICATION

1.1. Product Brand

The **STIX** is a manually operated scanner with a spring-loaded encoder and magnetic wheels. It is designed to translate TOFD probes around ferrous piping.

1.2. Manufacturer

Distributor:

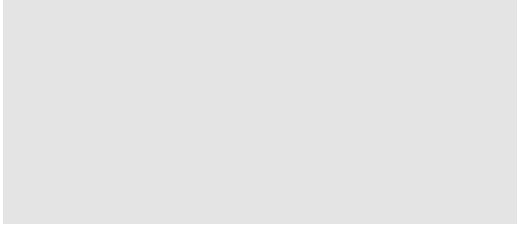

Manufacturer:

Jireh Industries Ltd.
53158 Range Road 224
Ardrossan, Alberta, Canada
T8E 2K4
Phone: 780.922.4534
jireh.com

PRODUCT SPECIFICATIONS

2.1. Base STIX Specifications

2.1.1. Intended Use

The **STIX** is a manual magnetic scanner with a spring-loaded encoder and magnetic wheels. It is designed to translate two TOFD probes around ferrous piping and vessels.

2.1.1.1 Operating Limits

Category	Parameter	Specification
Circumferential configuration	Minimum pipe/tube ID	10.2 cm (4 in)
	Maximum pipe/tube ID	Flat
Circumferential configuration	minimum pipe/tube OD	Flat
	Maximum pipe/tube OD	152.4 cm (60 in)
Scanner	Radial scanner clearance	13.1 cm (5.1 in)

2.1.1.2 Operating Environment

The **STIX** is designed for use in industrial environments that are between -20°C (-4°F) and 50°C (122°F).

2.1.2. Dimensions and Weight

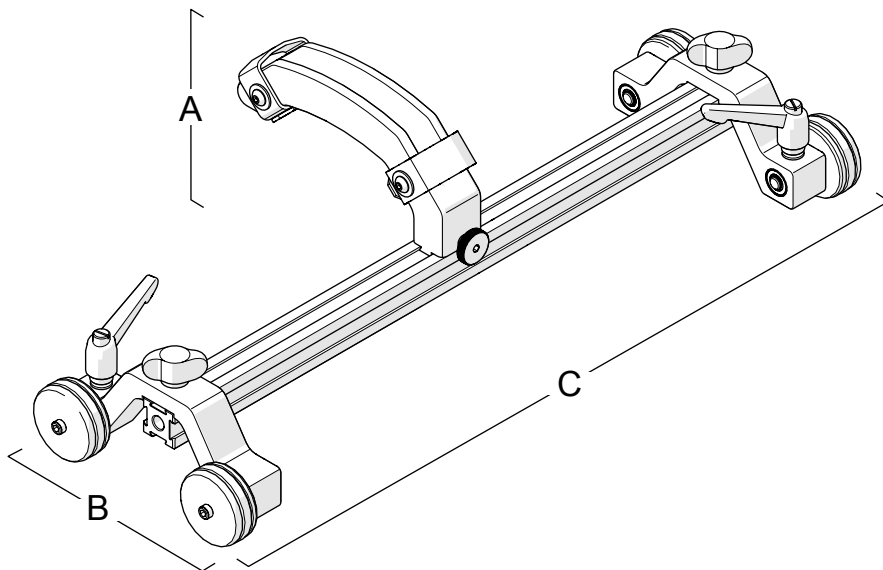

Fig. 1 - Frame dimensions

A:	10.5 cm	4.1 in
B:	17.5 cm	6.9 in
C:	45.4 cm	17.9 in
Frame weight	1.19 kg	2.6 lb
Encoder cable length (<i>standard kit</i>)	5 m	16.4 ft

2.1.3. Environmental Sealing

Watertight (*submersible*) (*contact Jireh Industries Ltd. on page 1 for details*).

2.1.4. Performance Specifications

Encoder resolution:	9.05 counts/mm	230.0 counts/inch
---------------------	----------------	-------------------

DEFINITIONS

3.1. Definitions of Symbols



Instructions to 'look here' or to 'see this part.'

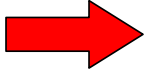

Denotes movement. Instructing users to act in a specified direction.

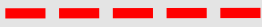

Indicates alignment axis and can also indicate insertion or movement of parts.



Alerts user that the view has changed to a reverse angle.

3.2. Definitions of Terms

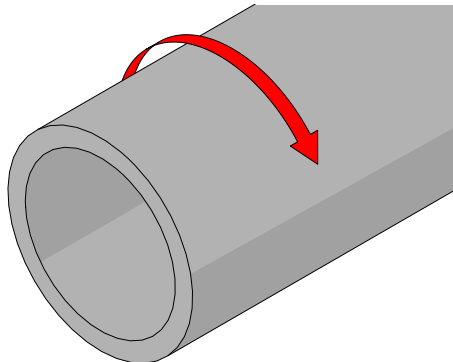

Fig. 2 - Circumferential scanning

Circumferential

Direction of scan travel is around the circumference of the pipe/tube (Fig. 2).

SYSTEM COMPONENTS

4.1. Base System Components

4.1.1. STIX Frame BGA008-

The STIX frame is the backbone of the scanner, providing a mounting point for probe holders, encoders and accessories. The magnetic wheels attach the scanner to ferrous materials.

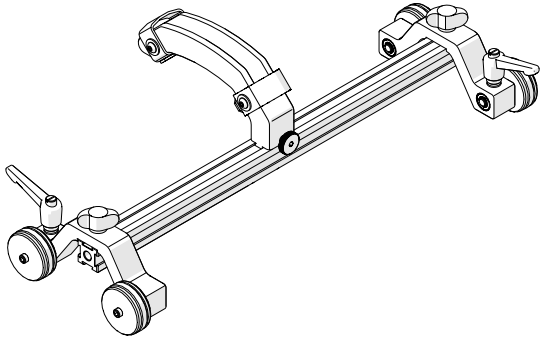

Fig. 3 - STIX frame

4.1.2. Spring-Loaded Probe Holder PHS033-

A simplified probe holder provides adjustment and quick setup of probe centre spacing (PCS). The spring-loaded probe holder can hold many different types of probes and wedges.

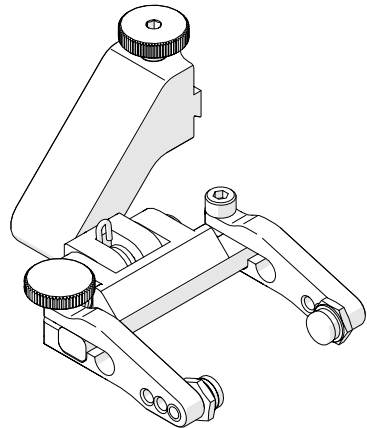

Fig. 4 - Spring-loaded probe holder

4.1.3. Frame Bar BG0038-

Frame bars use dovetail grooves to attach probe holders and accessories. Available in various lengths.

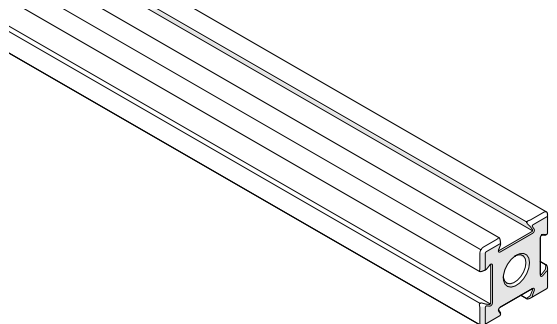

Fig. 5 - Frame bar

4.1.4. Spring-Loaded Encoder BGS053-

The spring-loaded encoder mounts to any standard frame bar and provides encoded positional feedback to the user's instrument.

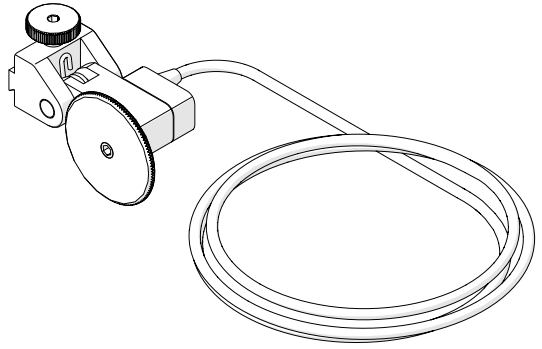

Fig. 6 - Spring-loaded encoder

4.1.5. Magnetic Wheel BTS031

Magnetic wheels allow the scanner to adhere to ferrous materials. Magnetic wheels can be added to the system to increase magnetic attraction.

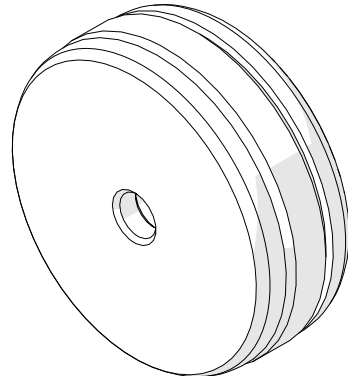

Fig. 7 - Magnetic wheel

4.1.6. Irrigation Kit CMG007

The irrigation kit provides a variety of hoses, fittings, connectors, and splitters commonly used during non-destructive inspection.

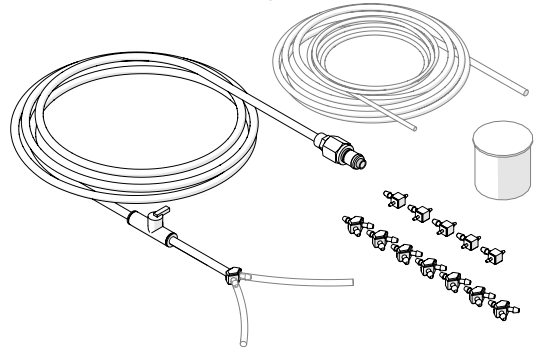

Fig. 8 - Irrigation kit

4.1.7. Tools

Several tools are included for various scanners and accessory adjustments.

4.1.8. Case

The system is provided with a rugged carrying case.

4.2. Compatible Components

4.2.1. Cable Management CES044-

The cable management provides a means of protecting and organizing cables, tubes and hoses.

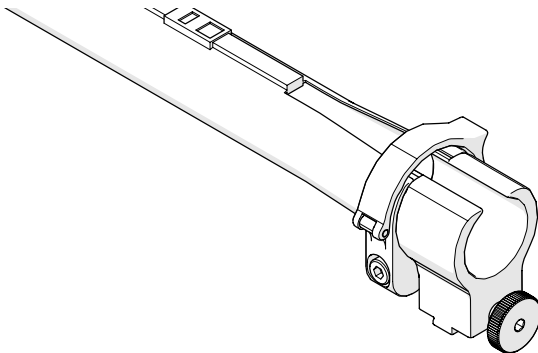

Fig. 9 - Cable management

4.2.2. Encoder Adapter UMA010-

Adapt a scanner's existing encoder connector to a different encoder style.

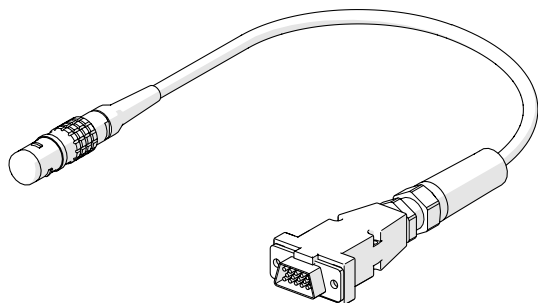

Fig. 10 - Encoder adapter

4.2.3. Preamp Bracket CES029-

A bracket that mounts to a scanner to hold various preamps.

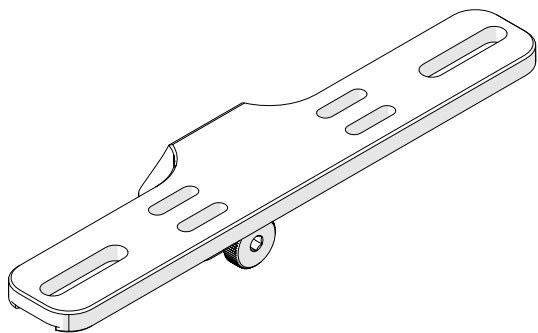

Fig. 11 - Preamp bracket

4.3. Tools

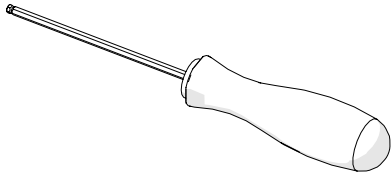

Fig. 12 - 3 mm hex driver

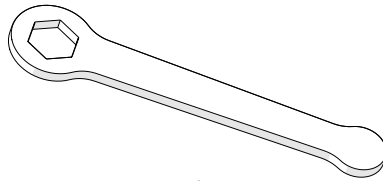

Fig. 13 - 3/8 in wrench

The 3 mm hex driver (*Fig. 12*) is sufficient for all typical operations and adjustments of the **STIX**.

The 3/8 in wrench (*Fig. 13*) removes and installs pivot buttons on the probe holders..

PREPARATION FOR USE

5.1. Configurations

5.1.1. Two Probe TOFD

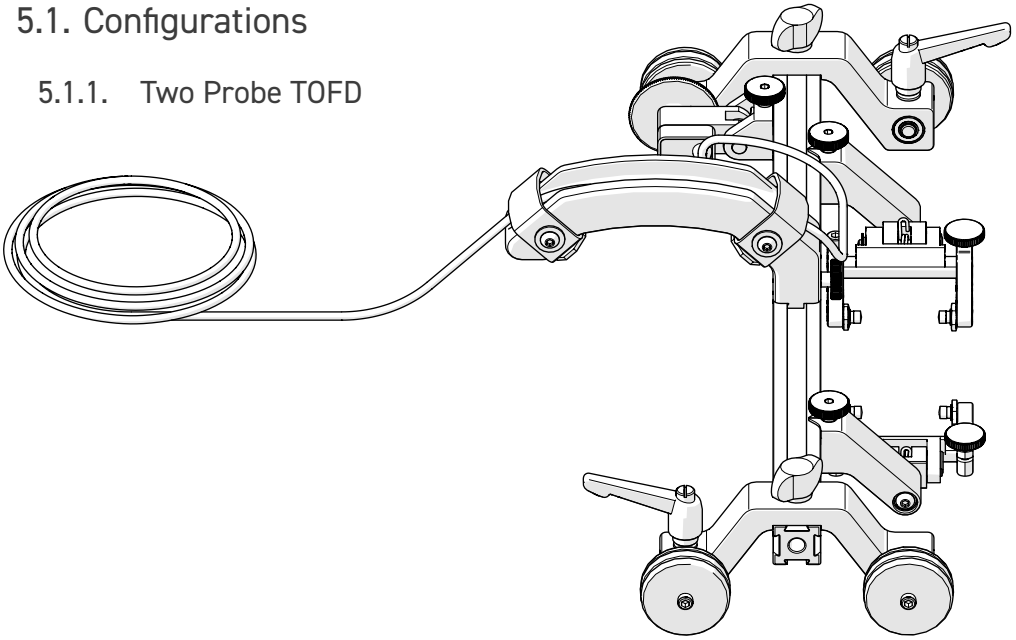

Fig. 14 - Two probe TOFD configuration

5.1.2. Two Probe TOFD Cantilever

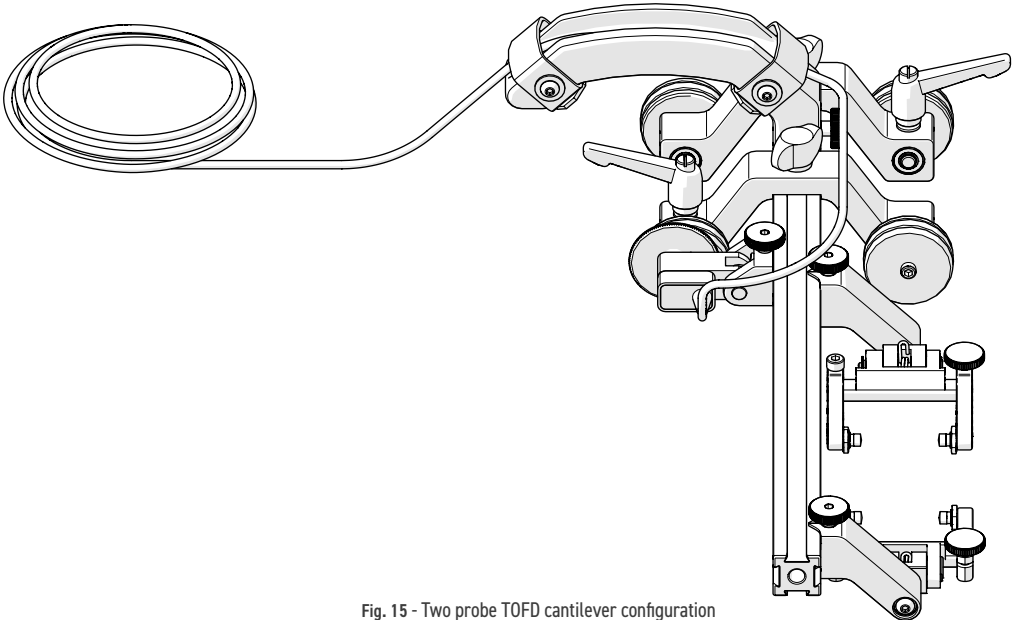

Fig. 15 - Two probe TOFD cantilever configuration

5.2. Handle

Used to operate the scanner as well as provide a means of cable management. To install and set the handle, follow these steps:

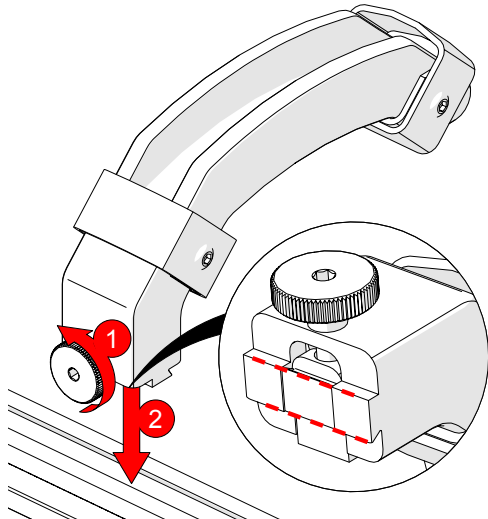

Fig. 16 - Attach handle to frame bar

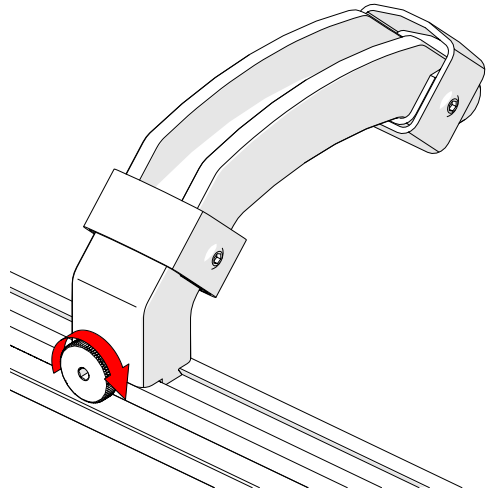

Fig. 17 - Tighten handle knob

1. Loosen the handle's knob and mount it to a frame bar (Fig. 16).
2. Tighten the handle knob to fasten the handle to the frame bar (Fig. 17).

TIP: Slightly loosen the handle knob and slide the handle along the frame bar for alternate placement when required.

3. Open the velcro straps and place cables and hoses in the handle (Fig. 18). Reattach the velcro straps to secure the cables and hoses within the handle.

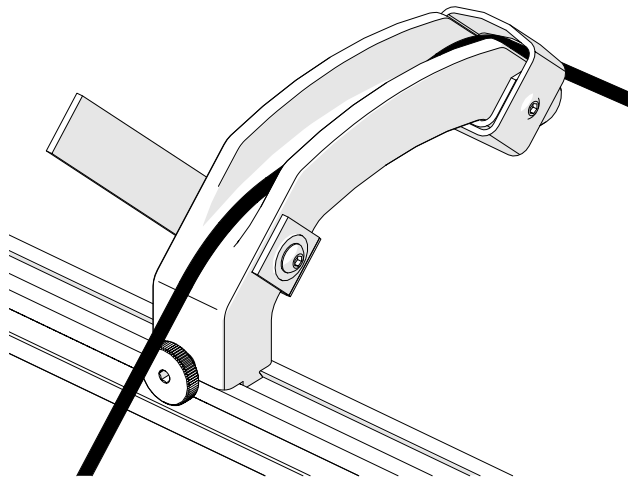

Fig. 18 - Handle provides cable management

5.2.1. Sleeving

The sleeving is provided to protect cables and tubes and act as a means of cable management. To place the tubes and cables in the sleeving with the loom installation tool, follow these steps:

1. Rout the cable/tubes through the loom installation tool and clip shut (*Fig. 19*).

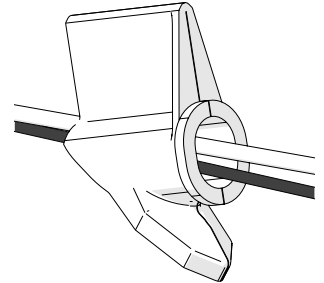

Fig. 19 - Loom installation tool

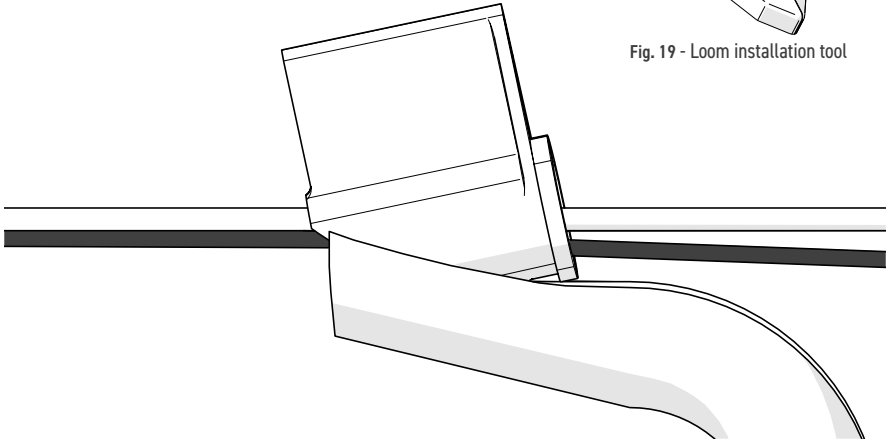

Fig. 20 - Wrap sleeving around cables and tubes using loom installation tool

2. Begin at one end of the sleeving; use the loom's shoe to open the sleeving and begin wrapping the open sleeve around the cables (*Fig. 20*).

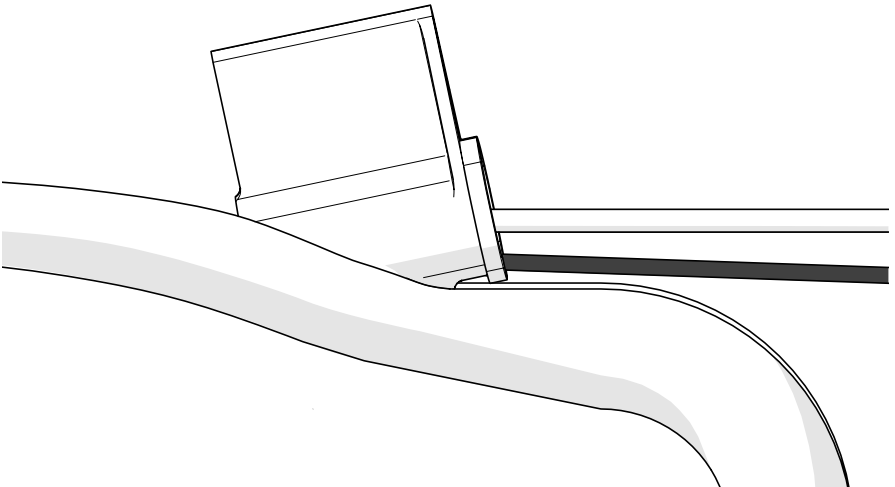

Fig. 21 - Wrap sleeving around cables and tubes using loom installation tool

3. Continue sliding the loom installation tool inside the sleeving, placing the cables and tubes safely inside the sleeving (*Fig. 21*).

5.3. Wheel Block

The wheel block provides stability and braking to the **STIX** system.

The ratchet lever on the wheel block operates a brake (see *Ratchet Lever* on page 13).

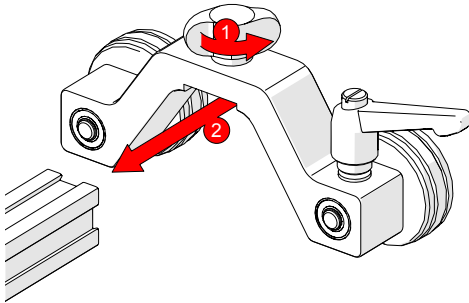

Fig. 22 - Attach to frame bar

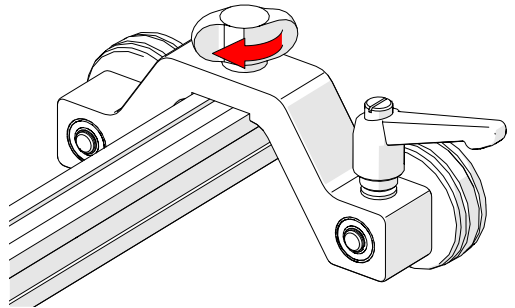

Fig. 23 - Tighten wing knob

Attach a wheel block by loosening the black wing knob and sliding the wheel block's dovetail nut onto a frame bar (Fig. 22). Tighten the black wing knob (Fig. 23).

5.3.1. Wheel Installation



WARNING! MAGNETIC MATERIAL. The magnetic wheels produce a magnetic field which may cause failure or permanent damage to items such as watches, memory devices, CRT monitors, medical devices or other electronics. People with pacemakers or ICD's must stay at least 25 cm (10 in) away.

1. Locate and position the threaded side of the magnetic wheel to the outside of the scanner.
2. Screw the magnetic wheel along the entire length of the axle.
3. Grip the magnetic wheel by hand, and using the supplied 3 mm hex driver (Fig. 12), tighten it to the axle (Fig. 24).

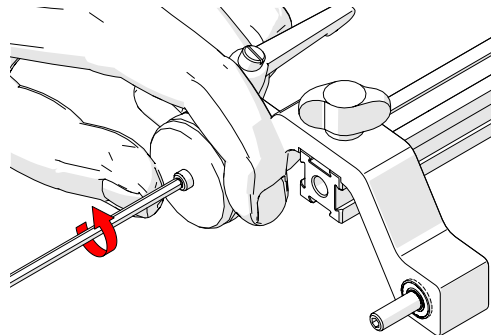

Fig. 24 - Wheel installation

5.3.2. Wheel Removal

1. Tightly grip the magnetic wheel to be removed. Using the 3 mm hex driver, loosen the magnetic wheel from the axle (Fig. 25).

TIP: When the brake is engaged, and the scanner is moved, the wheels may loosen from the axle. Grip the magnetic wheel tightly and retighten the axle with the 3 mm hex driver.

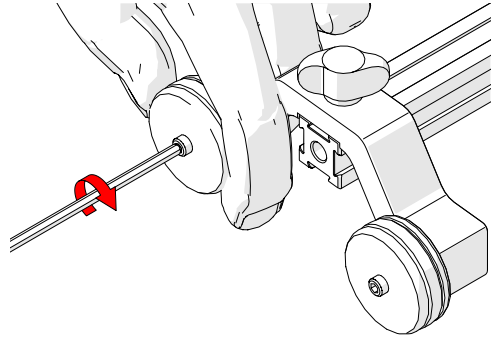

Fig. 25 - Wheel removal

5.3.3. Ratchet Lever

The ratchet levers lock the brakes of the **STIX** system. Occasionally, movement of the lever's locking position is required. The lever placement can be adjusted by following these steps:

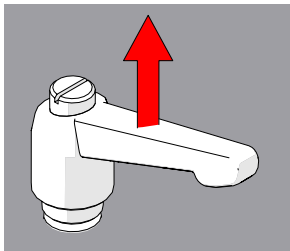

Fig. 26 - Pull ratchet handle

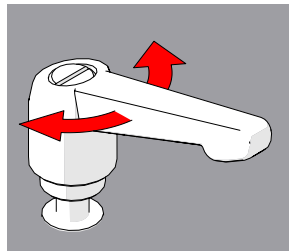

Fig. 27 - Rotate handle

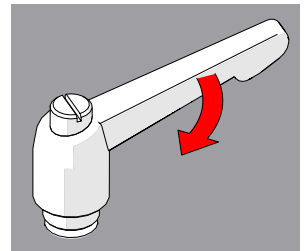

Fig. 28 - Tighten handle

1. Pull the ratchet lever away from the base to which it is connected (Fig. 26).
2. Continue to pull while rotating the lever in the appropriate direction (Fig. 27).
3. Release the lever and utilize the new tightening position (Fig. 28).

5.4. Frame Bar

Frame bars (Fig. 29) are used to mount probe holders, probe positioning systems and other accessories.

Frame bars are available in various lengths (see *Frame Bar* on page 13).

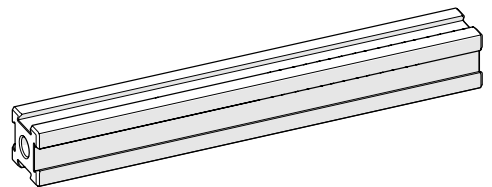

Fig. 29 - Frame bar

5.5. Spring-Loaded Encoder

The spring-loaded encoder wheel provides vertical travel while maintaining contact pressure to the scan surface. To install the encoder, follow these steps:

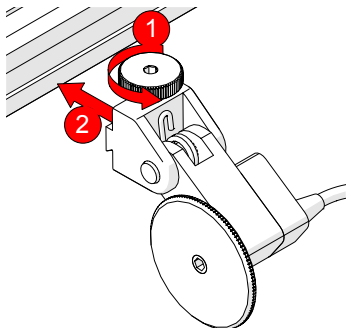

Fig. 30 - Attach to frame bar

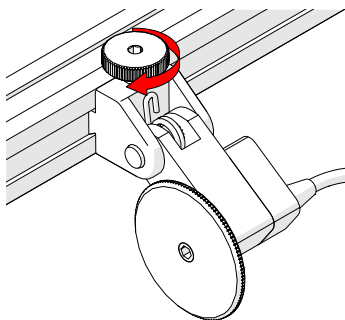

Fig. 31 - Tighten knob

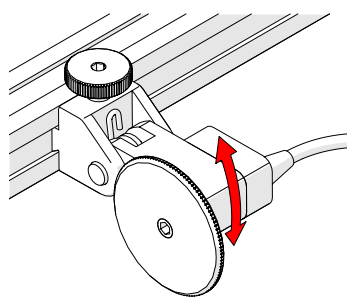

Fig. 32 - Place on scan surface

1. Loosen the encoder's dovetail jaw and mount it to the frame bar (*Fig. 30*).
2. Tighten the encoder knob (*Fig. 31*).
3. Spring tension maintains encoder contact with the scan surface (*Fig. 32*).

5.6. Spring-Loaded Probe Holder

A	Frame Bar
B	Probe Holder Adjustment Knob
C	Yoke
D	Probe Holder Arm Adjustment Knob
E	Probe Holder Arm
F	Pivot Button
G	Arm Clamp Screw

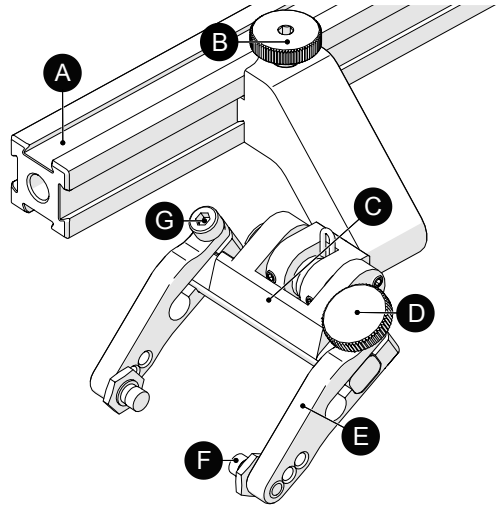

Fig. 33 - Spring-loaded probe holder

5.6.1. Probe Holder Setup

To mount a TOFD wedge in the spring-loaded probe holder, follow these steps:

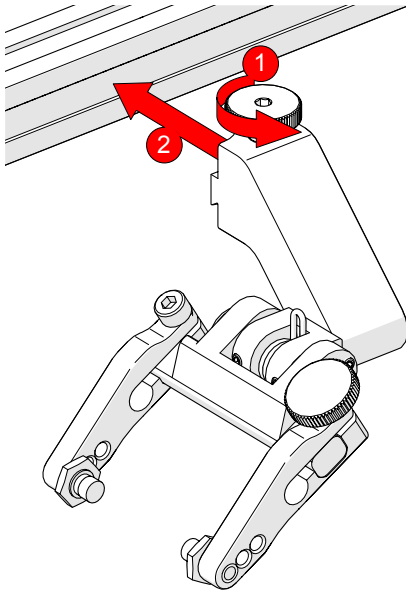

Fig. 34 - Attach to frame bar

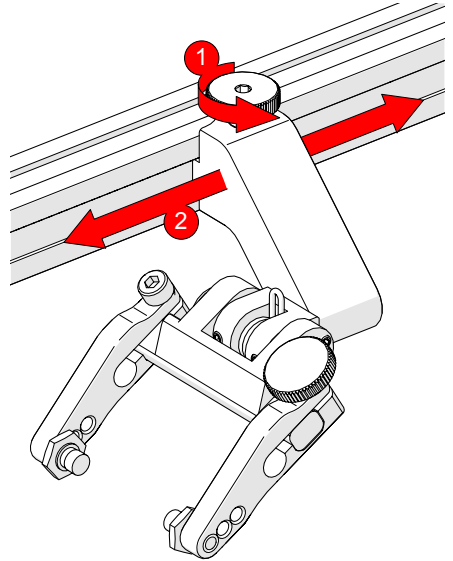

Fig. 35 - Position on frame bar

1. Rotate the probe holder adjustment knob and attach the probe holder to a frame bar (Fig. 34).
2. Use the probe holder adjustment knob to position the probe holder along the frame bar (Fig. 35).

TIP: Wedge pivoting may be impeded when pivot buttons are placed closer to the yoke (see *Pivot Buttons* on page 17).

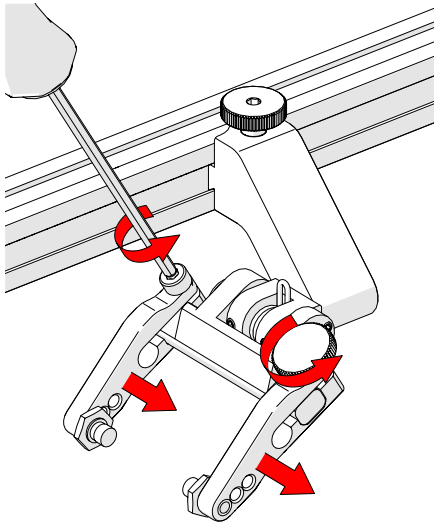

Fig. 36 - Adjust inner probe holder arm

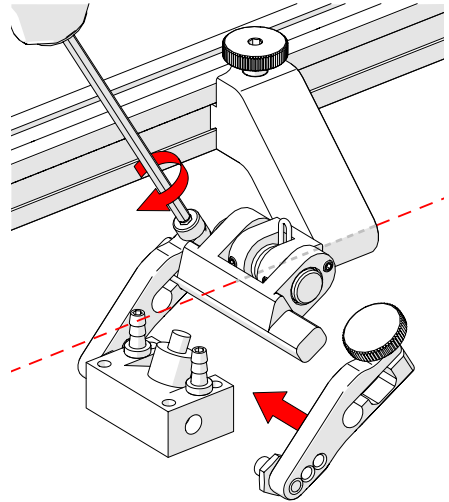

Fig. 37 - Place wedge and outer arm

3. Loosen the probe holder arm adjustment knob (Fig. 36) and remove the outer probe holder arm from the yoke.
4. Adjust the inner probe holder arm to best centre the probe on the yoke's pivot axis (Fig. 36).

TIP: The probe holder yoke can accommodate different probe and wedge sizes of varying widths. To reduce wedge tipping when scanning, centre the wedge with the yoke's pivot axis. Position the inner probe holder arm accordingly with the centre of the yoke (Fig. 37).

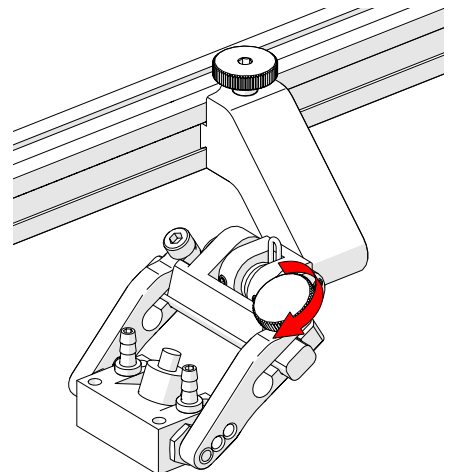

Fig. 38 - Tighten probe holder knob

5. Position the wedge on the inner probe holder arm (Fig. 37).
6. Slide the outer probe holder arm along the yoke, pinching the wedge in place (Fig. 37).
7. Tighten the probe holder arm adjustment knob (Fig. 38).

5.6.2. Pivot Buttons

Available in a variety of shapes and sizes fitting various wedge dimensions.

Use the supplied 3/8 in wrench (Fig. 13) to remove and install pivot buttons (Fig. 39).

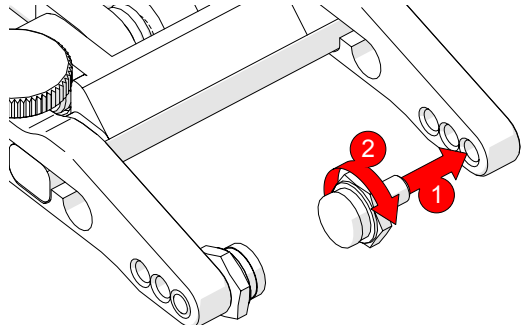

Fig. 39 - Pivot buttons

5.7. Magnetic Wheel Kit



WARNING! MAGNETIC MATERIAL. The magnetic wheels produce a magnetic field which may cause failure or permanent damage to items such as watches, memory devices, CRT monitors, medical devices or other electronics. People with pacemakers or ICD's must stay at least 25 cm (10 in) away.

Two sets of magnetic wheels can be used with the **STIX**, thus doubling the magnetic force.

NOTE: Magnetic wheels may lose their magnetic properties if heated above 175° F (80° C).

To install additional magnetic wheels, follow these steps:

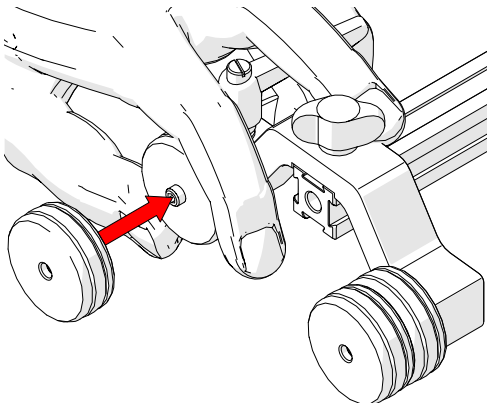

Fig. 40 - Screw on additional magnetic wheel

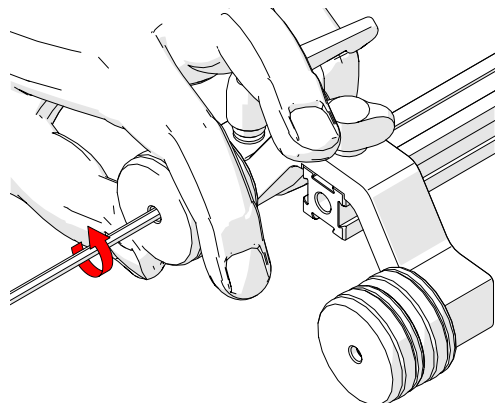

Fig. 41 - Tighten with 3 mm hex driver

1. Ensure the four existing wheels are tight (see *Wheel Installation on page 12*)
2. On the magnetic wheel to be attached, locate the threaded side and orient this threaded side towards the scanner.

3. By hand, grip the wheel already attached to the wheel block. Overcome the magnetic resistance to screw the additional wheel to the axle of the wheel block (Fig. 40).
4. Hold steady the magnetic wheel closest to the scanner body, insert the 3 mm hex driver into the axle and tighten the additional wheel (Fig. 41).

TIP: To remove additional wheels, reverse these steps.

5.8. Preamp Bracket

Compatible with most standard preamps, use screws or the optional velcro straps to attach a preamp to the preamp bracket.

Intended Use:

- ▶ The preamp bracket is intended to mount objects (e.g. preamps, splitters, etc.) that:
- ▶ have a maximum weight of 1.36 kg (3 lb)
- ▶ are attached to the with a lanyard or probe cables strong enough to prevent the object from falling
- ▶ have smooth edges so as not to cut the preamp velcro strap

5.8.1. Mounting Preamp Bracket

The preamp bracket mounts to any dovetail groove on a scanner or frame bar.

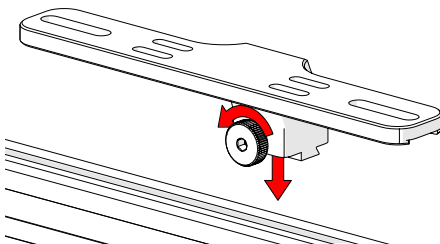

Fig. 42 - Loosen knob and mount to dovetail groove

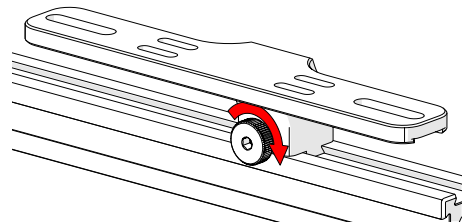

Fig. 43 - Tighten knob

1. Loosen the knob and align with the dovetail groove (Fig. 42).
2. Tighten the knob to lock the preamp bracket in place (Fig. 43).

5.8.2. Attaching Preamp with Screws

Use the adjustable screw mounting channel on the bottom of the bracket to attach a preamp (*screws not included*).

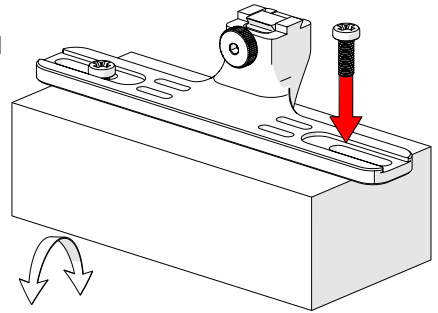

Fig. 44 - Attach preamp with screws

5.8.3. Attaching Preamp with Velcro Strap

To attach the preamp to the bracket using velcro straps (*sold separately*, follow these steps:

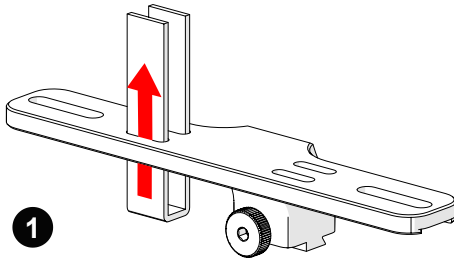

Fig. 45 - Insert velcro straps

1. Slide the velcro strap through the bracket's holes (Fig. 45).
2. Centre and place the preamp on the bracket wrapping the velcro around the preamp (Fig. 46).
3. Secure the preamp to the bracket, attaching each side of the velcro (Fig. 47).

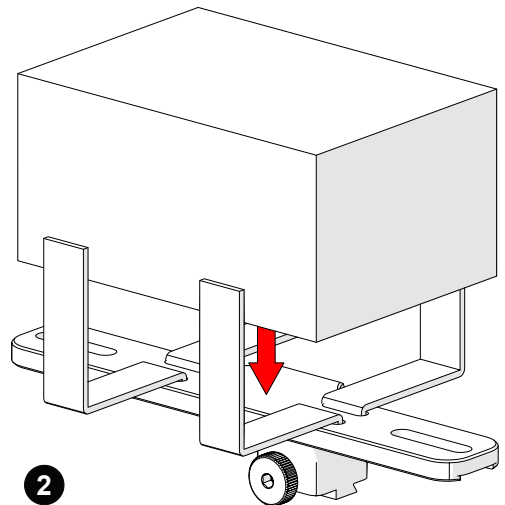

Fig. 46 - Place preamp and wrap velcro

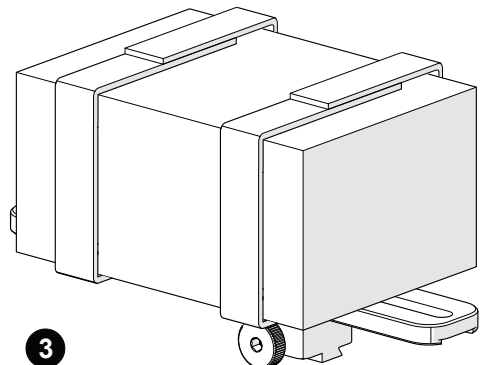

Fig. 47 - Mount bracket on a frame bar

OPERATION

6.1. STIX setup on a scan surface

1. Mount TOFD wedges to the probe holders (see *Spring-Loaded Probe Holder* on page 15).

TIP: Mounting the wedges to the spring-loaded probe holders can be easier when the probe holders are separate from the **STIX** frame bar.

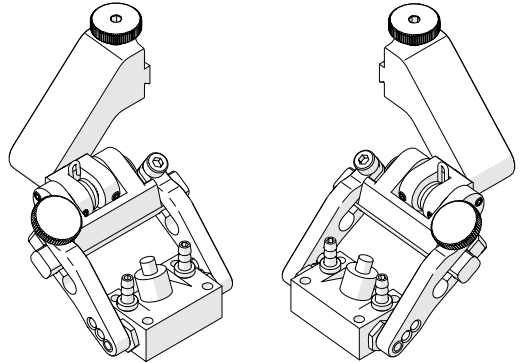

Fig. 48 - Mount wedges to probe holders

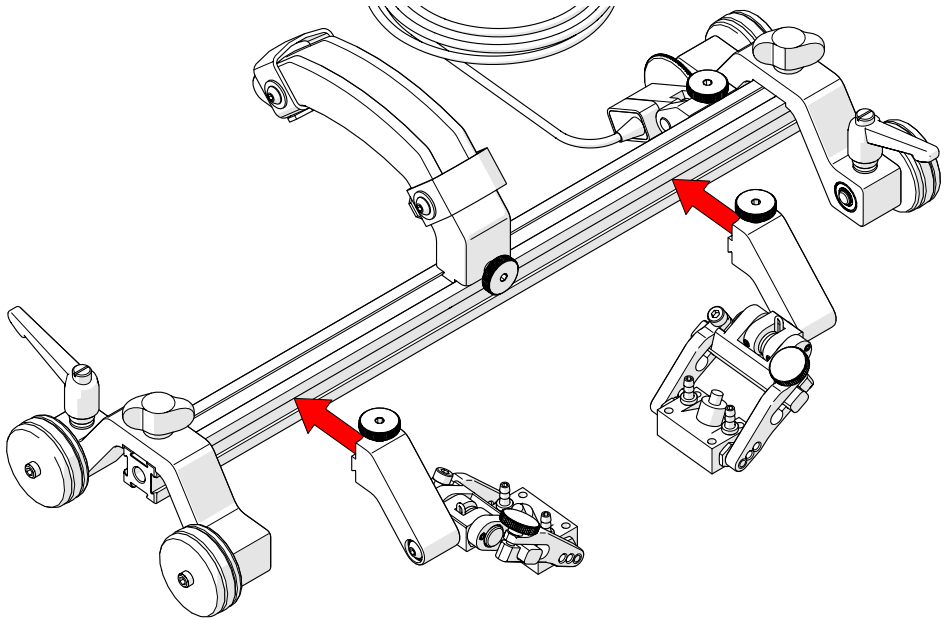

Fig. 49 - Attach spring-loaded probe holders to appropriate configuration

2. Assemble the appropriate configuration (Fig. 49). Attach the spring-loaded probe holders to the frame bar where appropriate.
3. Ensure the brakes are locked on the wheel blocks (see *Ratchet Lever* on page 13).

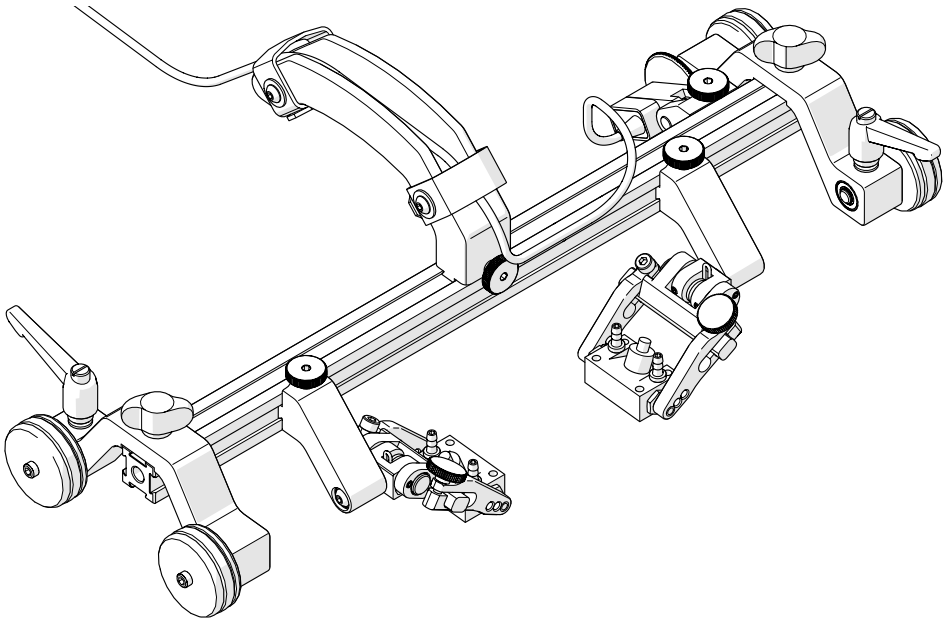

Fig. 50 - Use handle for cable management

4. Route cables and hoses through the handle (Fig. 50).

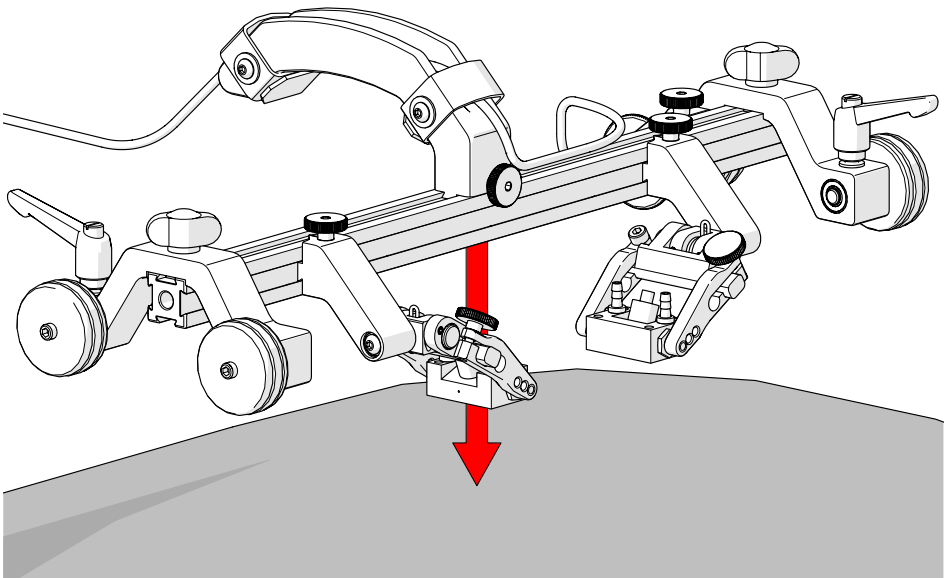

Fig. 51 - Place on scan surface

5. Place the configured **STIX** on the scan surface (Fig. 51).

TIP: Use caution when placing equipment on the scan surface. The magnetized wheels can cause the assembly to suddenly lurch towards the metal suddenly.

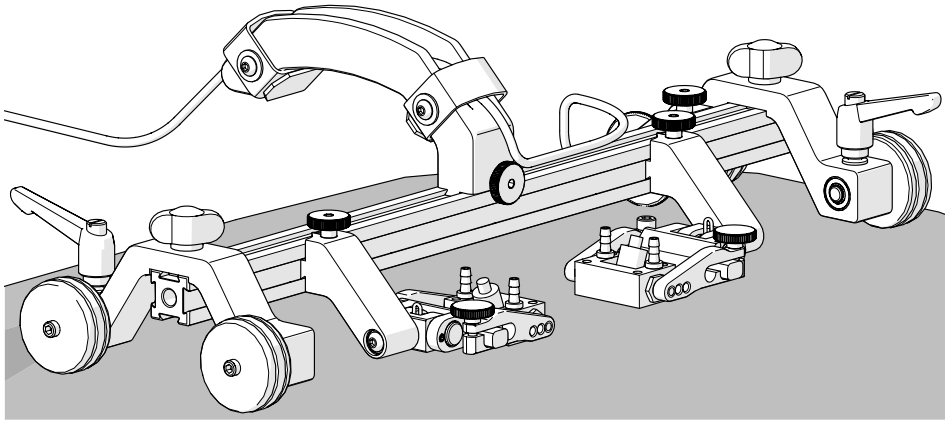

Fig. 52 - Prepared for scanning

6. The spring-loaded probe holders are designed to maintain wedge contact with the scan surface (Fig. 52), and the encoder is designed to maintain contact pressure on the scan surface for an accurate reading.
7. Release both brakes to begin the scanning procedure.

MAINTENANCE

General cleaning of components is important to keep your system working well. All components that have no wiring or cables are completely waterproof. Components can be washed with warm water, dish soap and a medium bristle brush.

Before using the scanner, ensure all connectors are free of water and moisture.

NOTE: *All components with wiring, cables or electrical connections are splashproof. However, these components are **NOT** submersible.*

NOTE: *Never use strong solvents or abrasive materials to clean your scanner components.*

TROUBLESHOOTING

Problem	Possible Cause	Solution
The encoder not functioning.	The instrument is not correctly set up.	Refer to instrument's documentation regarding proper setup.
	Issue with encoder.	Contact Jireh Industries for repair (<i>see Jireh Industries Ltd. on page 1</i>).
Insufficient probe contact.	The scanner not set correctly.	Reconfigure the scanner per instructions (<i>see Spring-Loaded Probe Holder on page 15</i>).
Magnetic wheels become loose.	Brakes are engaged.	Ensure the brakes are unlocked when using the scanner (<i>see Wheel Block on page 12</i>).

8.1. Technical Support

For technical support contact Jireh Industries (*see "Jireh Industries Ltd." on page 1*).

SERVICE AND REPAIR



WARNING! DO NOT DISASSEMBLE. No user-serviceable parts. Disassembling any of the components in this product, beyond the instructions in this user manual, could void the regulatory certifications and/or effect the safety of the product.

SPARE PARTS

To order accessories or replacement parts for your **STIX** system.
(contact Jireh Industries Ltd. on page 1)

NOTE: These drawings are for the order of parts. This is not a list of kit contents.

10.1. Scanner

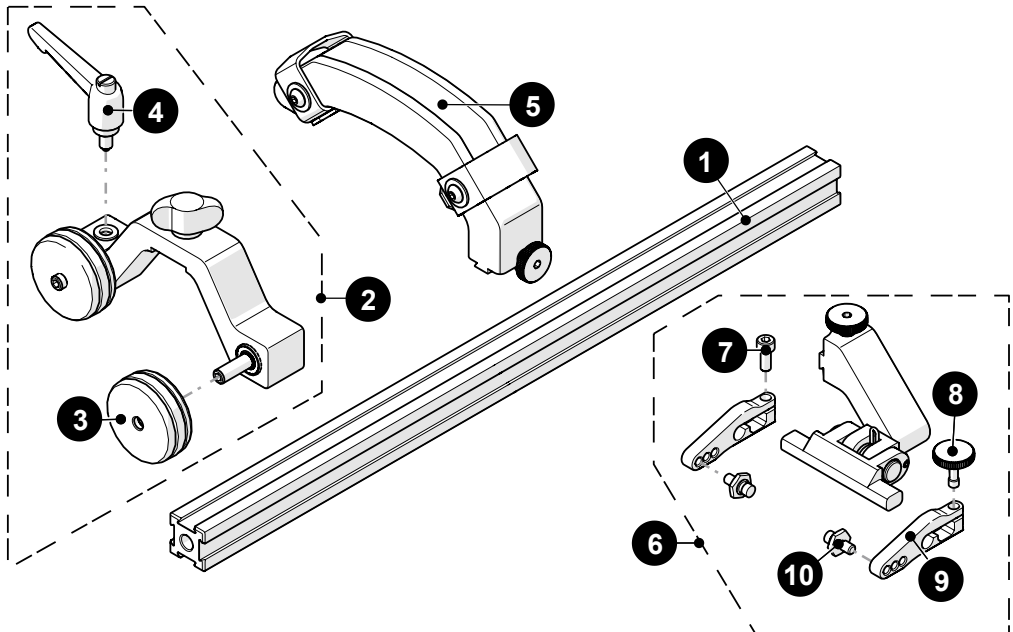

BOM ID	Part #	Description
1	BG0038-35	Frame Bar, 35 cm
2	BGS056	Wheel Block
3	BTS031	Magnetic Wheel
4	BTS018	Brake Handle
5	BGS054	Handle
6	PHS033-X-Y	Spring-Loaded Probe Holder (see Pivot Button Style, Y=L,R)
7	MD050-010	SHCS, M4 x 0.7 x 10 mm, SST
8	PH0082	Knurled Knob, M4 x 0.7 x 10 mm, 3 mm stand off, SST
9		see Spring-Loaded Arm Style
10	PH0011-X	(see Pivot Button Style)

Fig. 53 - Scanner parts

10.2. Kit Components

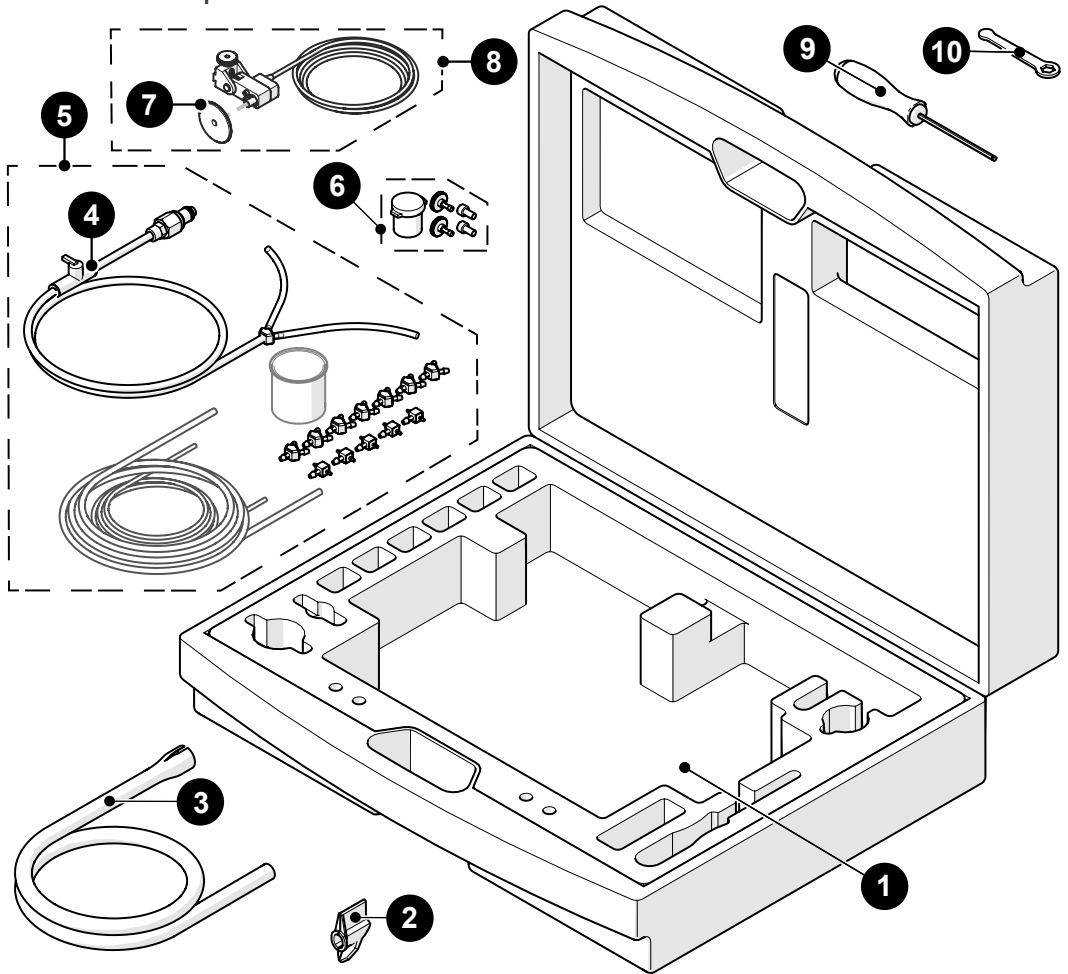

BOM ID	Part #	Description
1	BGA010	STIX Case, TOFD
2	EA302	Loom Installation Tool
3	SP040	Cable Sleeving
4	LA034	Irrigation Shutoff Valve
5	CMG007	Irrigation Kit, 2-4 Probe
6	PHG014	2 Probe Spare Parts Kit
7	BG0069	Encoder wheel, for spring-loaded encoder
8	BGS053-X	Spring-Loaded Encoder (<i>see Encoder Con. Type</i>)
9	EA414	3 mm Hex Driver
10	EA470	3/8 in Wrench

Fig. 54 - STIX kit components

10.2.1. Encoder Connector Type

Connector Type	Company/Instrument	Connector Type	Company/Instrument
B	Olympus OmniScan MX Zetec Topaz	G	Sonotron Isonic 25xx
C	Olympus Focus LT Zetec Z-Scan Eddyfi Ectane 2	U	Sonatest Veo / Prisma
E	Olympus OmniScan SX/MX2/X3 M2M MANTIS/GEKKO LEMO	V	Pragma PAUT
F	TD (<i>Technology Design</i>)	AD	Sonatest Veo / Prisma - Single Axis

NOTE: Additional encoder connector styles are available. (contact Jireh Industries Ltd. on page 1 for details)

10.3. Accessories

10.3.1. Magnetic Wheel Kit

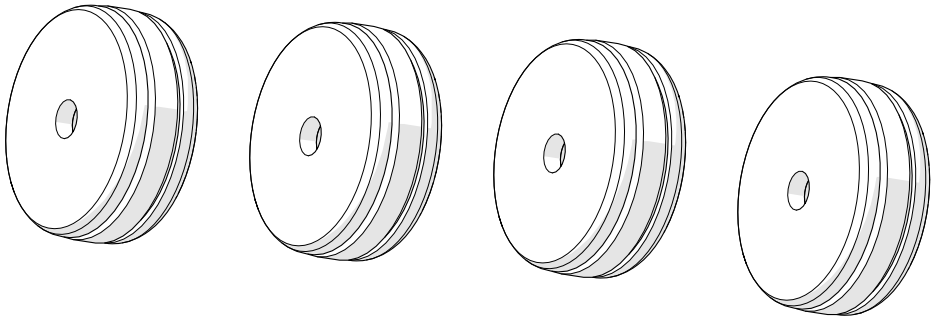

Part #	Description
BTG014	Magnetic Wheel Kit

Fig. 55 - Magnetic wheel kit

10.3.2. Preamp Bracket

BOM ID	Part #	Description
1	CES029	Preamp Bracket
2	CES029-V	Preamp Bracket with Velcro

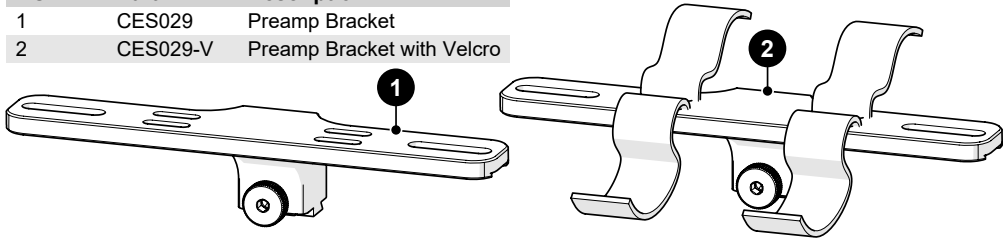
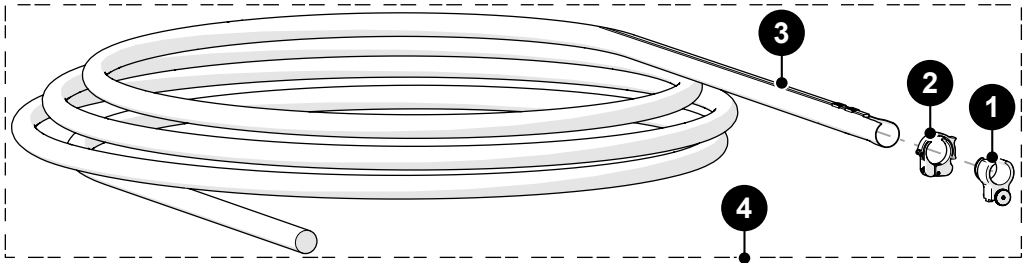

Fig. 56 - Preamp bracket

10.3.3. Cable Management



BOM ID	Part #	Description
1	CES067	Cable Management Mount, Dovetail Mount
2	CES066	Cable Management Clamp, Dovetail Mount
3		See <i>Cable Management Sleeving</i>
4	CES044- <u> </u>	Cable Management: Dovetail (<i>see cable management sleeving</i>)

Fig. 57 - Cable management

10.3.3.1 Cable Management Sleeving

Part #	Length
CX0141	4.5 m (14.7 ft)
CX0145	9.5 m (31.2 ft)

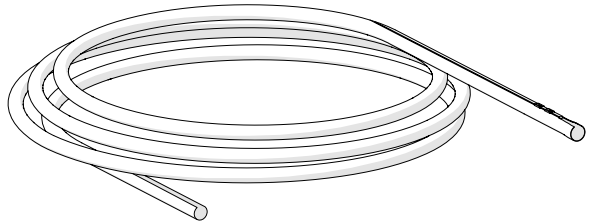
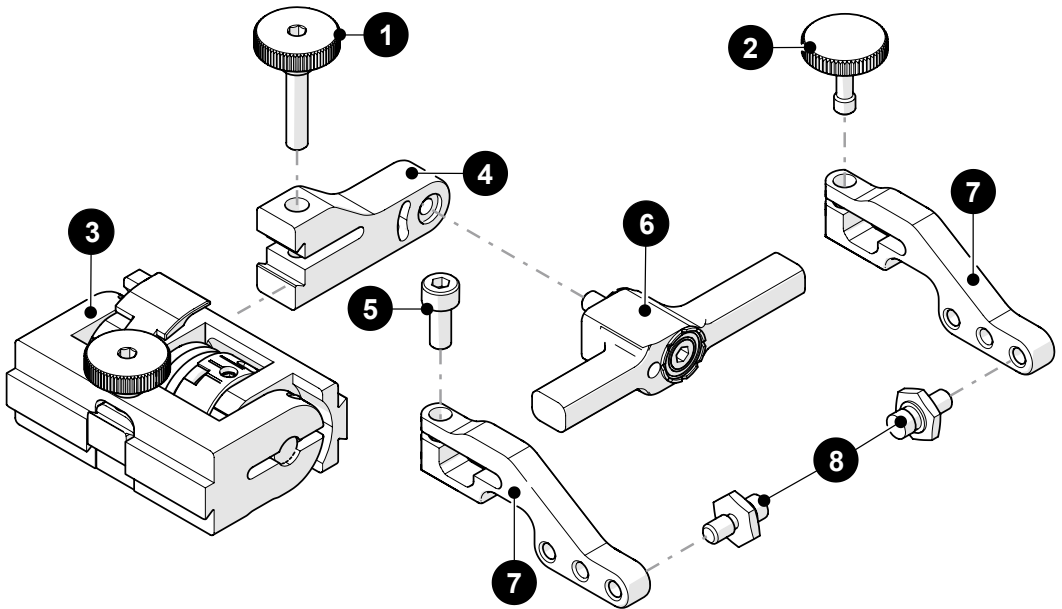

Fig. 58 - Cable management sleeving

10.4. Probe Holders

10.4.1. Slip Joint Probe Holder Parts



BOM ID	Part #	Description
1	PH0104	Knurled Knob, M4 x 0.7 x 18 mm, 4 mm stand off, SST
2	PH0082	Knurled Knob, M4 x 0.7 x 10 mm, 3 mm stand off, SST
3	PHS022	Slip Joint Probe Holder Subassembly
4		<i>see Swing Arm Style</i>
5	MD050-010	SHCS, M4 x 0.7 x 10 mm, SST
6		<i>see Yoke Style</i>
7		<i>see Arm Style</i>
8	PH0011-__	Pivot Button Style (<i>see Pivot Button Style</i>)

Fig. 59 - Slip joint probe holder parts

10.4.2. Vertical Probe Holder Parts

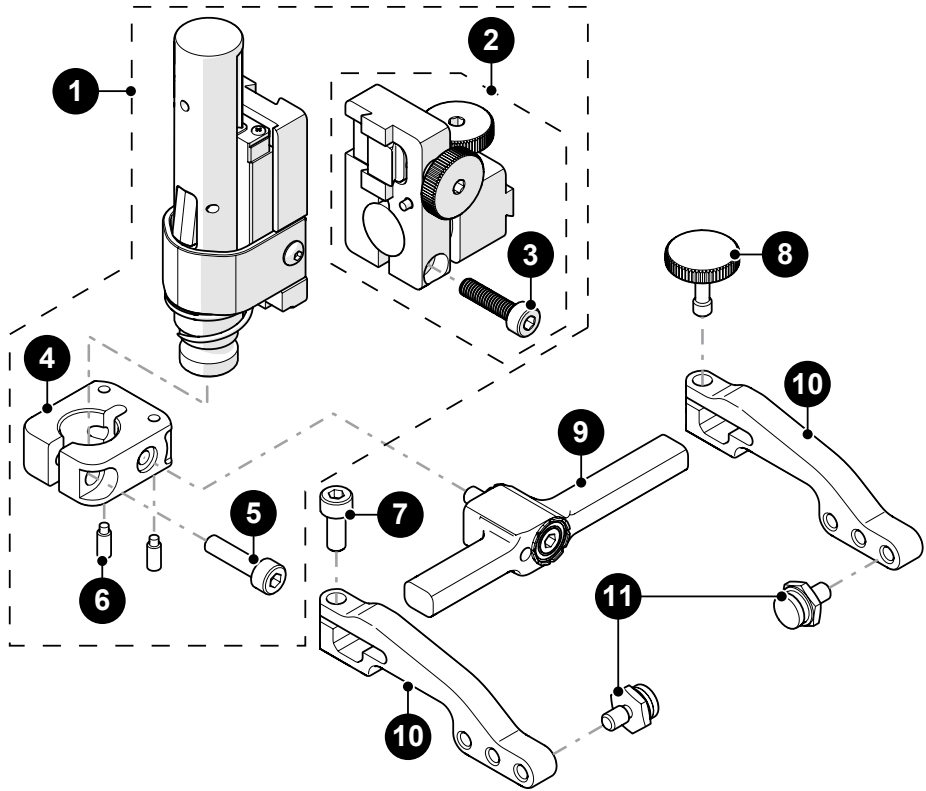

BOM ID	Part #	Description
1	PHS028	Vertical Probe Holder Subassembly
2	PHS061	Vertical Probe Holder Sub-Assembly: pivoting mount
3	MA307	Screw, M4x16 mm High Strength SST SHCS
4	PH0087	Vertical Probe Holder Base
5	MD050-016	SHCS, M4 x 0.7 x 16 mm, SST
6	MA096	Screw, M3x8 mm Dog Point Set, SST
7	MD050-010	SHCS, M4 x 0.7 x 10 mm, SST
8	PH0082	Knurled Knob, M4 x 0.7 x 10 mm, 3 mm stand off, SST
9	<i>see Yoke Style</i>	
10	<i>see Arm Style</i>	
11	PH0011- <u> </u>	Pivot Button Style (<i>see Pivot Button Style</i>)

Fig. 60 - Vertical probe holder parts

10.5. Probe Holder Components

10.5.1. Spring-Loaded Arm Style



Arm Style	Part #	Image	Arm Style	Part Number	Image
A Standard	PH0090		B Short	PH0089	

Fig. 61 - Spring-loaded probe holder arm selection

10.5.2. Slip Joint and Vertical Probe Holder Arm Style









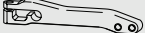

Arm Style	Part #	Image	Arm Style	Part #	Image
A Standard, Flat	PH0090		B Short, Flat	PH0089	
C Long, Flat	PH0099		D Standard, Drop	PH0093	
E Short, Drop	PH0092		F Long, Drop	PH0094	
G Standard, Extra-Drop	PH0096		H Short, Extra-Drop	PH0095	
I Extra-Short, Flat	PH0159		J Extra-Short, Drop	PH0161	

Fig. 62 - Slip joint and vertical probe holder arm selection

10.5.3. Slip Joint and Vertical Probe Holder Yoke Style

Yoke Style	Part #	Length	Image	Yoke Style	Part #	Length	Image
S Standard	PHS052	6.3 cm (2.47 in)		W Wide	PHS063	7.9 cm (3.06 in)	

Fig. 63 - Slip joint and vertical probe holder arm selection

10.5.4. Swing Arm Style

Swing Arm Style	Part #	Length	Image	Swing Arm Style	Part #	Length	Image
Short	PH0069	4.1 cm (1.61 in)		Long	PH0100	4.6 cm (1.81 in)	

Fig. 64 - Swing arm selection

NOTE: The short swing arm is only compatible with the standard yoke style.

10.5.5. Pivot Button Style









	Pivot Hole Size	Wedge Type			Pivot Hole Size	Wedge Type	
01	8.0 mm (0.315 in)	Olympus PA		02	5.0 mm (0.197 in)	Olympus TOFD	
03	2.7 mm (0.106 in)	Sonatest DAAH PA		04	9.5 mm (0.375 in)	-	
06	3.0 mm (0.118 in)	-		07	2.3 mm (0.09 in)	-	
08	Conical Head	-		09	5 mm (0.197 in) Internal	Zetec PA/TOFD	

Fig. 65 - Probe holder button selection

NOTE: Additional probe holder pivot button types are available. (contact Jireh Industries Ltd. on page 1)

10.6. Variable Components

10.6.1. Frame Bars











Part #	Length		Part #	Length	
BG0038-05	5 cm (1.97 in)		BG0038-10	10 cm (3.94 in)	
BG0038-15	15 cm (5.91 in)		BG0038-20	20 cm (7.87 in)	
BG0038-25	25 cm (9.84 in)		BG0038-30	30 cm (11.81 in)	
BG0038-35	35 cm (13.78 in)		BG0038-40	40 cm (15.75 in)	
BG0038-45	45 cm (17.72 in)		BG0038-50	50 cm (19.69 in)	
BG0038-55	55 cm (21.65 in)				

Fig. 66 - Frame bar selection

DISPOSAL

WEEE Directive

In accordance with European Directive on Waste Electrical and Electronic Equipment (WEEE), this symbol indicates that the product must not be disposed of as unsorted municipal waste, but should be collected separately. Refer to Jireh Industries for return and/or collection systems available in your country.



LIMITED WARRANTY

WARRANTY COVERAGE

Jireh Industries warranty obligations are limited to the terms set forth below: Jireh Industries Ltd. (“Jireh”) warrants this hardware product against defects in materials and workmanship for a period of THREE (3) YEARS from the original date of purchase. If a defect exists, at its option Jireh will (1) repair the product at no charge, using new or refurbished replacement parts, (2) exchange the product with a product that is new or which has been manufactured from new or serviceable used parts and is at least functionally equivalent to the original product, or (3) refund the purchase price of the product. A replacement product/part assumes the remaining warranty of the original product or ninety (90) days from the date of replacement or repair, whichever provides longer coverage for you. When a product or part is exchanged, any replacement item becomes your property and the replaced item becomes Jireh’s property. When a refund is given, your product becomes Jireh’s property.

OBTAINING WARRANTY SERVICE

To utilize Jireh’s warranty service you must ship the product, at your expense, to and from Jireh Industries. Before you deliver your product for warranty service you must phone Jireh and obtain an RMA number. This number will be used to process and track your product. Jireh is not responsible for any damage incurred during transit.

EXCLUSIONS AND LIMITATIONS

This Limited Warranty applies only to hardware products manufactured by or for Jireh Industries. This warranty does not apply: (a) to damage caused by accident, abuse, misuse, misapplication, or non-Jireh products; (b) to damage caused by service (including upgrades and expansions) performed by anyone who is not a Jireh Authorized Service Provider; (c) to a product or a part that has been modified without the written permission of Jireh.

Jireh Industries Ltd.
53158 Range Rd 224
Ardrossan AB T8E 2K4
Canada

Phone: 780-922-4534
jireh.com

All brands are trademarks or registered trademarks of their respective owners and third-party entities.

Changes or modifications to this unit or accessories not expressly approved by the party responsible for compliance could void the user's authority to operate the equipment.

All specifications are subject to change without notice.

© 2018 - 2025 JIREH Industries Ltd.



Jireh Industries Ltd.
53158 Range Road 224
Ardrossan, Alberta
Canada
T8E 2K4

780-922-4534

jireh.com