



**ROTIX**

CE0206 Rev 00.6  
Manual Weld Frame Scanner

---

# SAFETY WARNINGS / PRECAUTIONS

## **KEEP THIS MANUAL – DO NOT LOSE**

THIS MANUAL IS PART OF THE **ROTIX** AND MUST BE RETAINED FOR THE LIFE OF THE PRODUCT. PASS ON TO SUBSEQUENT OWNERS.

Ensure any amendments are incorporated with this document.



**WARNING!** The **ROTIX** is designed for a specific use. Using the **ROTIX** outside of its intended use could cause damage to the product. Read and understand this manual before using.



**WARNING! MAGNETIC MATERIAL.** The wheels of this device produce a magnetic field which may cause failure or permanent damage to items such as watches, memory devices, CRT monitors, medical devices or other electronics.



People with pacemakers or ICD's must stay at least 25 cm (10 in) away at all times.



**WARNING! HOT SURFACE.** The **ROTIX** may reach temperatures that may cause burns if contacted with bare skin. Wear heat resistant safety gloves when handling.



**WARNING! DO NOT DISASSEMBLE.** No user-serviceable parts. Disassembling any of the components in this product, beyond the instructions in this user manual, could void the regulatory certifications and/or effect the safety of the product.



The **WEEE** symbol indicates that the product must not be disposed of as unsorted municipal waste, but should be collected separately.

(see *Disposal* on page 55 for additional details).



---

# TABLE OF CONTENTS

<b>1</b>	<b>Identification</b> .....	<b>1</b>
	1.1. Product Brand .....	1
	1.1.1. Manufacturer .....	1
<b>2</b>	<b>Product Specifications</b> .....	<b>2</b>
	2.1. Base ROTIX Specifications .....	2
	2.1.1. Intended Use .....	2
	2.1.2. Operating Limits .....	2
	2.1.3. Operating Environment .....	2
	2.1.4. Dimensions and Weight .....	3
	2.1.5. Environmental Sealing .....	4
	2.1.6. Performance Specifications .....	4
<b>3</b>	<b>Definitions</b> .....	<b>5</b>
	3.1. Definition of Symbols .....	5
	3.2. Definitions of Terms .....	5
<b>4</b>	<b>System Components</b> .....	<b>6</b>
	4.1. Base System Components .....	6
	4.1.1. Wheel Block with Handle .....	6
	4.1.2. Spring-Loaded Encoder .....	6
	4.1.3. Slip Joint Probe Holder .....	6
	4.1.4. Standard Overtop Link .....	7
	4.1.5. Frame Bar .....	7
	4.1.6. Irrigation Kit .....	7
	4.1.7. QuickLink Components .....	8
	4.1.7.1. QuickLink .....	8
	4.1.7.2. Dovetail QuickLink .....	8
	4.1.7.3. QuickLink Buckle .....	8
	4.1.8. Tools .....	9
	4.1.9. Case .....	9
	4.2. Compatible Components .....	10
	4.2.1. Cable Management, Dovetail Mount .....	10
	4.2.2. Encoder Adapter .....	10
	4.2.3. Preamp Bracket .....	10
	4.2.4. Frame Bar .....	11

4.3.	High Temperature Base System Components .....	12
4.3.1.	HT Wheel Block with Handle .....	12
4.3.2.	High Temperature Spring-Loaded Encoder .....	12
4.3.3.	Slip Joint Probe Holder .....	12
4.3.4.	High Temperature Standard Overtop Link .....	13
4.3.5.	Frame Bar .....	13
4.3.6.	Irrigation Kit .....	13
4.3.7.	High Temperature Cable Management, Dovetail Mount .....	14
4.3.8.	Cable Clip .....	14
4.3.9.	HT QuickLink Components .....	14
4.3.9.1	High Temperature Dovetail QuickLink .....	14
4.3.9.2	High Temperature QuickLink Buckle .....	15
4.3.10.	Tools .....	15
4.3.11.	Case .....	15
4.4.	Tools .....	16
4.4.1.	Included Tools .....	16
4.4.2.	Optional tools .....	16

## **5** Preparation for use .....17

5.1.	Configurations .....	17
5.1.1.	Two Probe Scanning .....	17
5.1.2.	Four Probe Scanning .....	17
5.1.3.	Four Probe Cantilever Scanning .....	18
5.1.4.	High Temperature Scanning .....	18
5.2.	Wheel Block with Handle .....	19
5.2.1.	Attaching a Frame Bar .....	19
5.2.2.	Wheel Removal/Installation .....	19
5.2.3.	Brake .....	20
5.2.4.	Ratchet Lever .....	20
5.2.5.	Dovetail Grooves .....	21
5.3.	Double Chain Mount .....	21
5.4.	Connecting QuickLinks & Dovetail Links .....	22
5.4.1.	Connecting QuickLinks .....	22
5.4.2.	Disconnecting QuickLinks .....	22
5.4.3.	Disconnecting the Dovetail QuickLink .....	23
5.4.4.	Attaching Connector Link .....	23
5.5.	Cable Clips .....	25
5.6.	Spring-Loaded Encoder .....	25
5.7.	Frame Bar .....	26
5.8.	Slip Joint Probe Holder .....	27
5.8.1.	Probe Holder Setup .....	27

5.8.2.	Probe Holder Adjustment .....	29
5.8.3.	Probe Holder Force Adjustment .....	29
5.8.4.	Slip Joint Probe Holder Left/Right Conversion .....	31
5.8.5.	Pivot Buttons .....	32
5.9.	Cable Management System .....	33
5.9.1.	Cable Management Dovetail Mount .....	33
5.9.2.	Cable Management Setup .....	34
5.9.3.	Clamp Setup .....	35
5.10.	High Temperature Weld Frame Scanner .....	36
5.11.	Magnetic Wheel Kit .....	37
5.12.	Preamp Bracket .....	38
5.12.1.	Mounting Preamp Bracket .....	38
5.12.2.	Attaching Preamp with Screws .....	38
5.12.3.	Attaching Preamp with Velcro Straps .....	39

<b>6</b>	<b>Operation .....</b>	<b>40</b>
6.1.	Setup of ROTIX on a Scanning Surface .....	40

<b>7</b>	<b>Maintenance .....</b>	<b>44</b>
----------	--------------------------	-----------

<b>8</b>	<b>Troubleshooting .....</b>	<b>45</b>
8.1.	Technical Support .....	45

<b>9</b>	<b>Service and Repair .....</b>	<b>46</b>
----------	---------------------------------	-----------

<b>10</b>	<b>Spare Parts .....</b>	<b>47</b>
10.1.	Standard Kit Components .....	47
10.2.	High Temperature Kit Components .....	48
10.2.1.	Encoder Connector Type .....	49
10.3.	Accessories .....	50
10.3.1.	Cable Management, Dovetail Mount .....	50
10.3.1.1	Cable Management Sleeving .....	50
10.3.2.	High Temperature Cable Management, Dovetail Mount .....	50
10.3.3.	Preamp Bracket .....	51
10.3.4.	Magnetic Wheel Kit .....	51
10.4.	Probe Holders .....	52
10.4.1.	Slip Joint Probe Holder Parts .....	52
10.5.	Probe Holder Components .....	53

10.5.1. Arm Style .....	53
10.5.2. Yoke Style .....	53
10.5.3. Swing Arm Style .....	53
10.5.4. Pivot Button Style .....	53
10.6. Variable Components .....	54
10.6.1. Frame Bars .....	54
10.7. Case .....	54

<b>11</b> Disposal .....	<b>55</b>
<b>12</b> Limited Warranty .....	<b>56</b>
<b>13</b> Appendix .....	<b>58</b>
13.1. Weld Frame Setup Chart .....	58

# IDENTIFICATION

## 1.1. Product Brand

This user manual describes the proper safety precautions, setup and use of the **ROTIX** scanner.

### 1.1.1. Manufacturer

Distributor:

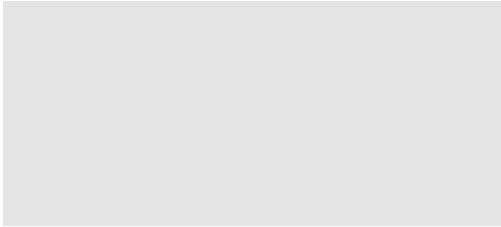

Manufacturer:

Jireh Industries Ltd.  
53158 Range Road 224  
Ardrossan, Alberta, Canada  
T8E 2K4  
780.922.4534  
jireh.com

# PRODUCT SPECIFICATIONS

## 2.1. Base ROTIX Specifications

### 2.1.1. Intended Use

The **ROTIX** chain scanner is a manually operated scanner which provides encoded probe positions of two or four probes. The double wheel chain components straddle the weld and fasten a scanning frame circumferentially around pipe or tubing.

### 2.1.2. Operating Limits

Category	Parameter	Specification
Inspection Surface	Minimum OD, external circumferential pipe/tube range	10.2 cm (4 in)
	Maximum OD, external circumferential pipe/tube range	96.5 cm (38 in)

### 2.1.3. Operating Environment

The **ROTIX** chain scanner is designed for use in an industrial environment that is between -20°C and 50°C (-4°F and 122°F).

The **ROTIX** - High Temperature Kit is required for surface temperatures between 50°C and 350°C (122°F and 662°F).

## 2.1.4. Dimensions and Weight

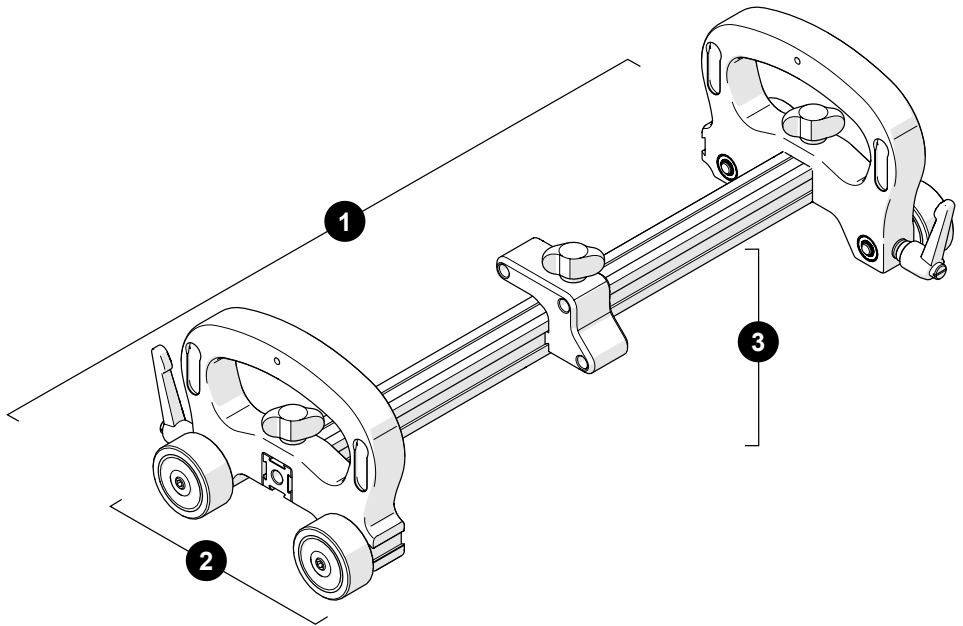

Fig. 1 - Frame dimensions

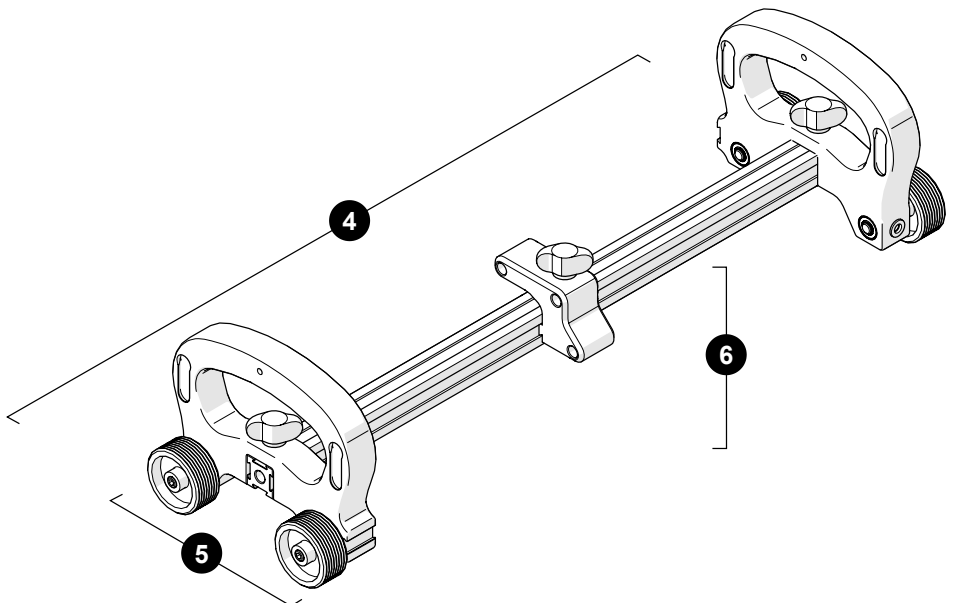

Fig. 2 - High temperature frame dimensions

1	Frame width (Fig. 1-1):	38.5 cm	(15.2 in)
2	Frame depth (Fig. 1-2):	17.5 cm	(6.9 in)
3	Frame height (Fig. 1-3):	10.5 cm	(4.1 in)
4	HT frame width (Fig. 2-4)	43.5 cm	(17.1 in)
5	HT frame depth (Fig. 2-5)	12.5 cm	(4.9 in)
6	HT frame height (Fig. 2-6)	10.5 cm	(4.1 in)
	Encoder cable length	5 m	(16.4 in)

### 2.1.5. Environmental Sealing

Watertight (*submersible*) (contact *Jireh Industries Ltd.* on page 1 for details).

### 2.1.6. Performance Specifications

Category	Specification
X-Axis encoder resolution	9.05 counts/mm (230.0 counts/in)
High Temperature X-Axis encoder resolution	4.28 counts/mm (108.7 counts/in)

# DEFINITIONS

## 3.1. Definition of Symbols



Instructions to 'look here' or to 'see this part'.

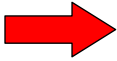

Denotes movement. Instructing user to carry out an action in a specified direction.

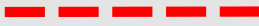

Indicates alignment axis.



Alerts user that the view has changed to a reverse angle.

## 3.2. Definitions of Terms

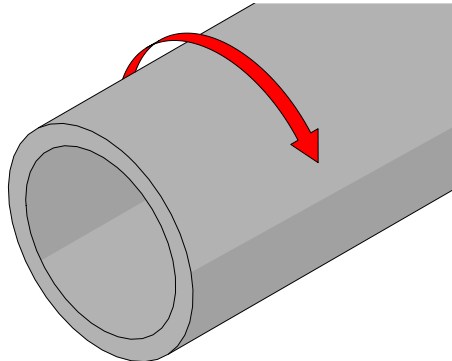

Fig. 3 - Circumferential scanning

**Circumferential**

Direction of scan travel is around the circumference of the pipe/tube (Fig. 3).

## SYSTEM COMPONENTS

### 4.1. Base System Components

#### 4.1.1. Wheel Block with Handle CES070

The wheel block provides stability and braking to the **ROTIX** system (Fig. 4).

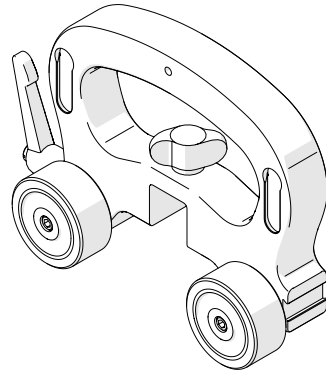

Fig. 4 - Wheel block with handle

#### 4.1.2. Spring-Loaded Encoder BGS053-

The Spring-Loaded Encoder mounts to any standard frame bar. The spring-loaded encoder wheel maintains contact pressure on the scan surface (Fig. 5).

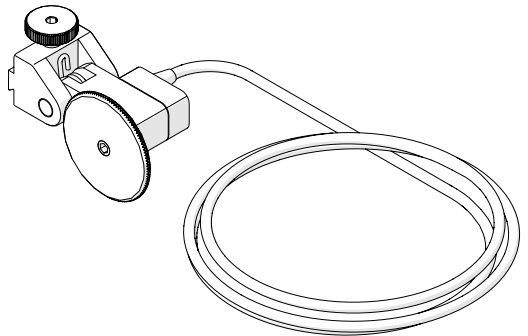

Fig. 5 - Spring-loaded encoder

#### 4.1.3. Slip Joint Probe Holder PHA012-

The slip joint probe holder is generally used during limited access inspection. The low profile design requires minimal radial clearance. The slip joint probe holder is designed to carry many different types of probes and wedges. It is available with various types of yokes, arms and pivot buttons (Fig. 6).

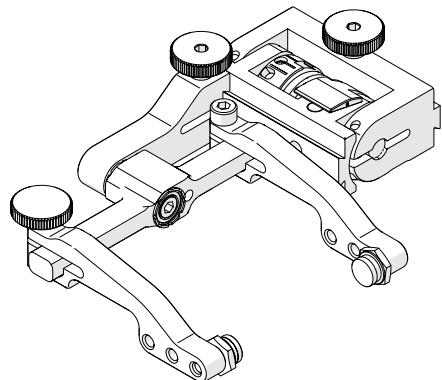

Fig. 6 - Slip joint probe holder

#### 4.1.4. Standard Overtop Link EJS013

The standard overtop link attaches to the double chain mount of the frame and reach overtop of the slip joint probe holders and connect to the QuickLinks (Fig. 7).

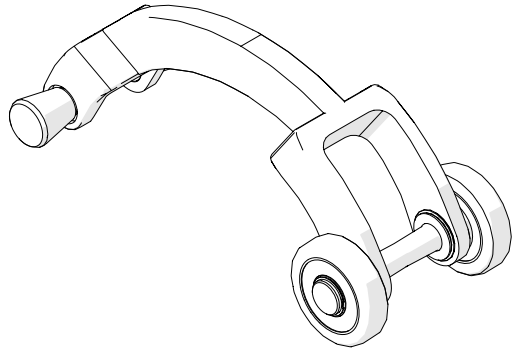

Fig. 7 - Standard overtop link

#### 4.1.5. Frame Bar BG0038-

Frame bars provide a mount probe holders, probe positioning systems and other accessories.

Frame bars are available in a variety of lengths (Fig. 8).

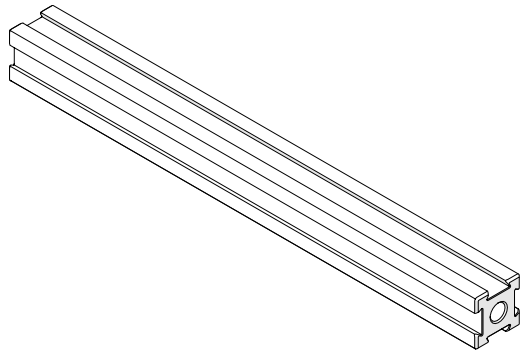

Fig. 8 - Frame bar

#### 4.1.6. Irrigation Kit CMG007

The irrigation kit provides a variety of hoses, fittings, connectors, and splitters commonly used during non-destructive inspection (Fig. 9).

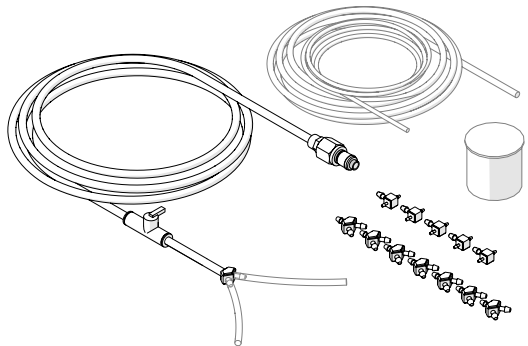

Fig. 9 - Irrigation kit

## 4.1.7. QuickLink Components

The QuickLink components fasten a ROTIX system circumferentially around a pipe or tube.

### 4.1.7.1 QuickLink EES004

QuickLinks connect to assemble the required length to mount the system on a pipe (Fig. 10).

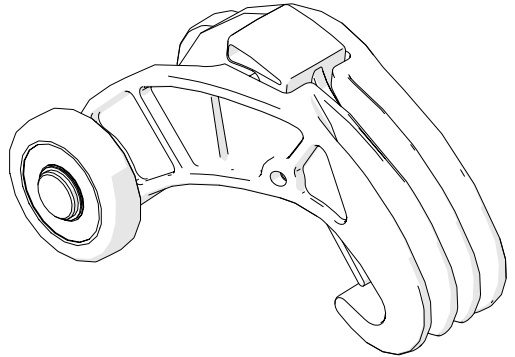

Fig. 10 - QuickLink

### 4.1.7.2 Dovetail QuickLink EES019

The Dovetail QuickLink connects to QuickLinks, providing a mounting point for accessories such as cable management (Fig. 11).

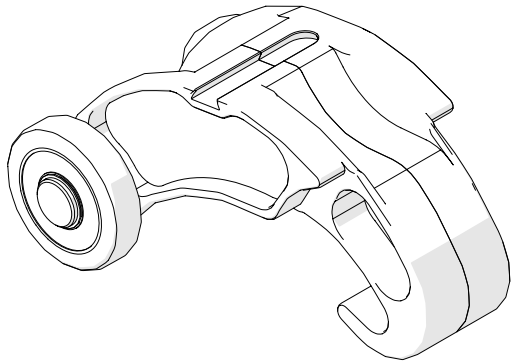

Fig. 11 - Dovetail QuickLink

### 4.1.7.3 QuickLink Buckle EES014

The QuickLink Buckle enables adjustment of the chain tension and provides the connection point of the QuickLinks assembly (Fig. 12).

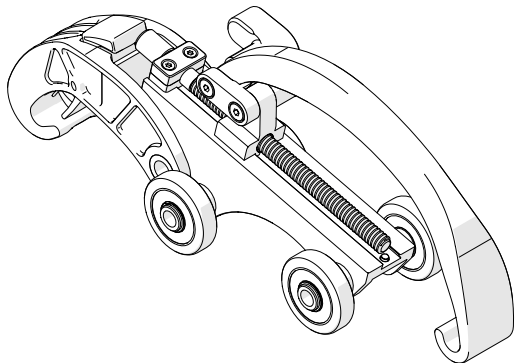

Fig. 12 - QuickLink Buckle

#### 4.1.8. Tools

Several tools are included for various scanner and accessory adjustments. (see *Included Tools on page 16*).

#### 4.1.9. Case

The system is provided with a rugged carrying case.

## 4.2. Compatible Components

### 4.2.1. Cable Management, Dovetail Mount CES044-

Cable management provides a means of protecting and organizing cables, tubes and hoses (Fig. 13).

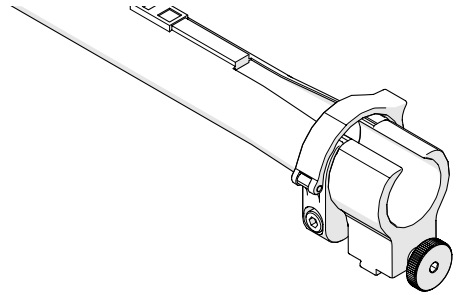

Fig. 13 - Cable management, dovetail mount

### 4.2.2. Encoder Adapter UMA010-

Adapt a scanner's existing encoder connector to a different encoder style (Fig. 14).

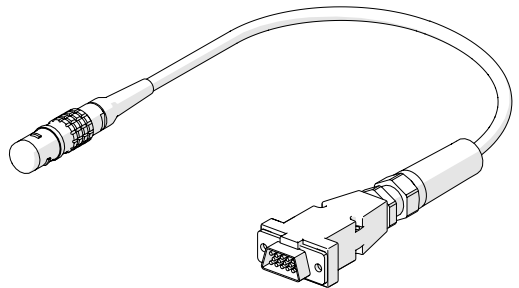

Fig. 14 - Encoder adapter

### 4.2.3. Preamp Bracket CES029-

A bracket that mounts to a scanner to hold various preamps (Fig. 15).

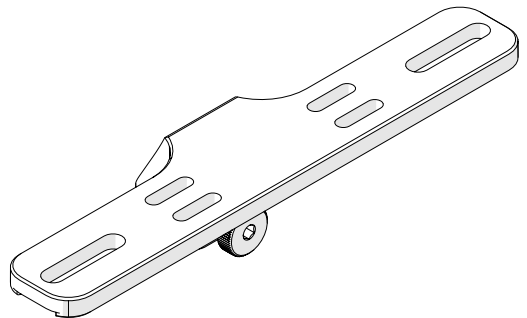

Fig. 15 - Preamp bracket

#### 4.2.4. Frame Bar BG0038-

Frame bars (*Fig. 16*) are used to mount probe holders, probe positioning systems and other accessories.

Frame bars are available in a variety of lengths.

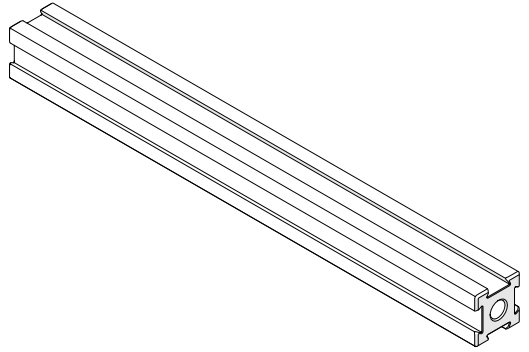

Fig. 16 - Frame bar

## 4.3. High Temperature Base System Components

### 4.3.1. HT Wheel Block with Handle CES071

The wheel block provides stability and to the **ROTIX** system and offers dovetail mounting points for accessories (*Fig. 17*).

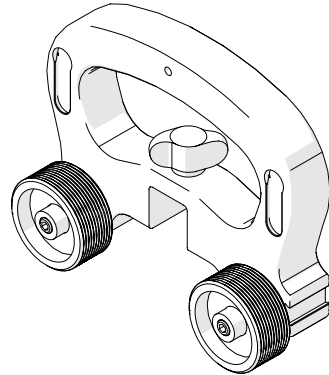

Fig. 17 - High temperature wheel block with handle

### 4.3.2. High Temperature Spring-Loaded Encoder BGS071-

The High Temperature Spring-Loaded Encoder mounts to any standard frame bar.

The spring-loaded encoder wheel operates on surfaces with a maximum temperature of 150°C (302°F) (*Fig. 18*).

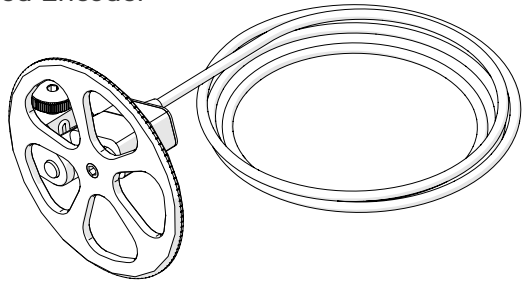

Fig. 18 - High temperature spring-loaded encoder

### 4.3.3. Slip Joint Probe Holder PHA012-

The slip joint probe holder is generally used during limited access inspection. The low profile design requires minimal radial clearance. The slip joint probe holder is designed to carry many different types of probes and wedges. It is available with various types of yokes, arms and pivot buttons (*Fig. 19*).

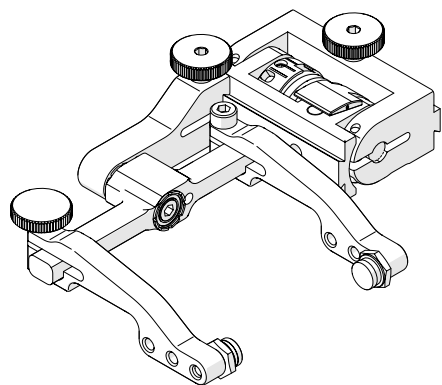

Fig. 19 - Slip joint probe holder

#### 4.3.4. High Temperature Standard Overtop Link CES107

The standard overtop link attaches to the double chain mount of the frame and reach overtop of the slip joint probe holders and connect to the QuickLinks (Fig. 20).

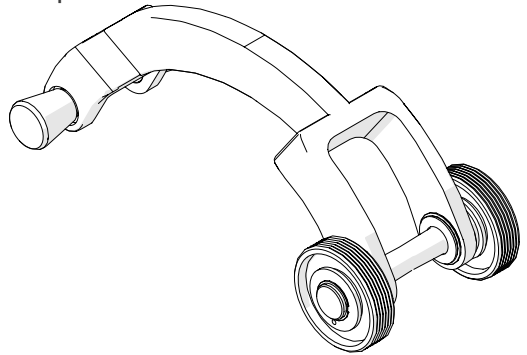

Fig. 20 - High temperature standard overtop link

#### 4.3.5. Frame Bar BG0038-

Frame bars provide a mount probe holders, probe positioning systems and other accessories.

Frame bars are available in a variety of lengths (Fig. 21).

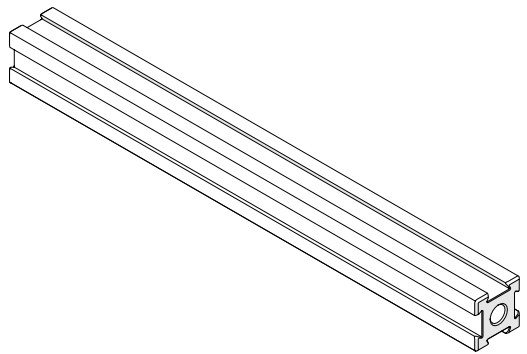

Fig. 21 - Frame bar

#### 4.3.6. Irrigation Kit CMG007

The irrigation kit provides a variety of hoses, fittings, connectors, and splitters commonly used during non-destructive inspection (Fig. 22).

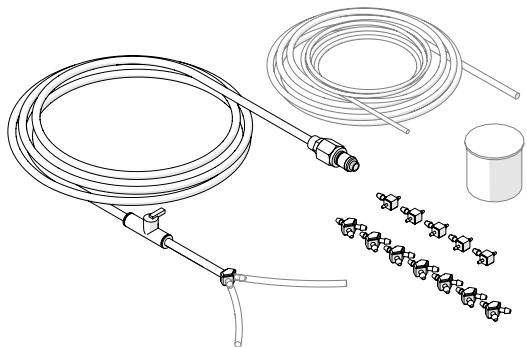

Fig. 22 - Irrigation kit

### 4.3.7. High Temperature Cable Management, Dovetail Mount CES089-

High temperature cable management provides a means of protecting and organizing cables, tubes and hoses (Fig. 23).

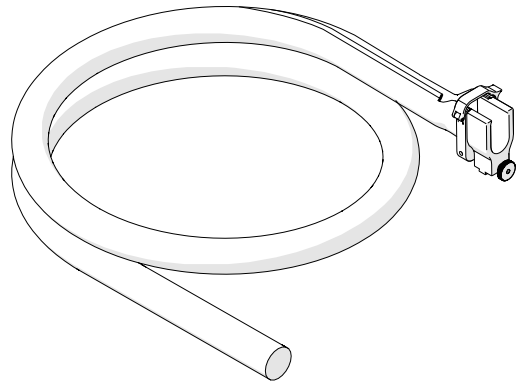

Fig. 23 - High temperature cable management, dovetail mount

### 4.3.8. Cable Clip BG0091

The Cable Clip provides a means of cable management. Place cables and hoses in the cable clip and then press the cable clip onto any scanner or frame bar's dovetail groove. (Fig. 24).

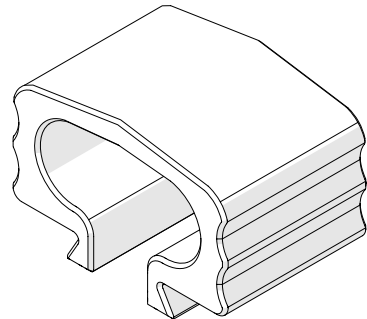

Fig. 24 - Cable clip

### 4.3.9. HT QuickLink Components

The QuickLink components fasten a ROTIX system circumferentially around a pipe or tube.

#### 4.3.9.1 High Temperature Dovetail QuickLink CES109

The Dovetail QuickLink connects to QuickLinks, providing a mounting point for accessories such as cable management (Fig. 11).

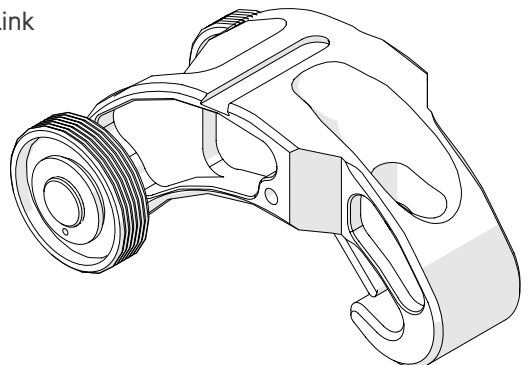

Fig. 25 - High temperature dovetail QuickLink

#### 4.3.9.2 High Temperature QuickLink Buckle CES108

The QuickLink Buckle enables adjustment of the chain tension and provides the connection point of the QuickLinks assembly (*Fig. 12*).

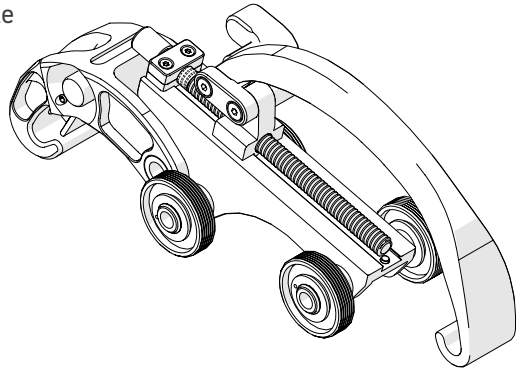

Fig. 26 - High temperature QuickLink buckle

#### 4.3.10. Tools

Several tools are included for various scanner and accessory adjustments. (*see Included Tools on page 16*).

#### 4.3.11. Case

The system is provided with a rugged carrying case.

## 4.4. Tools

### 4.4.1. Included Tools

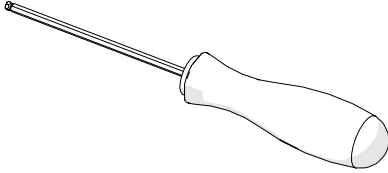

Fig. 27 - 3 mm hex driver

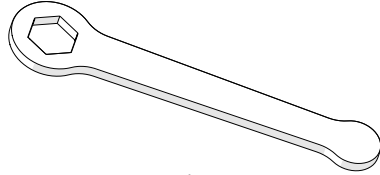

Fig. 28 - 3/8 in wrench

The 3 mm hex driver (*Fig. 27*) is sufficient for all typical operations and adjustments of the **ROTIX**.

The 3/8 in wrench (*Fig. 28*) removes and installs pivot buttons on the probe holders.

### 4.4.2. Optional tools

Some specialized adjustments require tools that are not included in this kit.

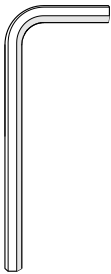

Fig. 29 - 1.5 mm hex wrench

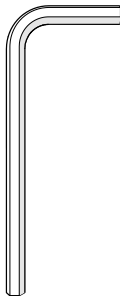

Fig. 30 - 2 mm hex wrench

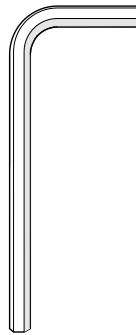

Fig. 31 - 3 mm hex wrench

# PREPARATION FOR USE

## 5.1. Configurations

### 5.1.1. Two Probe Scanning

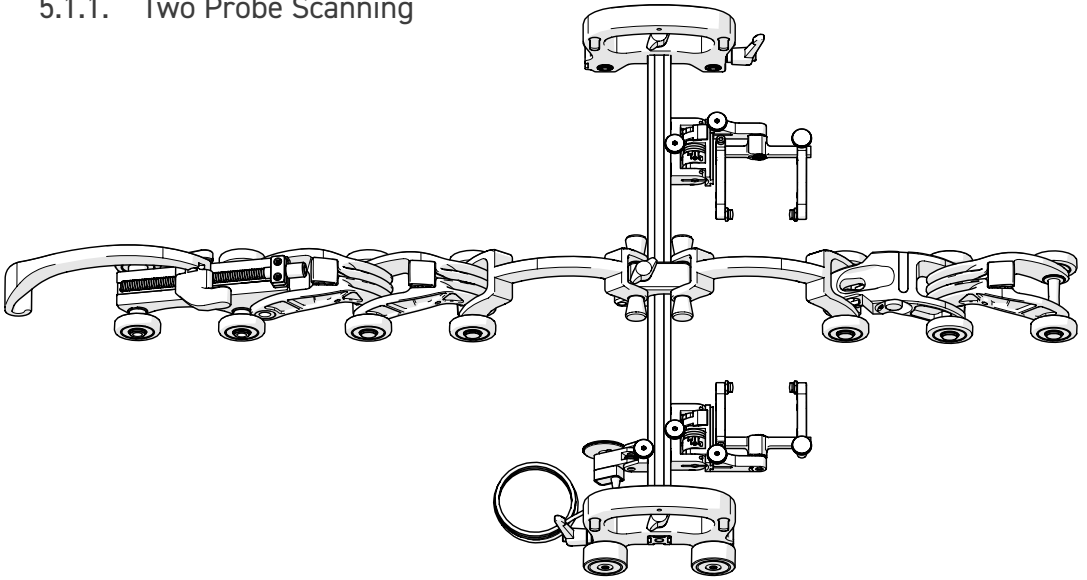

Fig. 32 - Two probe scanning

### 5.1.2. Four Probe Scanning

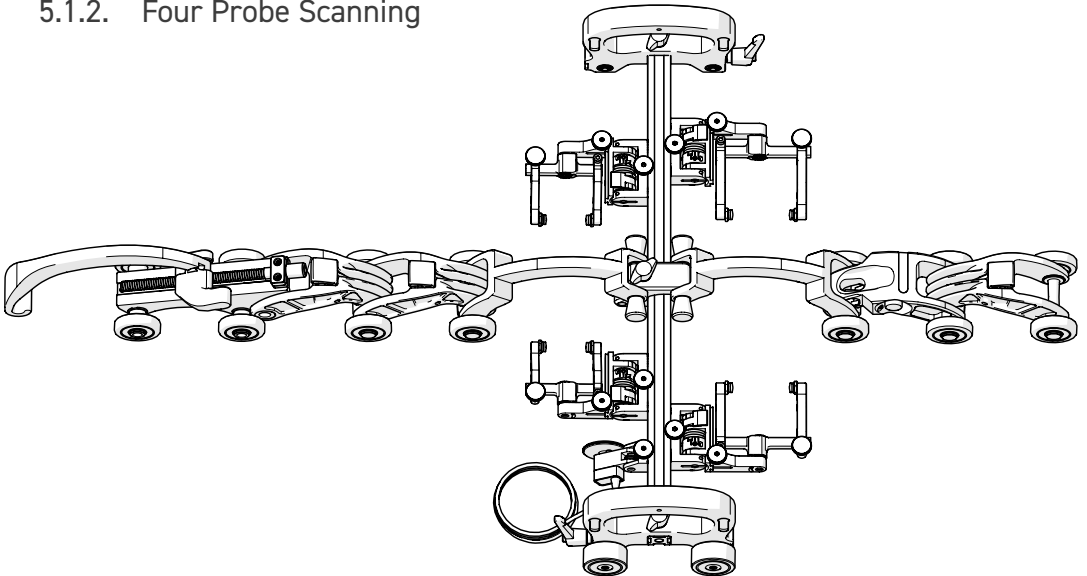

Fig. 33 - Four probe scanning

### 5.1.3. Four Probe Cantilever Scanning

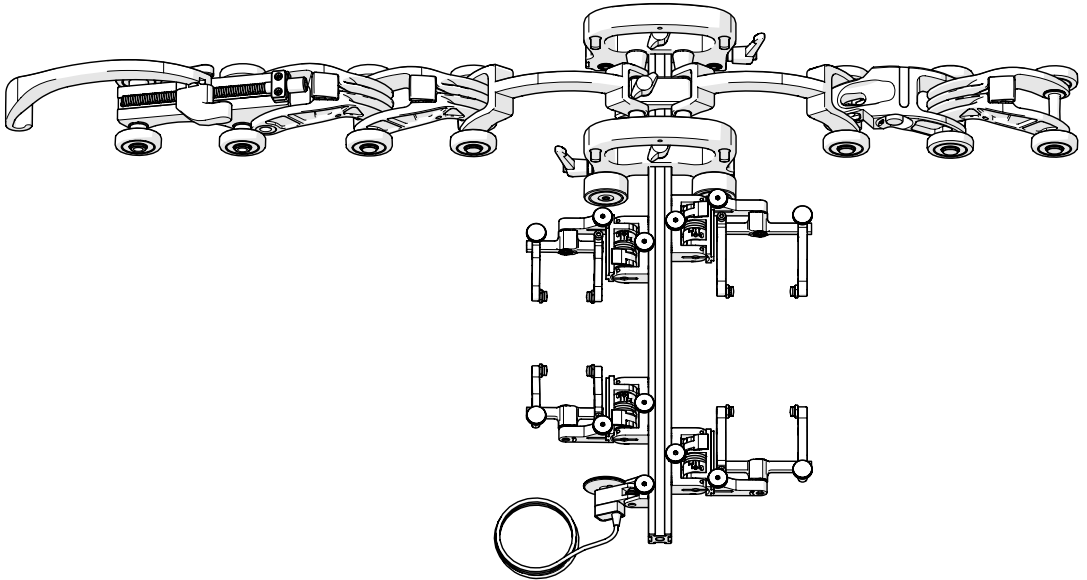

Fig. 34 - Four probe cantilever scanning

### 5.1.4. High Temperature Scanning

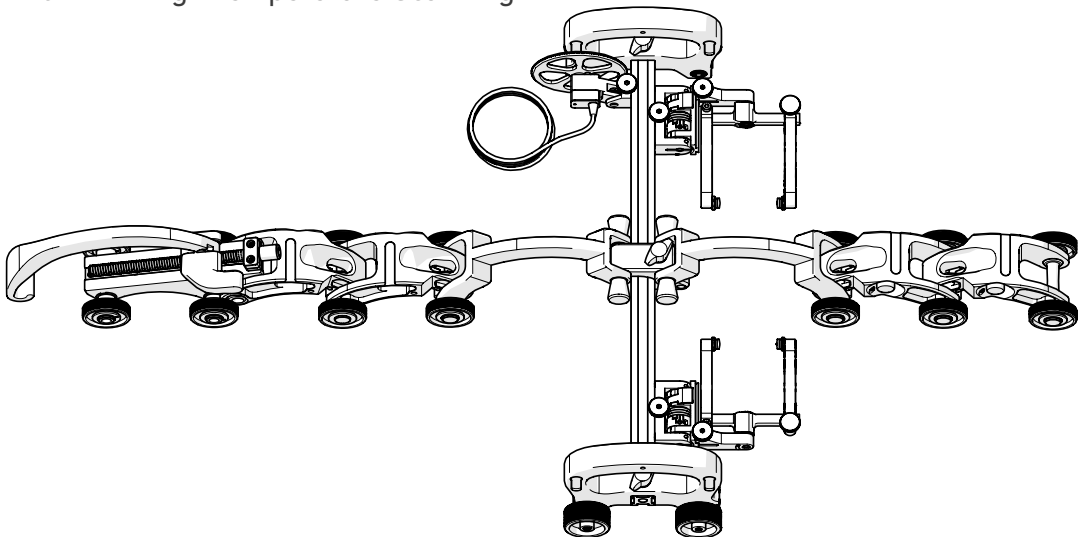

Fig. 35 - High temperature scanning

## 5.2. Wheel Block with Handle

### 5.2.1. Attaching a Frame Bar

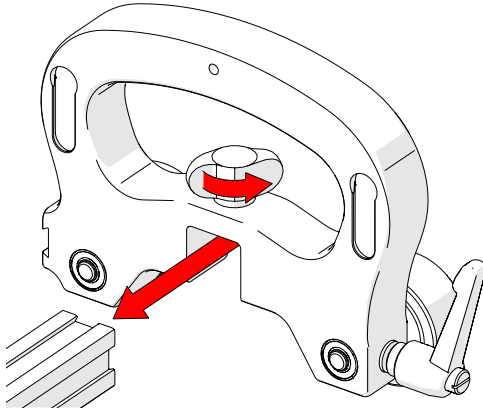

Fig. 36 - Attach to frame bar

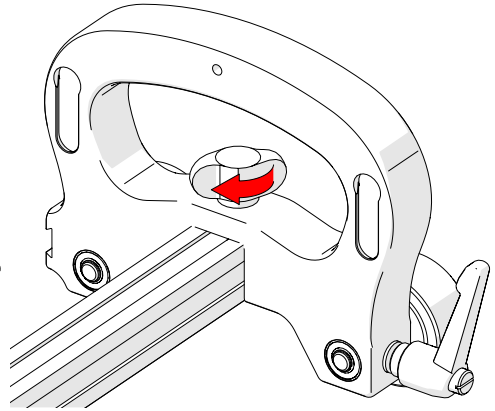

Fig. 37 - Tighten wing knob

Install the wheel block with handle by loosening the black wing knob and sliding the wheel block with handle's dovetail nut onto the frame bar (Fig. 36). Tighten the black wing knob (Fig. 37).

### 5.2.2. Wheel Removal/Installation

Tightly grip the wheel to be removed by hand. Loosen the wheel from the axle using the supplied 3 mm hex driver (Fig. 27).

**TIP:** When the brake is engaged, and the scanner is moved, this may loosen the wheels from the axle. Grip the wheel tightly and retighten the axle with the 3 mm hex driver.

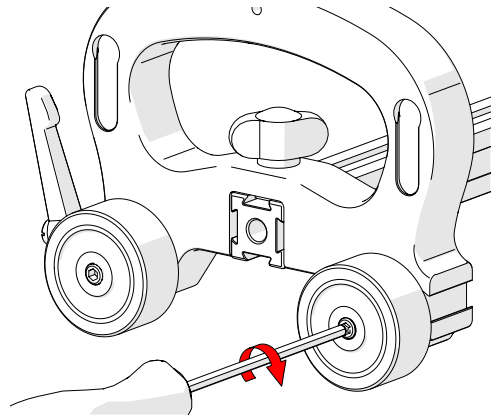

Fig. 38 - Wheel removal/installation

### 5.2.3. Brake

The ratchet lever located on the wheel block with handle operates the brake.

*(see Ratchet Lever on page 20 for additional details)*

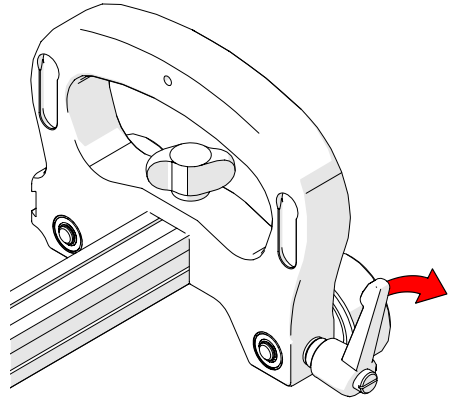

Fig. 39 - Wheel removal/installation

### 5.2.4. Ratchet Lever

The ratchet levers are used for braking functions on the **ROTIX** system. Occasionally, movement of the lever locking position is required. The lever placement can be adjusted by following these steps:

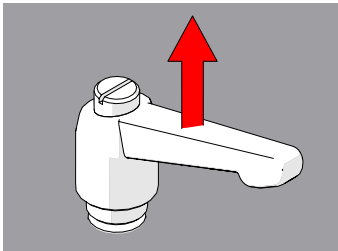

Fig. 40 - Pull ratchet handle

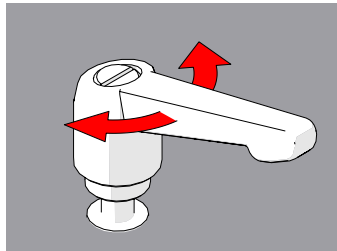

Fig. 41 - Rotate handle

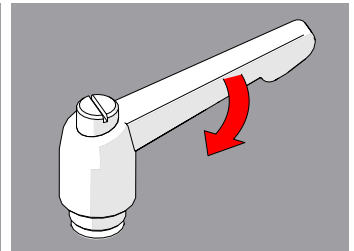

Fig. 42 - Tighten handle

1. Pull the ratchet lever away from the base to which it is connected (*Fig. 40*).
2. Continue to pull while rotating the lever in the appropriate direction (*Fig. 41*).
3. Release the lever and utilize the new tightening position.

### 5.2.5. Dovetail Grooves

The dovetail grooves on the wheel block with handle are used to mount various accessories and components.

**NOTE:** The spring-loaded encoder can NOT be mounted to the wheel block with handle when the diameter of the scan surface is less than 30.4 cm (12 in).

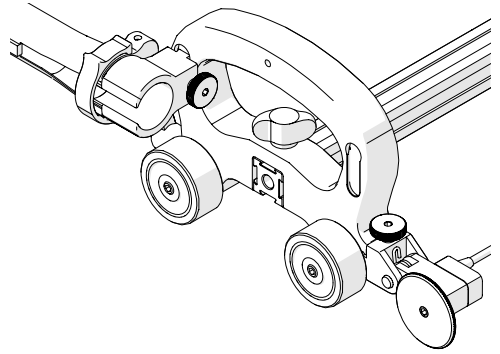

Fig. 43 - Dovetail mounts

### 5.3. Double Chain Mount

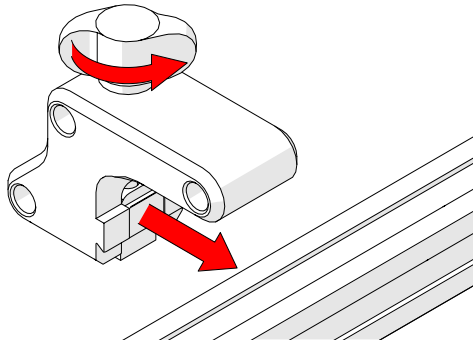

Fig. 44 - Chain mount

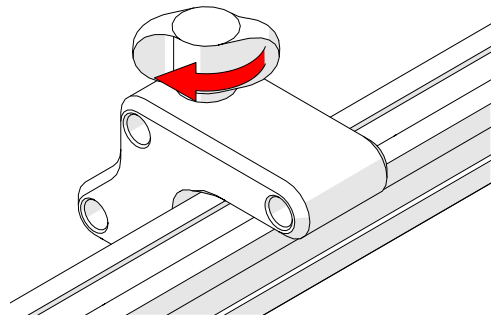

Fig. 45 - Chain mount alignment

The double chain mount provides a connection point for connector links.

1. Loosen the double chain mount's dovetail jaw using the black wing knob (Fig. 44).
2. Secure the double chain mount to the frame bar by tightening the black wing knob. (Fig. 45).

The lower hole of the double chain mount is used to connect the chain during two probe scanning. When scanning with four probes (requiring two connector links), always connect the connector links to the top holes of the double chain mount.

## 5.4. Connecting QuickLinks & Dovetail Links

### 5.4.1. Connecting QuickLinks

To connect QuickLinks, see the following steps:

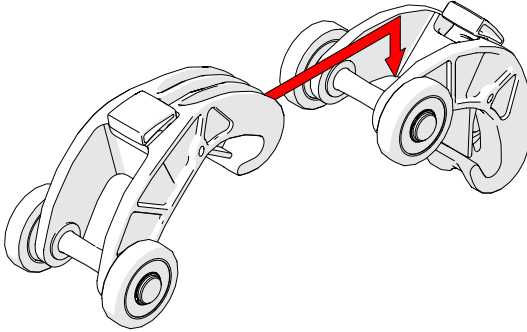

Fig. 46 - Lift the hook over the axle of the QuickLink

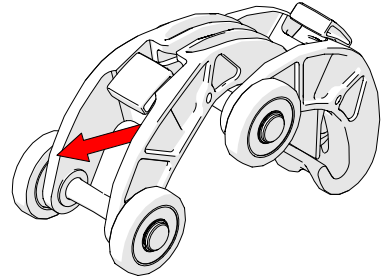

Fig. 47 - Pull the link backwards to secure catch

1. Lift the hook of the QuickLink over the axle of the QuickLink that is to be connected (Fig. 46).
2. Pull the QuickLink until you hear a click that ensures the latch has been set (Fig. 47).

### 5.4.2. Disconnecting QuickLinks

To disconnect QuickLinks, see the following steps:

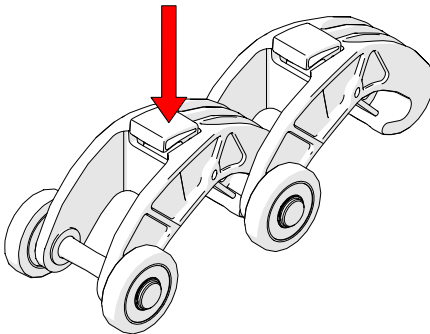

Fig. 48 - Press button

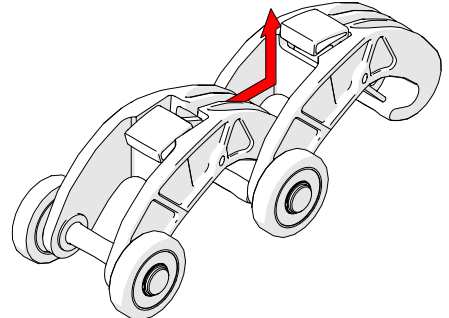

Fig. 49 - Slide QuickLink forward and lift

1. Press the button on the top of the QuickLink (Fig. 48).
2. While pressing the button, slide the QuickLink forward and up, clearing the hook of the QuickLink from the 2<sup>nd</sup> QuickLink's axle (Fig. 49).

### 5.4.3. Disconnecting the Dovetail QuickLink

To disconnect Dovetail QuickLinks, see the following steps:

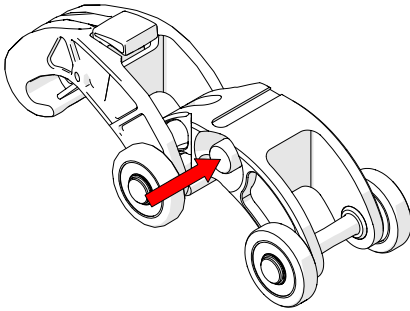

Fig. 50 - Press red button

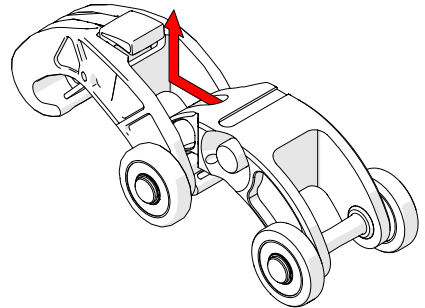

Fig. 51 - Slide Dovetail QuickLink forward and lift

1. Press the button on the side of the Dovetail QuickLink (Fig. 50).
2. While pressing the red button, slide the Dovetail QuickLink forward and up, clearing the hook of the Dovetail QuickLink from the 2<sup>nd</sup> QuickLink's axle (Fig. 51).

### 5.4.4. Attaching Connector Link

1. Pull the pins and twist a quarter turn latching the pins in a retracted state (Fig. 52).

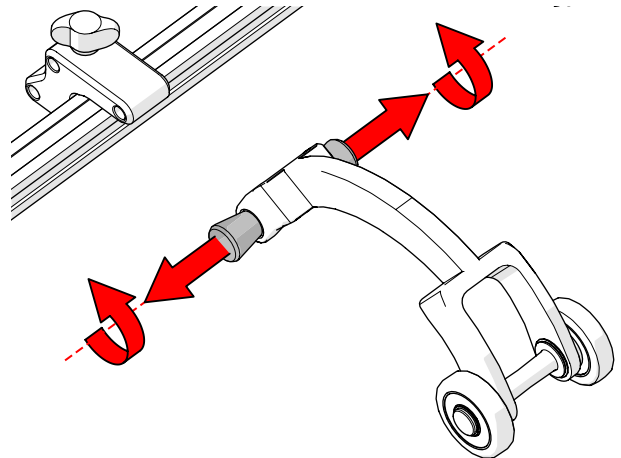

Fig. 52 - Pull pins and twist

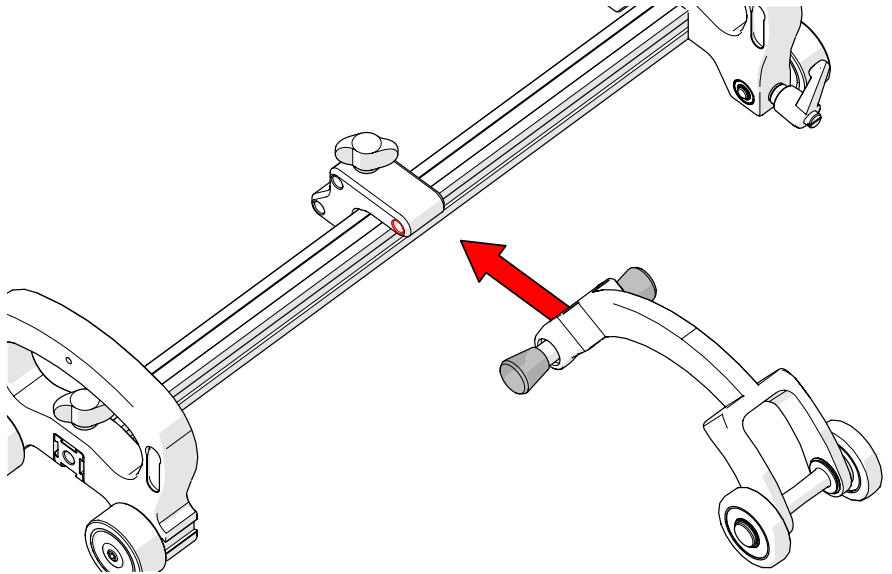

Fig. 53 - Align pins with mounting holes

2. Align the pins with the mounting holes of the double chain mount (Fig. 53).

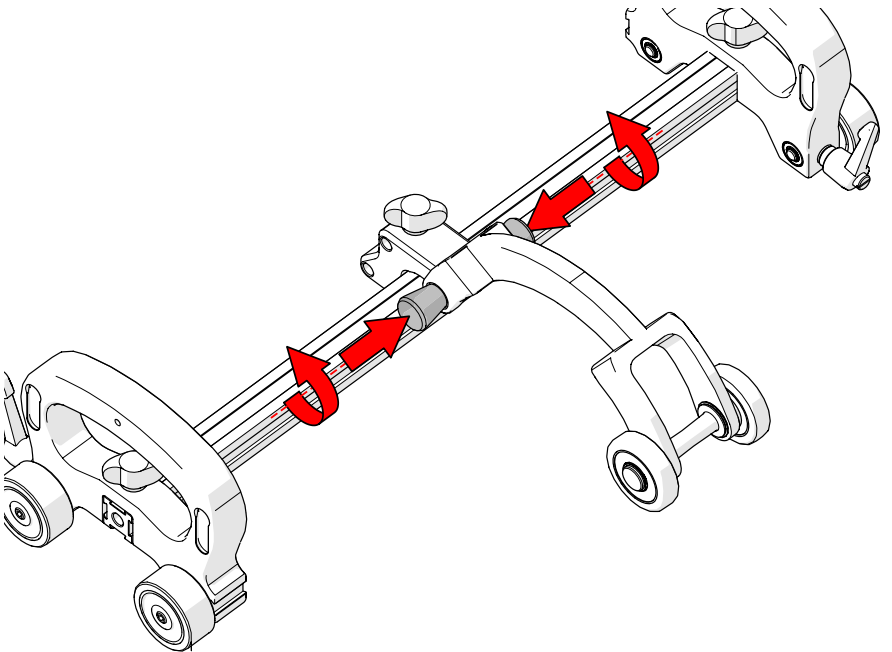

Fig. 54 - Twist pins to unlatch and connect

3. Twist the pins until they unlatch and extend into the connection holes of the double chain mount (Fig. 54).

## 5.5. Cable Clips

Clips have been provided to assist with cable management. Pinch the clip and press it into the dovetail groove of the frame bar.

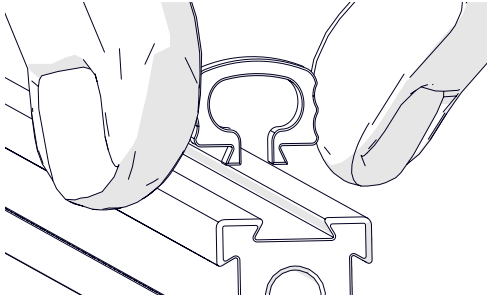

Fig. 55 - Pinch clip

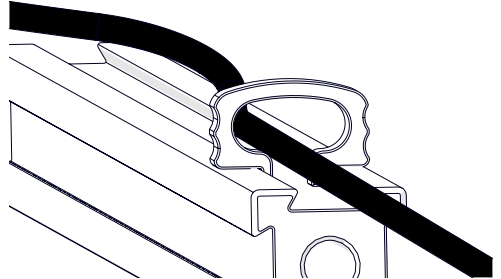

Fig. 56 - Route cables

## 5.6. Spring-Loaded Encoder

To install the encoder, follow these steps:

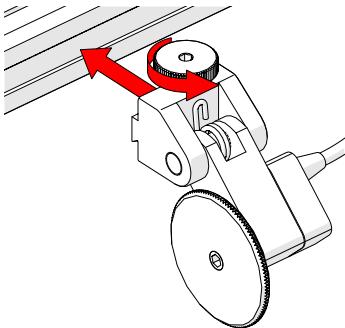

Fig. 57 - Attach to frame bar

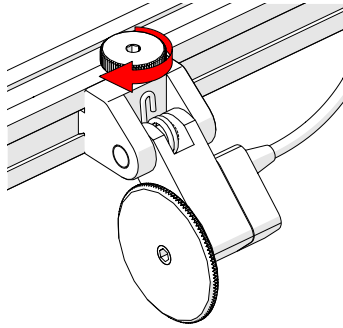

Fig. 58 - Tighten knob

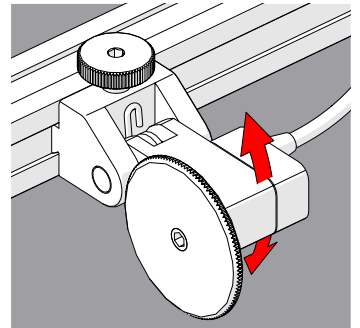

Fig. 59 - Place on scan surface

1. Loosen the encoder's dovetail jaw and mount it to the frame bar (Fig. 57).
2. Tighten the encoder knob (Fig. 58).
3. Spring tension maintains encoder contact with the scan surface (Fig. 59).

**NOTE:** The spring-loaded encoder can NOT be mounted to the wheel block with handle when the diameter of the scan surface is less than 30.4 cm (12 in).

## 5.7. Frame Bar

Frame bars (*Fig. 60*) are used to mount probe holders, probe positioning systems and other accessories (see *Frame Bars on page 54*).

Frame bars are available in a variety of lengths.

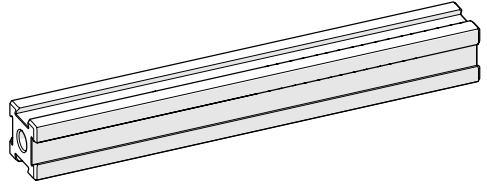
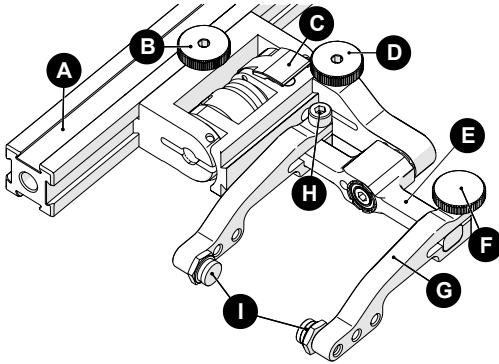

Fig. 60 - Frame bar

## 5.8. Slip Joint Probe Holder



A	Frame Bar
B	Probe Holder Adjustment Knob
C	Latch
D	Swing Arm Knob
E	Yoke
F	Probe Holder Arm Adjustment Knob
G	Probe Holder Arm
H	Arm Clamp Screw
I	Pivot Buttons

Fig. 61 - Slip Joint Probe Holder

### 5.8.1. Probe Holder Setup

To mount a UT wedge in the probe holder, follow these steps:

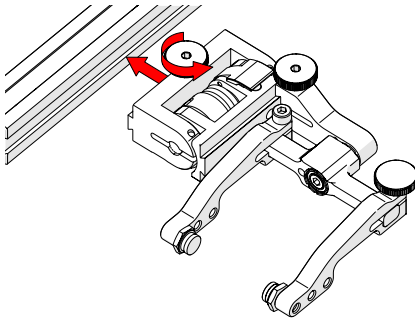

Fig. 62 - Attach to frame bar

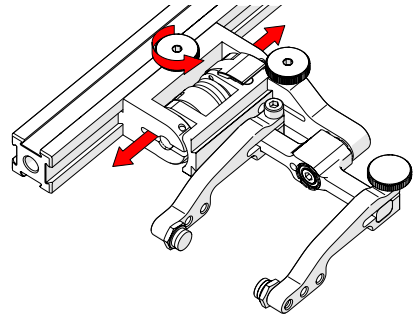

Fig. 63 - Adjust on frame bar

1. Rotate the probe holder adjustment knob and attach the probe holder to a frame bar (Fig. 62).
2. Use the probe holder adjustment knob to position the probe holder along the frame bar (Fig. 63).

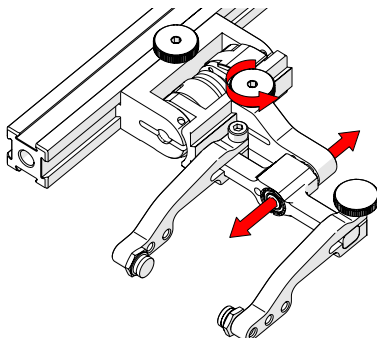

Fig. 64 - Adjust swing arm

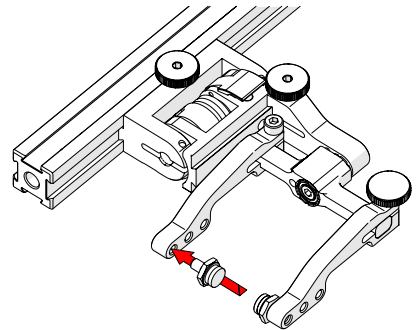

Fig. 65 - Place pivot buttons

3. Use the swing arm knob to position the swing arm (Fig. 64).

**TIP:** The swing arm is typically used to adjust TOFD center-to-center distance relative to the phased array probes on a four probe configuration (Fig. 33).

4. Using the supplied 3/8 in wrench (Fig. 28), place the pivot buttons as required (Fig. 65).

**TIP:** If narrow scanning footprint is required, use pivot button holes closest to the yoke. Wedge pivoting may be impeded when closer to the yoke.

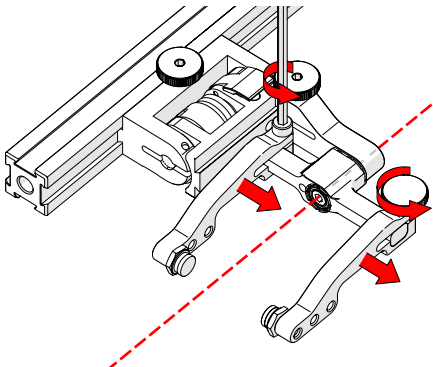

Fig. 66 - Adjust probe holder arms

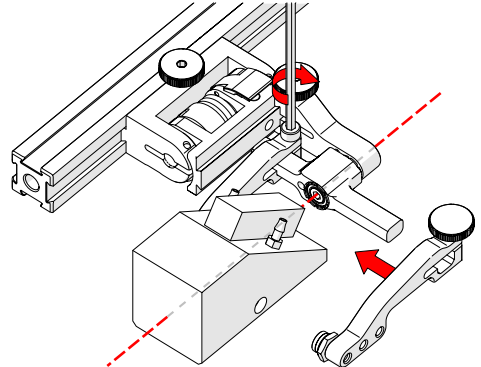

Fig. 67 - Place wedge

5. Loosen the probe holder arm adjustment knob (Fig. 66) and remove the outer probe holder arm from yoke.
6. Adjust the inner probe holder arm as required to best centre the probe on the yoke's pivot axis (Fig. 66).

**TIP:** The probe holder yoke can accommodate many different probe and wedge sizes of varying widths. When scanning, it is best to centre the wedge with the yoke's pivot axis to reduce wedge tipping. Position the inner probe holder arm accordingly with the centre of the yoke (Fig. 66).

7. Position the wedge on the inner probe holder arm (Fig. 67).
8. Slide the outer probe holder arm along the yoke pinching the wedge in place.
9. Tighten the probe holder arm adjustment knob (Fig. 68).

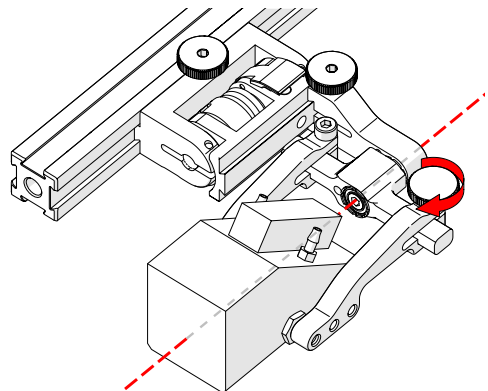

Fig. 68 - Pinch wedge with arm

## 5.8.2. Probe Holder Adjustment

To adjust the probe holder, follow these steps:

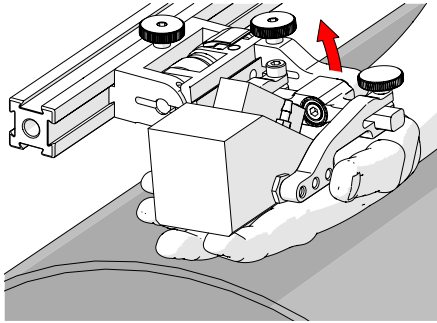

Fig. 69 - Lift to latched position

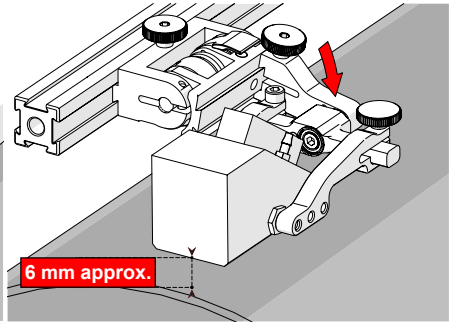

Fig. 70 - Lower to scanning surface

1. Ensure the probe holder is in the latched, upper position (Fig. 69). If the probe holder is already latched, it will only move within the slip joint adjustment range and have no spring tension.
2. Push the probe holder yoke down toward the inspection surface until the wedge is approximately 6 mm ( $\frac{1}{4}$  in) above the inspection surface (Fig. 70).

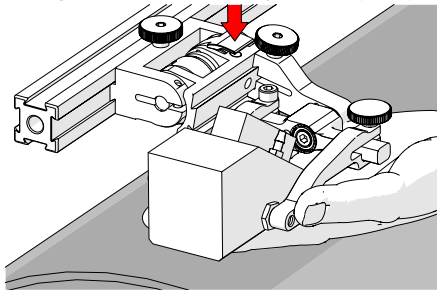

Fig. 71 - Lift and press latch button

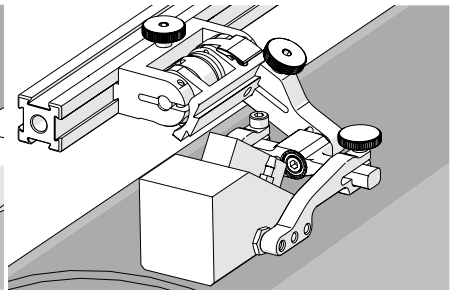

Fig. 72 - Spring-loaded scan position

3. Lift the probe slightly and press the latch button (Fig. 71) to apply spring pressure to the wedge.
4. Gently lower probe holder and wedge to the scanning surface (Fig. 72).

## 5.8.3. Probe Holder Force Adjustment

It is possible to adjust the tension of the probe holder spring.

**NOTE:** The 2 mm hex wrench (Fig. 30) and 3 mm hex wrench (Fig. 31) are required to perform this operation.

Light	1 kg	2 lb
Medium	2 kg	4 lb
Heavy	3 kg	6 lb

When configured correctly, these settings exert the indicated spring force on the Probe.

To adjust the probe holder's force, follow these steps:

**NOTE:** Do not perform this operation on a scanning surface.

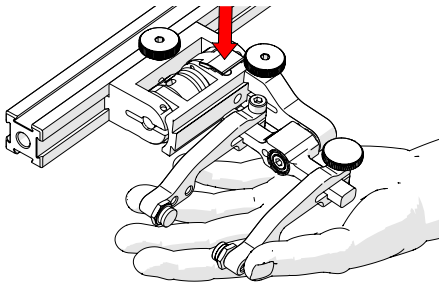

Fig. 73 - Lift slightly and press latch

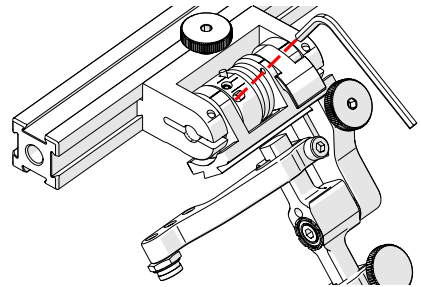

Fig. 74 - Unlatched position

1. Ensure the probe holder is in the upright latched position (Fig. 69).
2. Lift the probe holder slightly and press the latch button (Fig. 73) to release the probe holder to the full 45° degrees.
3. Insert the short arm of a 3 mm hex wrench into the 3 mm slot (Fig. 74).

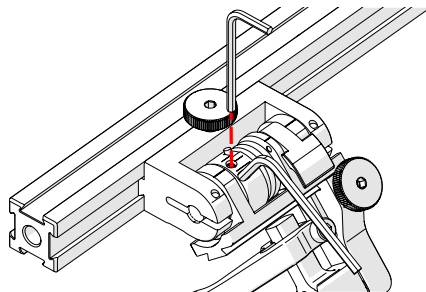

Fig. 75 - Insert hex wrenches

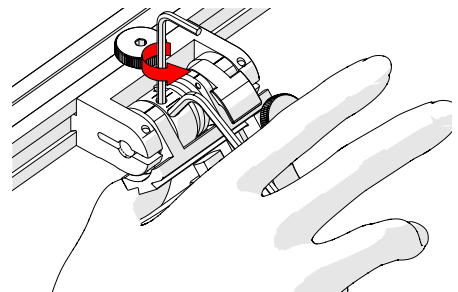

Fig. 76 - Press 3 mm hex wrench down

4. Place the 2 mm hex wrench into the force adjustment screw (Fig. 75).
5. Lightly press the long arm of the 3 mm hex wrench down. Using the 2 mm hex wrench, loosen the force adjustment screw but do not remove it (Fig. 76).
6. Gently apply pressure on the long leg of the 3 mm hex wrench until the force adjustment marker lines up with the desired spring tension. While keeping the markers in line, tighten the force adjustment screw (Fig. 77).

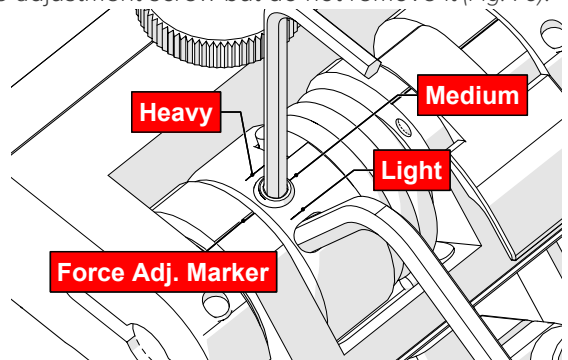

Fig. 77 - Choose desired tension

### 5.8.4. Slip Joint Probe Holder Left/Right Conversion

To reverse the probe holder, follow these steps:

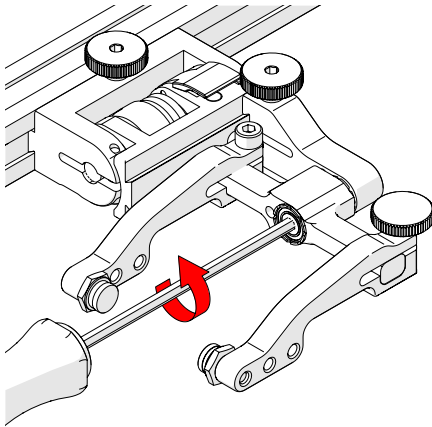

Fig. 78 - Unscrew yoke pivot screw

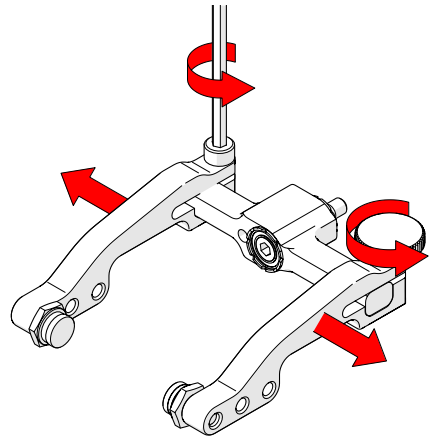

Fig. 79 - Remove arms

1. Unscrew the yoke from the swing arm (Fig. 78).
2. Loosen the probe holder arm adjustment knob and arm clamp screw. Slide the arms from the yoke (Fig. 79).

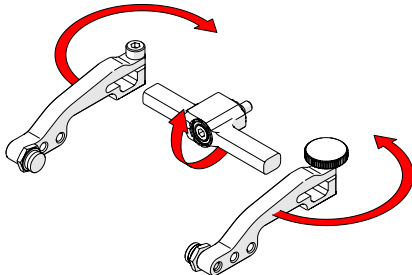

Fig. 80 - Flip yoke and reverse arms

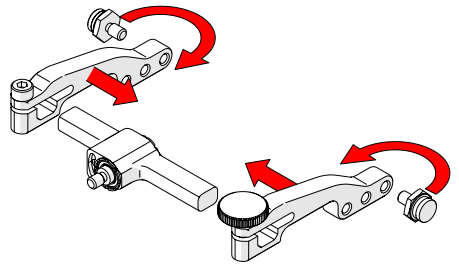

Fig. 81 - Attach arms and move buttons

3. Flip the yoke 180° and reverse the probe holder arms (Fig. 80).
4. Place the pivot buttons on the inside of the probe holder arms (Fig. 81) using a 3/8 in wrench (Fig. 28). Slide the arms onto the yoke and tighten the probe holder arm adjustment knob and the arm clamp screw.

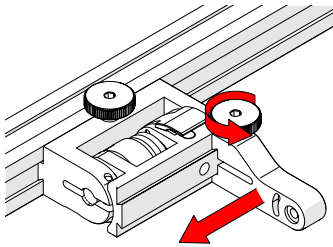

Fig. 82 - Position swing arm

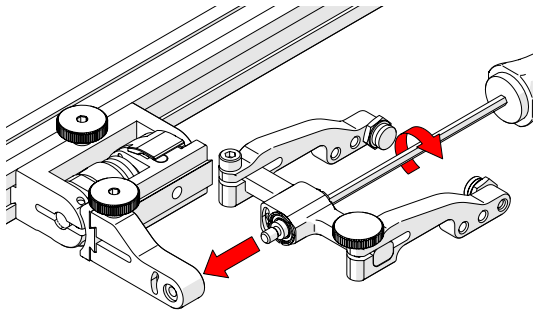

Fig. 83 - Install yoke to swing arm

5. Loosen the swing arm knob and slide the swing arm to the opposite end of the probe holder bracket (Fig. 82) or the preferred position. Tighten the swing arm knob.
6. Using the 3 mm hex driver, screw the yoke pivot screw into the opposite side of the probe holder swing arm (Fig. 83). Ensure the yoke is level to avoid issues with the plunger/set screw.

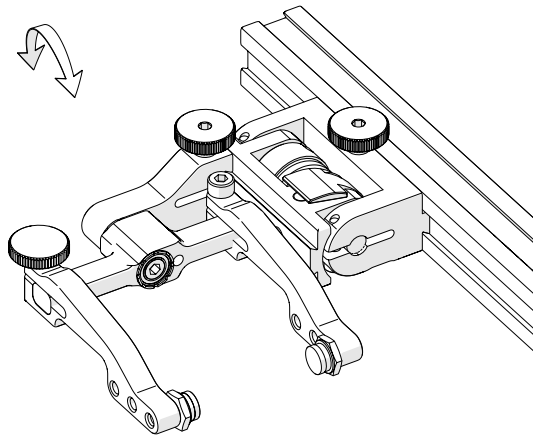

Fig. 84 - Reversed probe holder

### 5.8.5. Pivot Buttons

Available in a variety of shapes and sizes, fitting various wedge dimensions.

Use the supplied 3/8 in wrench (Fig. 28) to remove and install pivot buttons (Fig. 85).

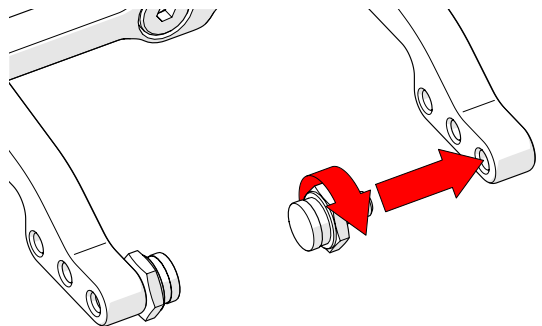

Fig. 85 - Pivot buttons

## 5.9. Cable Management System

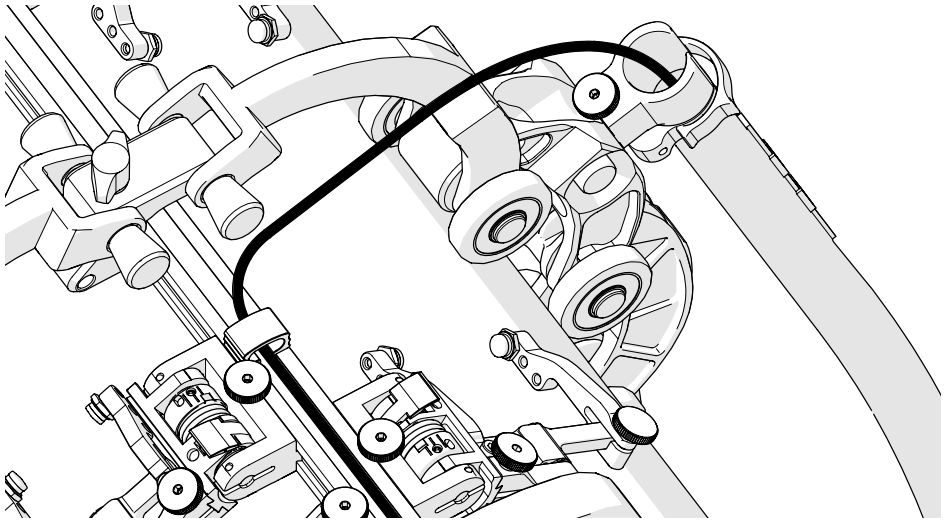

Fig. 86 - Cable management

**TIP:** When using cable management, ensure the dovetail link is placed 2<sup>nd</sup> in the chain behind the adjustable overtop link.

### 5.9.1. Cable Management Dovetail Mount

To attach cable management, follow these steps:

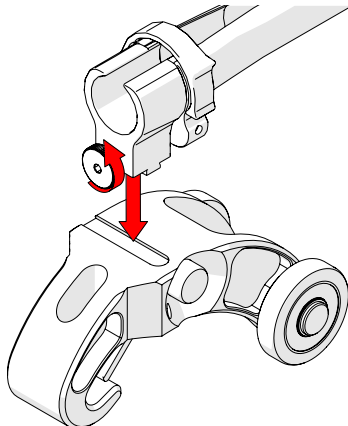

Fig. 87 - Loosen and slide on

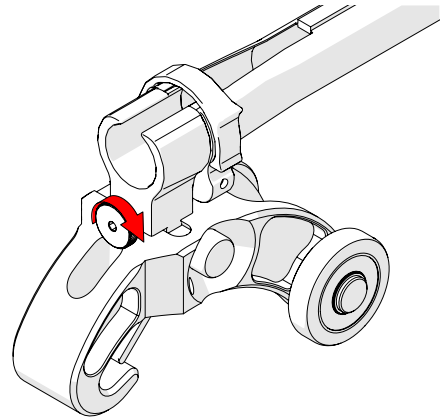

Fig. 88 - Tighten knob

1. Loosen the knob on the cable management dovetail mount. Position the mount onto the Dovetail QuickLink (Fig. 87).
2. Once centred on the Dovetail QuickLink, tighten the cable management's dovetail mount knob (Fig. 88).

## 5.9.2. Cable Management Setup

The cable management is available in a variety of lengths and provides a means of bundling and protecting cables and hoses that run to the scanner.

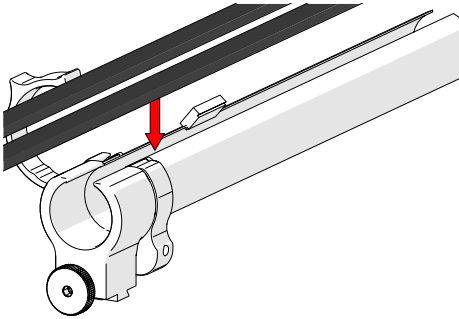

Fig. 89 - Insert cables and hoses

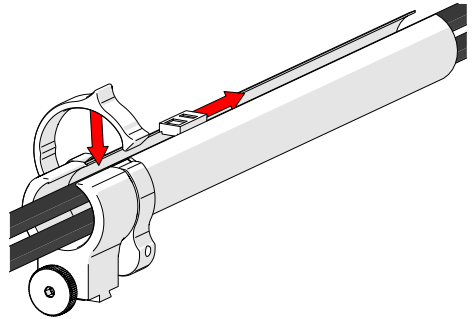

Fig. 90 - Zip up to close

1. Open the cable management. Begin at the tube's dovetail mount and place the cabling in the tube (*Fig. 89*).
2. Follow the cable placement, zipping the tube closed (*Fig. 90*).

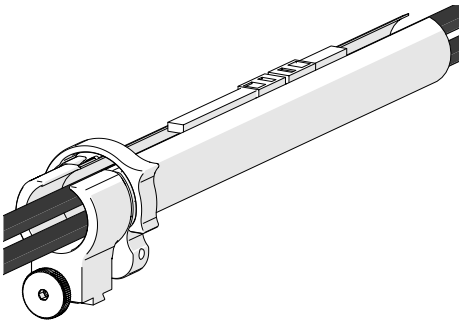

Fig. 91 - Zip opposite end

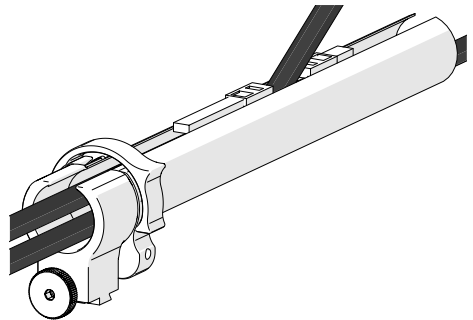

Fig. 92 - Flexibility

3. Once the cable is placed the entire length of the tube, bring the zipper from the tube's opposite end, meeting at any point in the middle (*Fig. 91*).
4. When necessary, the two zippers may be opened to allow cables to exit the tube anywhere between the ends (*Fig. 92*).

### 5.9.3. Clamp Setup

If the tube becomes disconnected from the cable management dovetail mount, follow these instructions to re-attach the tube and dovetail mount.

1. Loosen the clamp screw using the supplied 3 mm hex driver.
2. Slide the clamp around the tube first and then slide the tube around the outside of the cable management dovetail mount (*Fig. 93*). Align the zipper opening and the cable management dovetail mount opening.
3. Slide the clamp over the tube and cable management dovetail mount, pinching the tube in between (*Fig. 94*).
4. Tighten the clamp screw (*Fig. 95*).

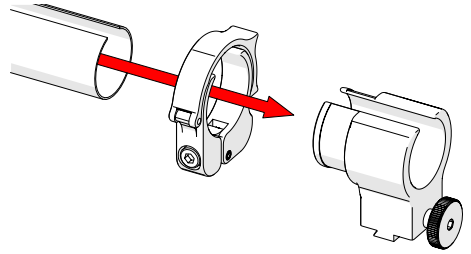

Fig. 93 - Slide tube around mount

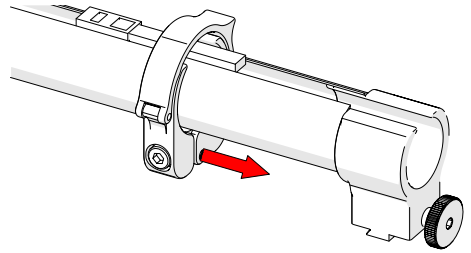

Fig. 94 - Slide clamp onto mount

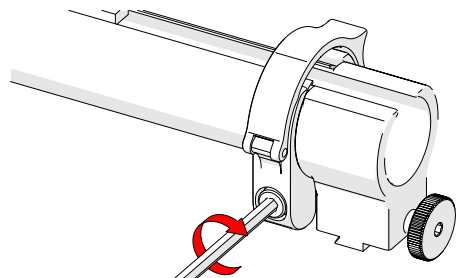

Fig. 95 - Tighten clamp screw

## 5.10. High Temperature Weld Frame Scanner



**WARNING! EXTREME HEAT.** Use high temperature gloves capable of protection up to 150°C (302°F). Take all precautions to protect hands and body from hot inspection surface.

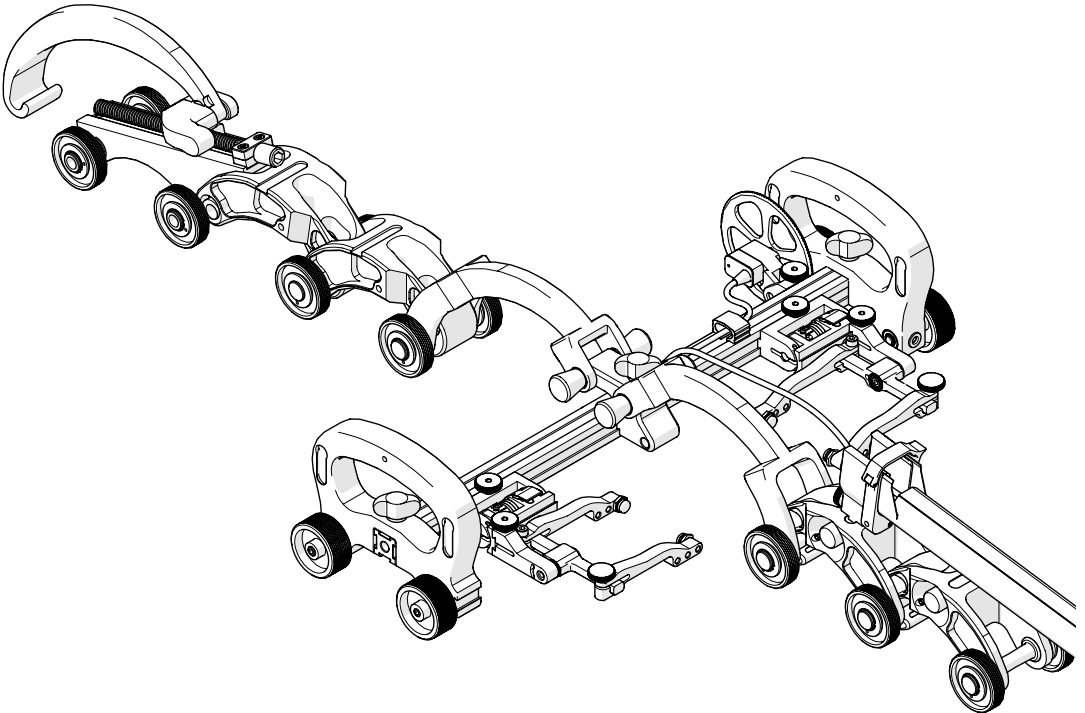

Fig. 96 - ROTIX - High temperature weld frame scanner

The high temperature weld frame scanner can be used on surfaces with a temperature of up to 150°C (302°F). The components of the high temperature scanner are similar to those of the standard weld frame scanner. As such, the instructions for using the high temperature kit are the same as those found in this user manual.

**NOTE:** Do **NOT** substitute or use any links, wheel blocks, encoder or cable management from the standard weld frame components.

## 5.11. Magnetic Wheel Kit



**WARNING! MAGNETIC MATERIAL.** The magnetic wheel kit produce a magnetic field which may cause failure or permanent damage to items such as watches, memory devices, CRT monitors, medical devices or other electronics. People with pacemakers or ICD's must stay at least 25 cm (10 in) away.

When using a chain scanner is not appropriate, the magnetic wheel kit (Fig. 97) can replace the urethane wheels on a **ROTIX** scanner body. Two sets of magnetic wheel kits can also be used on the scanner body to double the magnetic force.

To install or remove wheels (see *Wheel Block with Handle on page 19*).

**NOTE:** Do not use magnetic wheels with a chain assembly.

**NOTE:** Magnetic wheels may lose their magnetic properties if heated above 175°F (80°C).

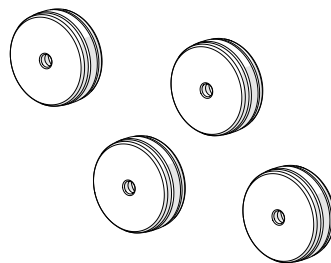

Fig. 97 - Magnetic wheel kit

## 5.12. Preamp Bracket

Compatible with most standard preamps, use screws or the optional velcro straps to attach a preamp to the preamp bracket.

Intended Use

- ▶ The preamp bracket is intended to mount objects (*e.g. preamps, splitters, etc.*) that:
- ▶ have a maximum weight of 1.36 kg (3 lb)
- ▶ are attached to the with a lanyard or probe cables strong enough to prevent the object from falling
- ▶ have smooth edges so as not to cut the bracket's velcro strap

**NOTE:** Not compatible with the high temperature kit.

### 5.12.1. Mounting Preamp Bracket

The preamp bracket mounts to any dovetail groove.

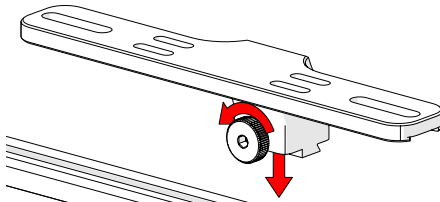

Fig. 98 - Loosen knob and mount to dovetail groove

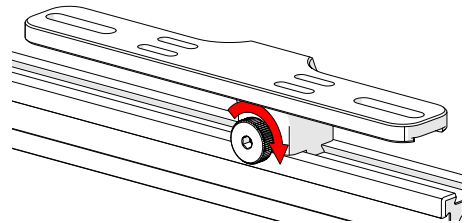

Fig. 99 - Tighten knob

1. Loosen the knob and align dovetail nut with the dovetail groove (*Fig. 98*).
2. Tighten the knob to lock the preamp bracket in place (*Fig. 99*).

### 5.12.2. Attaching Preamp with Screws

Use the adjustable screw mounting channel on the bottom of the bracket to attach a preamp (*screws not included*).

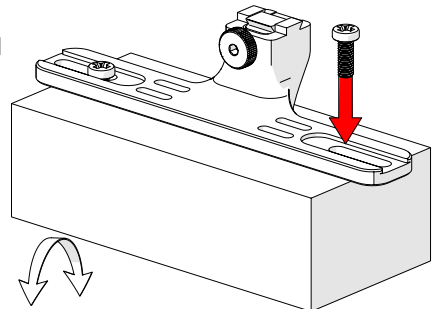

Fig. 100 - Attach preamp with screws

### 5.12.3. Attaching Preamp with Velcro Straps

To attach the preamp to the bracket using velcro straps (*sold separately*), follow these steps:

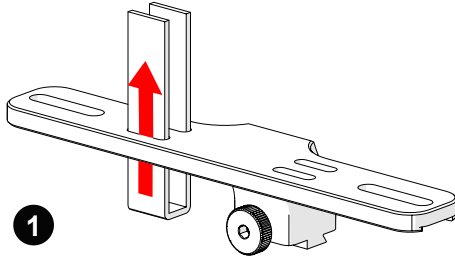

Fig. 101 - Insert velcro straps

1. Slide the velcro strap through the bracket's holes (*Fig. 101*).
2. Centre and place the preamp on the bracket wrapping the velcro around the preamp (*Fig. 102*).
3. Secure the preamp to the bracket attaching each side of the velcro (*Fig. 103*).

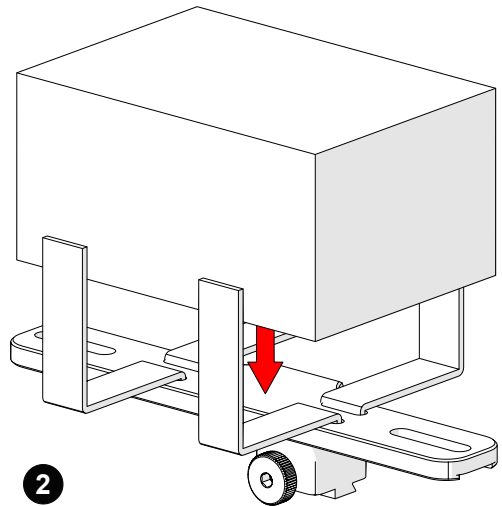

Fig. 102 - Place preamp and wrap velcro

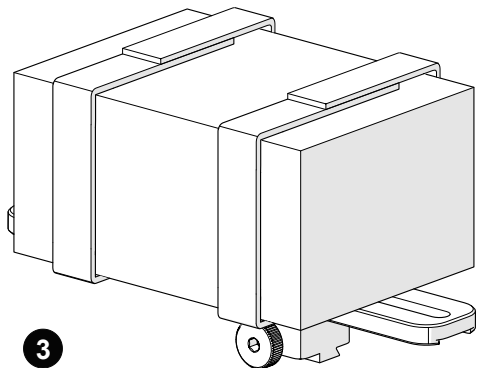

Fig. 103 - Mount bracket on a frame bar

# OPERATION

## 6.1. Setup of ROTIX on a Scanning Surface

1. Determine the diameter of the pipe or tube to be scanned. The **ROTIX** kit and this manual include two setup charts indicating the number of links required based on the pipe diameter or tubing (Fig. 104). Refer to the appropriate chart based on the number of probes to be used when scanning.

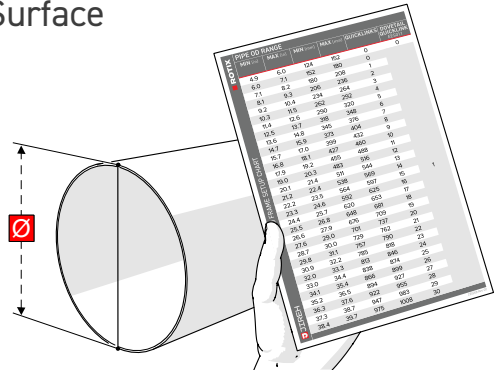

Fig. 104 - Refer to setup chart

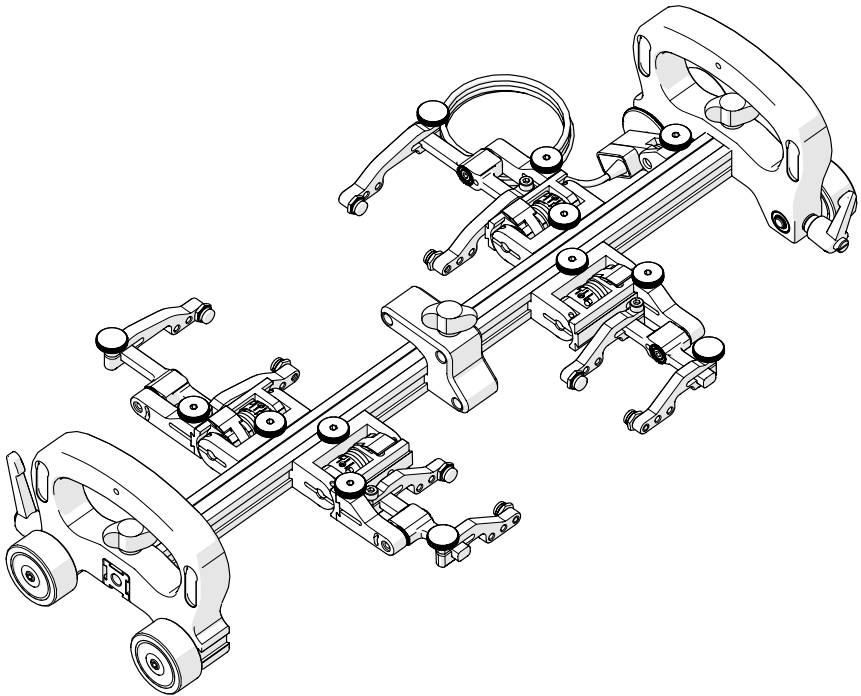

Fig. 105 - Assemble configuration

2. Assemble the appropriate configuration to the frame bar (Fig. 105). Install the wedge and probes that will be used (see Slip Joint Probe Holder on page 27).

**TIP:** The following example is a four probe configuration for a 30.4 cm (12 in) pipe diameter.

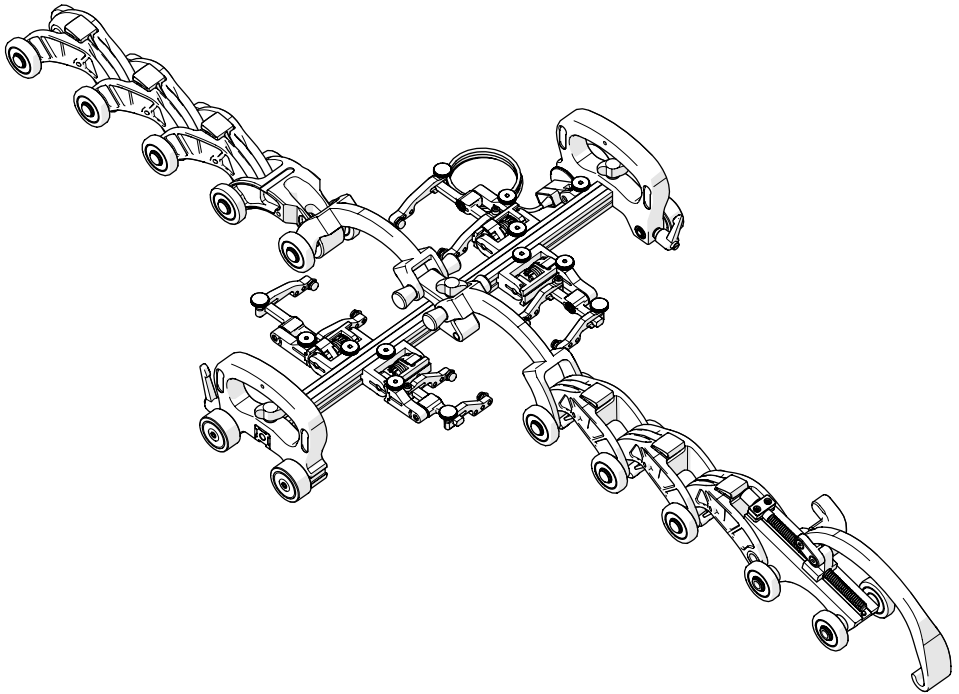

Fig. 106 - Assemble configuration

3. On a flat surface, connect the appropriate number of links (see *Connecting QuickLinks on page 22*) as indicated on the **ROTIX** setup chart. Arrange the link setup so the buckle and catch link will be 180° opposite the scanner body (Fig. 106).

**TIP:** Place the dovetail link 2<sup>nd</sup> in the chain after the adjustable overtop link.

4. Ensure the wheel block with handle brakes are locked (see *Wheel Block with Handle on page 19*).
5. Drape the configured assembly around the pipe/tube to be inspected (Fig. 107). Ensure the scanner's double wheel chain links straddle the weld.

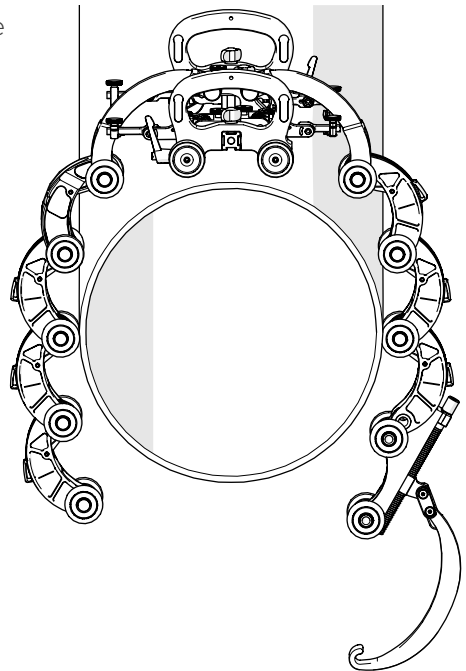

Fig. 107 - Place on pipe

6. Bring the QuickLink Buckle's arm towards the opposite QuickLink. Hook the QuickLink Buckle's arm to the middle axle of the QuickLink (Fig. 108).

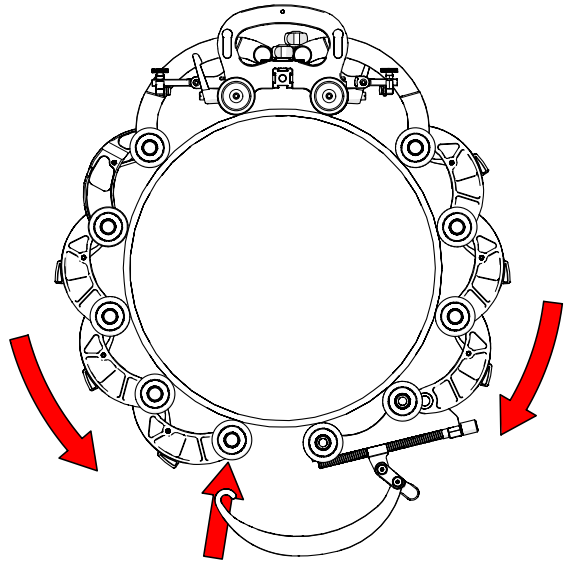

Fig. 108 - Hook QuickLink Buckle to QuickLink

7. The QuickLink Buckle adjustment knob (Fig. 109-1) may have to be loosened to allow the arm to reach the QuickLink.

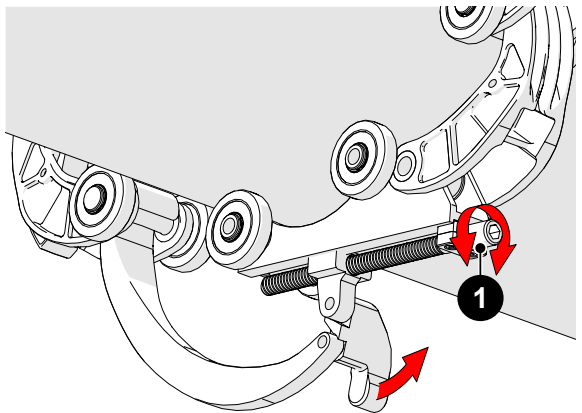

Fig. 109 - Adjust pressure of QuickLink Buckle

8. Rotate the knob until the QuickLink Buckle's lever can be pushed down, locking the QuickLink Buckle in place (Fig. 110). The tightness of the **ROTIX** on the pipe can be adjusted using the QuickLink Buckle adjustment knob (Fig. 109-1).

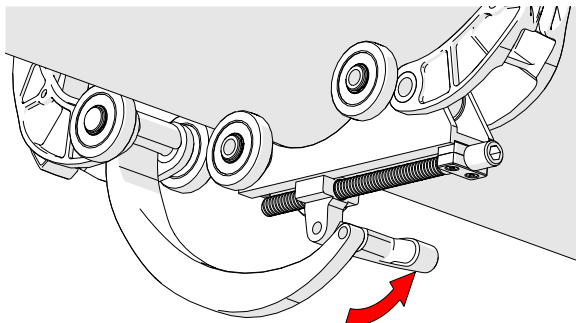

Fig. 110 - Press down to lock

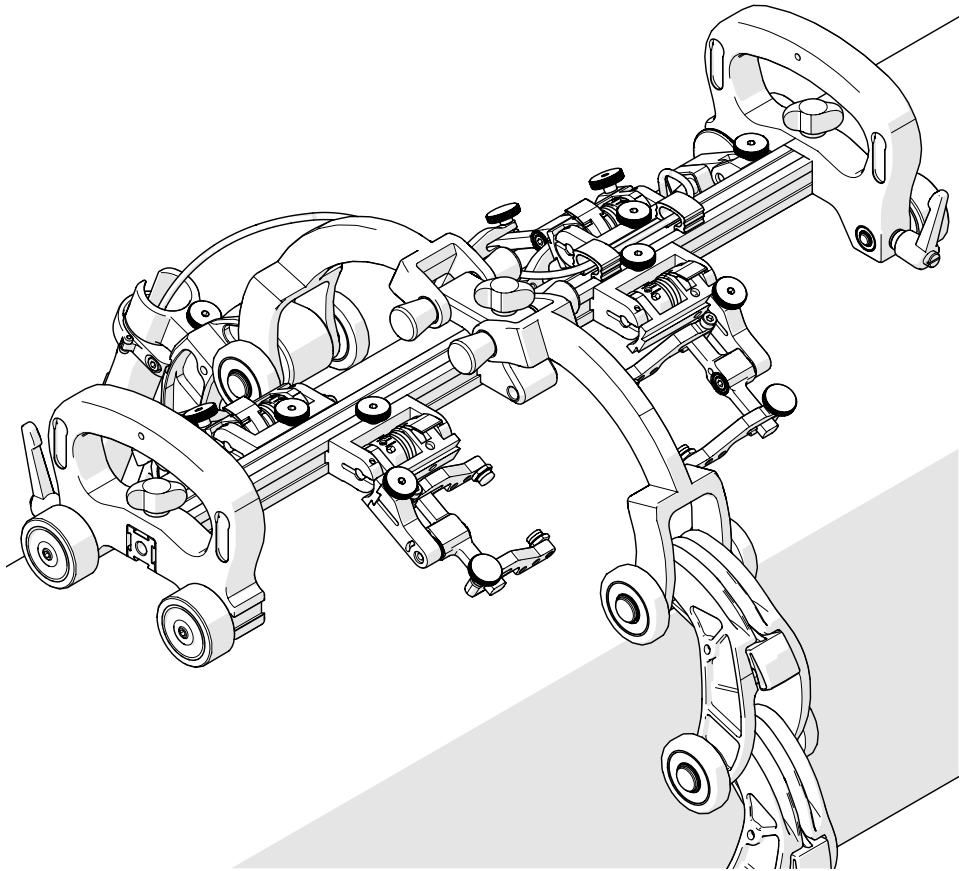

Fig. 111 - Configured four probe configuration

9. Route all cabling and hoses (*Only encoder cable shown*) to the cable management (*see Cable Management System on page 33*).
10. Lower probe holders to the scan surface (*see Slip Joint Probe Holder on page 27*).
11. Release the brakes on the wheel blocks with handle to commence scanning (*see Wheel Block with Handle on page 19*).

## MAINTENANCE

General cleaning of components is important to keep your system working well. All components that have no wiring or cables are completely waterproof. Components can be washed with warm water, dish soap and a medium bristle brush.

Before using the scanner, ensure all connectors are free of water and moisture.

**NOTE:** *All components with wiring, cables or electrical connections are splashproof. However, these components are NOT submersible.*

**NOTE:** *Never use strong solvents or abrasive materials to clean your scanner components.*

# TROUBLESHOOTING

Problem	Possible Cause	Solution
The QuickLink chain is too loose/tight	Incorrect number of QuickLinks for proper scanner configuration.	Refer to the <b>ROTIX</b> setup chart ( <i>see Weld Frame Setup Chart on page 58</i> ) for the required number of links for the diameter of pipe/tube that is to be scanned. Ensure the correct outer diameter measurement of the pipe/tube. Reset the scanner with the correct number of QuickLinks.
	The QuickLink Buckle is incorrectly setup.	Adjust the tightness of the QuickLink Buckle ( <i>see Setup of ROTIX on a Scanning Surface on page 40</i> )
Insufficient probe contact.	The scanner is not set correctly.	Reconfigure the scanner as per instructions ( <i>see Setup of ROTIX on a Scanning Surface on page 40</i> )
	The probe holder needs to be set up correctly.	Reconfigure the probe holder(s) as per instructions ( <i>see Probe Holder Setup on page 27</i> ).

## 8.1. Technical Support

For technical support contact, Jireh Industries (*see "Jireh Industries Ltd." on page 1*).

## SERVICE AND REPAIR



**WARNING! DO NOT DISASSEMBLE.** No user-serviceable parts. Disassembling any of the components in this product, beyond the instructions in this user manual, could void the regulatory certifications and/or effect the safety of the product.

# SPARE PARTS

To order accessories or replacement parts for your ROTIX system.  
 (contact Jireh Industries Ltd. on page 1)

**NOTE:** These drawings are for parts order. This is not a list of kit contents.

## 10.1. Standard Kit Components

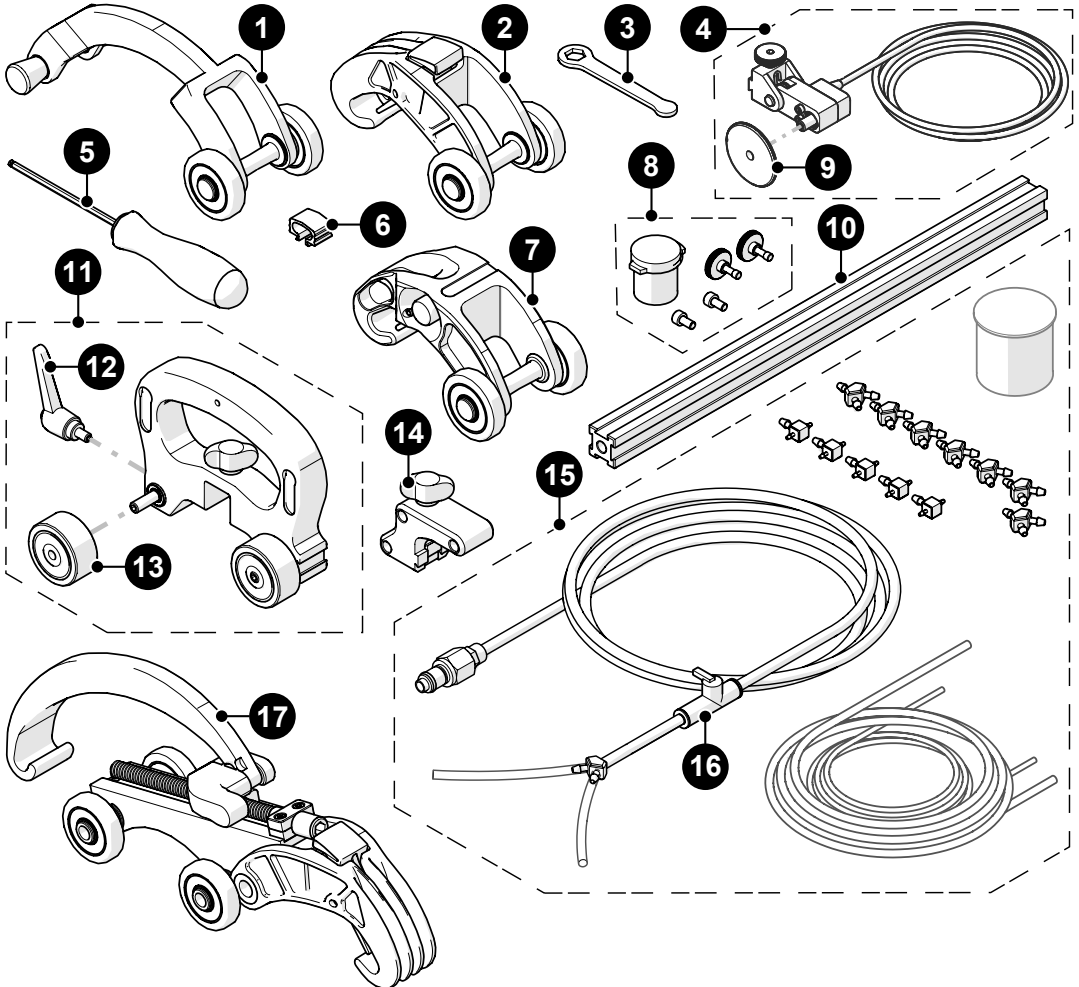

Fig. 112 - ROTIX standard parts

BOM ID	Part #	Description
1	EJS013	Standard overtop link
2	EES004	QuickLink

3	EA470	3/8 in wrench
4	BGS053-__	Spring-Loaded Encoder (see Encoder Connector Type)
5	EA414	Hex driver, 3 mm (0.118 in)
6	BG0091	Cable clip
7	EES019	Dovetail QuickLink
8	PHG014	Probe holder spare parts kit
9	BG0069	Encoder wheel, for spring-loaded encoder
10	BG0038-__	Frame bar (see Frame Bar)
11	CES070	Wheel block with handle
12	BTS018	Brake handle
13	CES012	Non-magnetic wheel
14	CES032	Double chain mount
15	CMG007	Irrigation kit, 2-4 probe
16	LA034	Irrigation Shutoff Valve
17	EES014	QuickLink buckle

## 10.2. High Temperature Kit Components

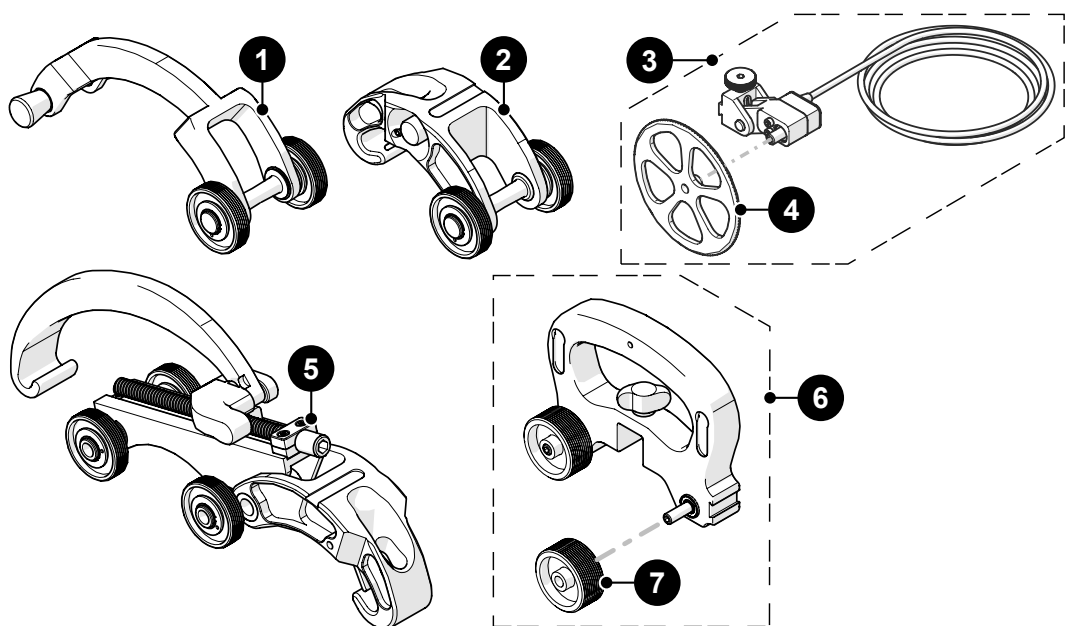

Fig. 113 - ROTIX high temperature parts

BOM ID	Part #	Description
1	CES107	High temperature standard overtop link
2	CES109	High temperature dovetail QuickLink
3	BGS071-__	High temperature spring-loaded encoder (see <i>Encoder Connector Type</i> )
4	BG0108	High temperature encoder wheel, for high temperature spring-loaded encoder
5	CES108	High temperature QuickLink buckle
6	CES071	High temperature wheel block with handle
7	CE0143	High temperature wheel

### 10.2.1. Encoder Connector Type

Connector Type	Company/Instrument	Connector Type	Company/Instrument
B	Olympus OmniScan MX Zetec Topaz	G	Sonotron Isonic 25xx
C	Olympus Focus LT Zetec Z-Scan Eddyfi Ectane 2	U	Sonatest Veo / Prisma
E	Olympus OmniScan SX/MX2/X3 M2M MANTIS/GEKKO LEMO	V	Pragma PAUT
F	TD ( <i>Technology Design</i> )	AD	Sonatest Veo / Prisma - Single Axis

**NOTE:** Additional encoder connector types are available.  
(contact Jireh Industries Ltd. on page 1)

## 10.3. Accessories

### 10.3.1. Cable Management, Dovetail Mount

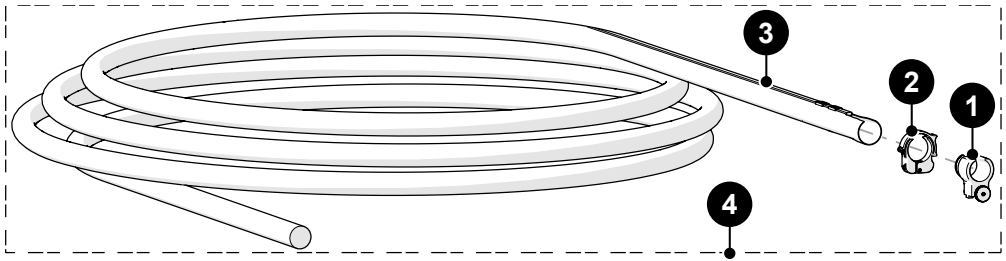

BOM ID	Part #	Description
1	CES067	Cable Management Mount, Dovetail Mount
2	CES066	Cable Management Clamp, Dovetail Mount
3	<i>See Cable Management Sleeving</i>	
4	CES044-__	Cable Management: Dovetail ( <i>see cable management sleeving</i> )

Fig. 114 - Cable management

#### 10.3.1.1 Cable Management Sleeving

Part #	Length
CX0141	4.5 m (14.7 ft)
CX0145	9.5 m (31.2 ft)

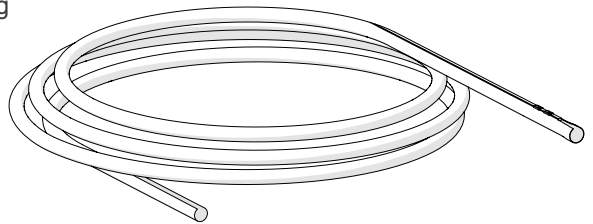
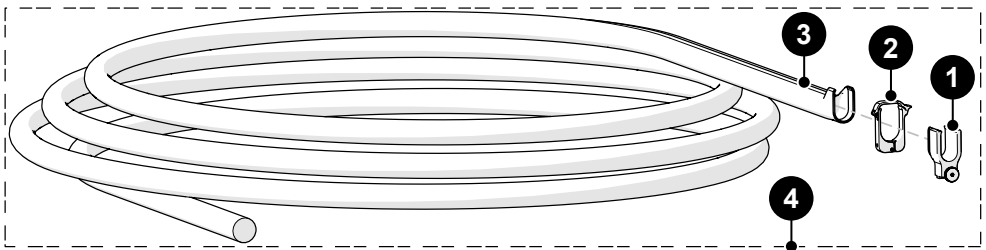

Fig. 115 - Cable management sleeving

### 10.3.2. High Temperature Cable Management, Dovetail Mount



BOM ID	Part #	Description
1	CES090	High Temperature Cable Management Mount
2	CXS114	High Temperature Cable Management Clamp
3	CX0537-04.5	High Temperature Cable Management Sleeving, 4.5 m (14.8 ft)
4	CES089-04.5	High Temperature Cable Management, 4.5 m (14.8 ft)

Fig. 116 - High temperature cable management

### 10.3.3. Preamp Bracket

BOM ID	Part #	Description
1	CES029	Preamp Bracket
2	CES029-V	Preamp Bracket with Velcro

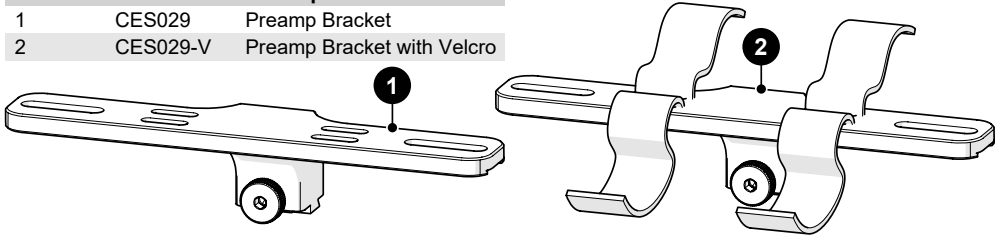

Fig. 117 - Preamp bracket

### 10.3.4. Magnetic Wheel Kit

Part #	Description
BTG014	Magnetic Wheel Kit

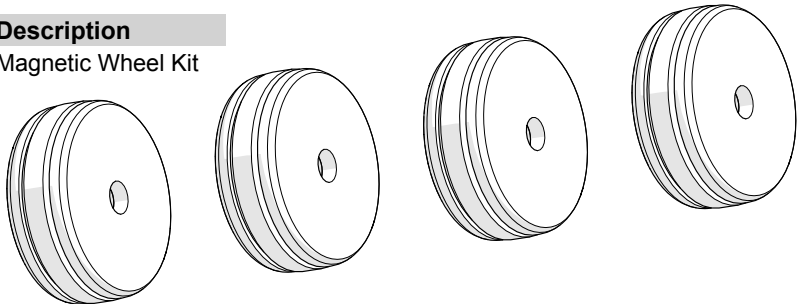
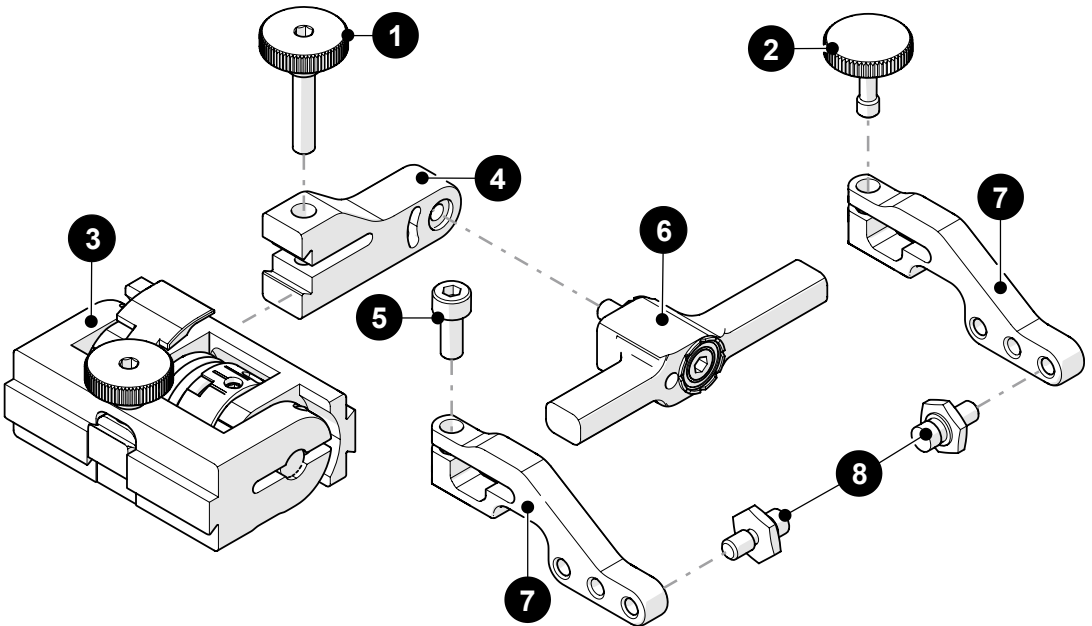

Fig. 118 - Magnetic wheel kit

## 10.4. Probe Holders

### 10.4.1. Slip Joint Probe Holder Parts



BOM ID	Part #	Description
1	PH0104	Knurled Knob, M4 x 0.7 x 18 mm, 4 mm stand off, SST
2	PH0082	Knurled Knob, M4 x 0.7 x 10 mm, 3 mm stand off, SST
3	PHS022	Slip Joint Probe Holder Subassembly
4	<i>see Swing Arm Style</i>	
5	MD050-010	SHCS, M4 x 0.7 x 10 mm, SST
6	<i>see Yoke Style</i>	
7	<i>see Arm Style</i>	
8	PH0011- <u>    </u>	Pivot Button Style ( <i>see Pivot Button Style</i> )

Fig. 119 - Slip joint probe holder parts

# 10.5. Probe Holder Components

## 10.5.1. Arm Style









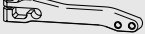

Arm Style	Part #		Arm Style	Part #	
<b>A</b> Standard, Flat	PH0090		<b>B</b> Short, Flat	PH0089	
<b>C</b> Long, Flat	PH0099		<b>D</b> Standard, Drop	PH0093	
<b>E</b> Short, Drop	PH0092		<b>F</b> Long, Drop	PH0094	
<b>G</b> Standard, Extra-Drop	PH0096		<b>H</b> Short, Extra-Drop	PH0095	
<b>I</b> Extra-Short, Flat	PH0159		<b>J</b> Extra-Short, Drop	PH0161	

Fig. 120 - Probe holder arm selection

## 10.5.2. Yoke Style

Yoke Style	Part #	Length		Yoke Style	Part #	Length	
<b>S</b> Standard	PHS052	6.3 cm (2.47 in)		<b>W</b> Wide	PHS063	7.9 cm (3.06 in)	

Fig. 121 - Probe holder yoke selection

## 10.5.3. Swing Arm Style

Swing Arm Style	Part #	Length		Swing Arm Style	Part #	Length	
Short	PH0069	4.1 cm (1.61 in)		Long	PH0100	4.6 cm (1.81 in)	

Fig. 122 - Swing arm selection

**NOTE:** Short swing arm only compatible with standard yoke style.

## 10.5.4. Pivot Button Style











Pivot Hole Size	Wedge Type		Pivot Hole Size	Wedge Type	
<b>01</b> 8.0 mm (0.315 in)	Olympus PA		<b>02</b> 5.0 mm (0.197 in)	Olympus TOFD	
<b>03</b> 2.7 mm (0.106 in)	Sonatest DAAH PA		<b>04</b> 9.5 mm (0.375 in)	-	
<b>06</b> 3.0 mm (0.118 in)	-		<b>07</b> 2.3 mm (0.09 in)	-	
<b>08</b> Conical Head	-		<b>09</b> 5 mm (0.197 in) Internal	Zetec PA/TOFD	
<b>11</b> 3 mm (0.118 in) Internal	-		<b>14</b> 4 mm (0.157 in)	-	

Fig. 123 - Pivot button selection

**NOTE:** Additional probe holder pivot button types are available. (contact Jireh Industries Ltd. on page 1)

## 10.6. Variable Components

### 10.6.1. Frame Bars











Part #	Length		Part #	Length	
BG0038-05	5 cm (1.97 in)		BG0038-10	10 cm (3.94 in)	
BG0038-15	15 cm (5.91 in)		BG0038-20	20 cm (7.87 in)	
BG0038-25	25 cm (9.84 in)		BG0038-30	30 cm (11.81 in)	
BG0038-35	35 cm (13.78 in)		BG0038-40	40 cm (15.75 in)	
BG0038-45	45 cm (17.72 in)		BG0038-50	50 cm (19.69 in)	
BG0038-55	55 cm (21.65 in)				

Fig. 124 - Frame bar selection

## 10.7. Case

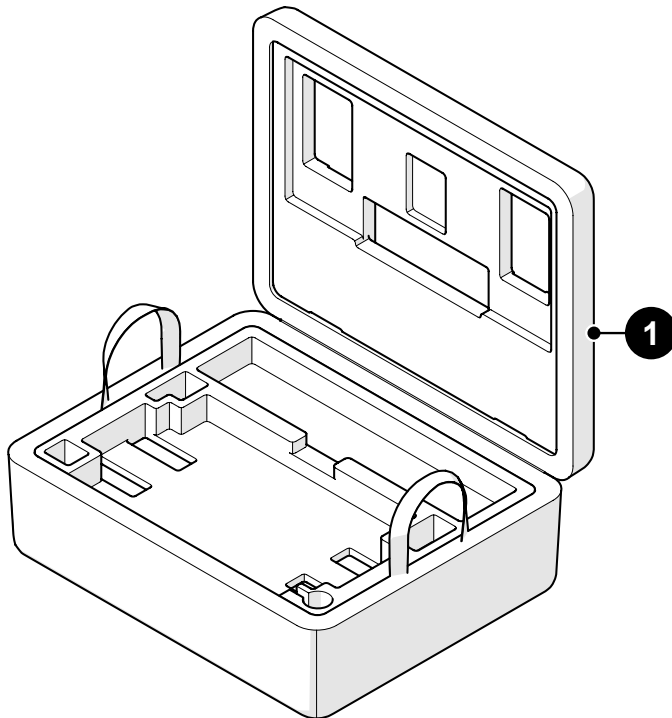

BOM ID	Part #	Description
1	CEA044	ROTIX case

Fig. 125 - ROTIX case

## DISPOSAL

### WEEE Directive

In accordance with European Directive on Waste Electrical and Electronic Equipment (*WEEE*), this symbol indicates that the product must not be disposed of as unsorted municipal waste, but should be collected separately. Refer to Jireh Industries for return and/or collection systems available in your country.



# LIMITED WARRANTY

## WARRANTY COVERAGE

Jireh Industries warranty obligations are limited to the terms set forth below: Jireh Industries Ltd. (“Jireh”) warrants this hardware product against defects in materials and workmanship for a period of THREE (3) YEARS from the original date of purchase. If a defect exists, at its option, Jireh will (1) repair the product at no charge, using new or refurbished replacement parts, (2) exchange the product with a product that is new or which has been manufactured from new or serviceable used parts and is at least functionally equivalent to the original product, or (3) refund the purchase price of the product. A replacement product/part assumes the remaining warranty of the original product or ninety (90) days from the date of replacement or repair, whichever provides longer coverage for you. When a product or part is exchanged, any replacement item becomes your property and the replaced item becomes Jireh’s property. When a refund is given, your product becomes Jireh’s property.

## OBTAINING WARRANTY SERVICE

To utilize Jireh’s warranty service you must ship the product, at your expense, to and from Jireh Industries. Before you deliver your product for warranty service you must phone Jireh and obtain an RMA number. This number will be used to process and track your product. Jireh is not responsible for any damage incurred during transit.

## EXCLUSIONS AND LIMITATIONS

This Limited Warranty applies only to hardware products manufactured by or for Jireh Industries. This warranty does not apply: (a) to damage caused by accident, abuse, misuse, misapplication, or non-Jireh products; (b) to damage caused by service (including upgrades and expansions) performed by anyone who is not a Jireh Authorized Service Provider; (c) to a product or a part that has been modified without the written permission of Jireh.

**Jireh Industries Ltd.**  
53158 Range Road 224  
Ardrossan AB T8E 2K4  
Canada  
780-922-4534  
jireh.com

All brands are trademarks or registered trademarks of their respective owners and third-party entities.

Changes or modifications to this unit or accessories not expressly approved by the party responsible for compliance could void the user's authority to operate the equipment.

All specifications are subject to change without notice.

© 2023 - 2025 JIREH Industries Ltd.

# APPENDIX

## 13.1. Weld Frame Setup Chart

PIPE OD RANGE					
MIN (in)	MAX (in)	MIN (mm)	MAX (mm)	QUICKLINKS EES004	DOVETAIL QUICKLINK EES019
4.9	6.0	124	152	0	0
6.0	7.1	152	180	0	
7.1	8.2	180	208	1	
8.1	9.3	206	236	2	
9.2	10.4	234	264	3	
10.3	11.5	262	292	4	
11.4	12.6	290	320	5	
12.5	13.7	318	348	6	
13.6	14.8	345	376	7	
14.7	15.9	373	404	8	
15.7	17.0	399	432	9	
16.8	18.1	427	460	10	
17.9	19.2	455	488	11	
19.0	20.3	483	516	12	
20.1	21.4	511	544	13	
21.2	22.4	538	569	14	
22.2	23.5	564	597	15	1
23.3	24.6	592	625	16	
24.4	25.7	620	653	17	
25.5	26.8	648	681	18	
26.6	27.9	676	709	19	
27.6	29.0	701	737	20	
28.7	30.0	729	762	21	
29.8	31.1	757	790	22	
30.9	32.2	785	818	23	
32.0	33.3	813	846	24	
33.0	34.4	838	874	25	
34.1	35.4	866	899	26	
35.2	36.5	894	927	27	
36.3	37.6	922	955	28	
37.3	38.7	947	983	29	
38.4	39.7	975	1008	30	

CE0208 Rev 01



Jireh Industries Ltd.  
53158 Range Road 224  
Ardrossan, Alberta  
Canada  
T8E 2K4

780-922-4534

[jireh.com](http://jireh.com)