



■ ROTIX

CE0189 Rev 00.2
Manual Chain Scanner

■ JIREH

SAFETY WARNINGS / PRECAUTIONS

KEEP THIS MANUAL – DO NOT LOSE

THIS MANUAL IS PART OF THE **ROTIX** AND MUST BE RETAINED FOR THE LIFE OF THE PRODUCT. PASS ON TO SUBSEQUENT OWNERS.

Ensure any amendments are incorporated with this document.



CAUTION! The **ROTIX** is designed for a specific use. Using the **ROTIX** outside of its intended use could cause damage to the product. Read and understand this manual before using.



WARNING! MAGNETIC MATERIAL. The wheels of this device produce a magnetic field which may cause failure or permanent damage to items such as watches, memory devices, CRT monitors, medical devices or other electronics.



People with pacemakers or ICD's must stay at least 25 cm (10 in) away at all times.



WARNING! DO NOT DISASSEMBLE. No user-serviceable parts. Disassembling any of the components in this product, beyond the instructions in this user manual, could void the regulatory certifications and/ or effect the safety of the product.



The **WEEE** symbol indicates that the product must not be disposed of as unsorted municipal waste, but should be collected separately.

(see *Disposal* on page 74)

TABLE OF CONTENTS

1	Identification	1
	1.1. Product Brand	1
	1.2. Manufacturer	1
2	Product Specifications	2
	2.1. Base ROTIX Specifications	2
	2.1.1. Intended Use	2
	2.1.2. Dimensions and Weight	2
	2.1.3. Environmental Sealing.....	3
	2.1.4. Performance Specifications	3
3	Definitions	4
	3.1. Definition of Symbols	4
	3.2. Definitions of Terms	4
4	System Components	5
	4.1. Base System Components	5
	4.1.1. Cart Body	5
	4.1.2. Slip Joint Probe Holder	5
	4.1.3. Frame Bar	5
	4.1.4. QuickLink Components	6
	4.1.5. Stabilizer Wheel	7
	4.1.6. J100 Encoder Cable	7
	4.1.7. Cable Management, Dovetail Mount	8
	4.1.8. Irrigation Kit	8
	4.1.9. Tools	8
	4.1.10. Case	8
	4.2. Compatible Components	9

4.2.1. Frame Bar	9
4.2.2. Vertical Probe Holder	9
4.2.3. Probe Positioning System (PPS)	9
4.2.4. PPS Encoder	10
4.2.5. Slider Probe Positioning System (Slider PPS)	10
4.2.6. Slider PPS Encoder	10
4.2.7. Crank Handle	11
4.2.8. Encoder Adapter	11
4.2.9. Preamp Bracket	11
4.2.10. Reduced Width Scanning Kit	12
4.3. Tools	12
4.3.1. Included tools	12
4.3.2. Optional tools	12

5

Preparation for Use 13

5.1. Configurations.....	13
5.1.1. One Probe, Single Axis Encoding	13
5.1.2. Two Probe, 1 Axis Encoding	13
5.1.3. Four Probe, Two-Axis Encoding	14
5.1.4. Single Probe, Two-Axis Encoding with Single PPS	14
5.1.5. Two Probe, Two-Axis Encoding with PPS	15
5.1.6. Four Probe, Two-Axis Encoding with PPS	15
5.1.7. Single Probe, Two-Axis Encoding with Slider PPS	16
5.1.8. Two Probe, Two-Axis Encoding with Slider PPS	16
5.2. Cart Setup And Adjustment	17
5.2.1. Cart Handle	17
5.2.2. Brake Handle	17
5.2.3. Wheel Removal/Installation	18
5.2.4. Encoder Cable Connector	18
5.2.5. Auxiliary Connector	19
5.2.6. Pivot Nose	19
5.2.7. Cable Management	20
5.2.8. Anchor Point	21
5.2.9. QuickLink Tail	21
5.2.10. QuickLink Mounting Bracket	22
5.3. Connecting QuickLinks & Dovetail Links	22
5.3.1. Connecting QuickLinks	22
5.3.2. Disconnecting QuickLinks	23
5.3.3. Disconnecting the Dovetail QuickLink	23
5.4. Stabilizer Wheel	24
5.4.1. Installing a stabilizer wheel	24

5.4.2. Ratchet Lever	25
5.5. Probe Positioning System (PPS)	26
5.5.1. Installing a Probe Positioning System	26
5.5.2. Four Probe Setup	27
5.5.3. Index Encoding	28
5.6. Slip Joint Probe Holder	29
5.6.1. Probe Holder Setup	29
5.6.2. Probe Holder Adjustment	31
5.6.3. Probe Holder Force Adjustment	31
5.6.4. Slip Joint Probe Holder Left/Right Conversion	33
5.6.5. Pivot Buttons	34
5.7. Cable Management System	35
5.7.1. Cable Management Dovetail Mount	35
5.7.2. Cable Management Setup	36
5.7.3. Clamp Setup	37
5.8. Reduced Width Scanning Kit	37
5.9. Vertical Probe Holder	38
5.9.1. Probe Holder Setup.....	38
5.9.2. Probe Holder Vertical Adjustment	39
5.9.3. Probe Holder Transverse Adjustment	40
5.9.4. Probe Holder Longitudinal Adjustment	41
5.9.5. Probe Holder Left/Right Conversion	42
5.10. Magnetic Wheel Kit	44
5.11. Single PPS	44
5.12. Slider Probe Positioning System	45
5.12.1. Slider PPS Assembly	45
5.12.2. Slider Index Encoding	47
5.13. Crank Handle	47
5.14. Preamp Bracket	48
5.14.1. Mounting Preamp Bracket	48
5.14.2. Attaching Preamp with Screws	48
5.14.3. Attaching Preamp with Velcro Straps	49

6 Operation	50
6.1. Setup of ROTIX on Scanning Surface	50
6.2. Using a Probe Positioning System (PPS)	54
6.3. Using a Slider Probe Positioning System (Slider PPS)	57

7 Maintenance	59
----------------------------	-----------

8	Troubleshooting	60
	8.1. Technical Support	60
9	Service and Repair	61
10	Spare Parts	62
	10.1. ROTIX Cart	62
	10.2. Kit Components	64
	10.2.1. Encoder Connector Type	65
	10.2.2. Stabilizer Wheel	66
	10.3. Probe Positioning	67
	10.3.1. Probe Positioning System (PPS)	67
	10.3.2. Slider Probe Positioning System (Slider PPS)	68
	10.3.3. Slider PPS Encoded Leadscrew	68
	10.4. Probe Holders	69
	10.4.1. Slip Joint Probe Holder Parts	69
	10.4.2. Vertical Probe Holder Parts	70
	10.5. Probe Holder Components	71
	10.5.1. Arm Style	71
	10.5.2. Yoke Style	71
	10.5.3. Swing Arm Style	71
	10.5.4. Pivot Button Style	71
	10.6. Variable Components	72
	10.6.1. Frame Bars	72
	10.7. Accessories	72
	10.7.1. Cable Management	72
	10.7.2. Preamp Bracket	73
	10.7.3. Magnetic Wheel Kit	73
11	Disposal	74
12	Limited Warranty	75
13	Appendix	77
	13.1. QuickLink Configuration Chart	77

IDENTIFICATION

1.1. Product Brand

This user manual describes the proper safety precautions, setup and use of the **ROTIX** scanner.

1.2. Manufacturer

Distributor:

Manufacturer:

Jireh Industries Ltd.
53158 Range Road 224
Ardrossan, Alberta, Canada
T8E 2K4
780.922.4534
jireh.com

PRODUCT SPECIFICATIONS

2.1. Base ROTIX Specifications

This section outlines the product specifications of the Base **ROTIX** System.

2.1.1. Intended Use

The **ROTIX** is a manually operated dual axis encoded scanner.

2.1.1.1 Operating Limits

Category	Parameter	Specification
Inspection Surface	Minimum OD, external circumferential pipe/tube range	7.62 cm (3 in)
	Maximum OD, external circumferential pipe/tube range	96.5 cm (38 in)

2.1.1.2 Operating Environment

The **ROTIX** scanner is designed for use in an industrial environment that is between -20°C and 50°C (-4°F and 122°F).

2.1.2. Dimensions and Weight

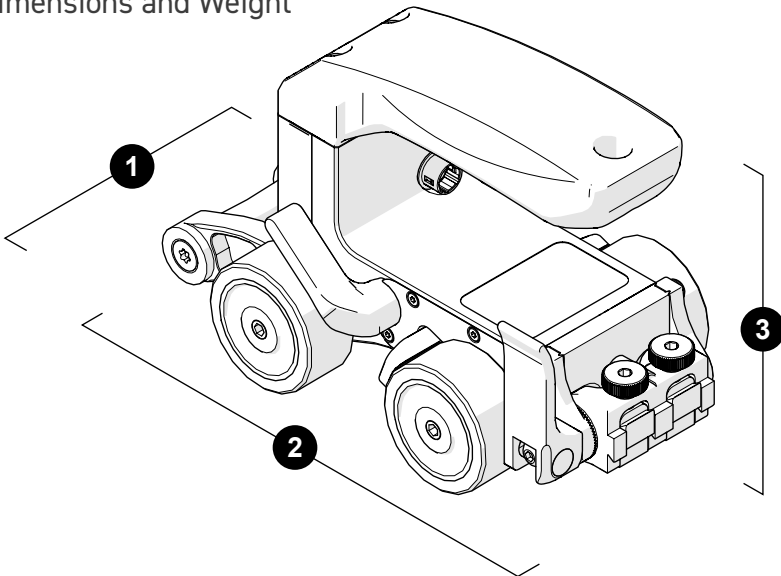

Fig. 1 - Cart dimensions

1: Cart width (Fig. 1-1)	8.1 cm	(3.2 in)
2: Cart depth (Fig. 1-2)	15.3 cm	(6 in)
3: Cart height (Fig. 1-3)	9.8 cm	(3.9 in)
Cart weight	0.67 kg	(1.48 lb)

2.1.3. Environmental Sealing

Watertight (*submersible*) (contact Jireh Industries Ltd. on page 1 for details).

2.1.4. Performance Specifications

Category	Specification
X-Axis encoder resolution	66.0 counts/mm (1676.3 counts/inch)
Y-Axis encoder resolution	40.3 counts/mm (1023.9 counts/inch)
Y-Axis encoder resolution (<i>slider PPS</i>)	161.3 counts/mm (4096.0 counts/inch)

DEFINITIONS

3.1. Definition of Symbols



Instructions to 'look here' or to 'see this part.'

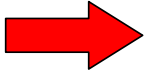

Denotes movement. Instructing the user to carry out an action in a specified direction.



Indicates alignment axis, can also indicate insertion or movement of parts.



Alerts user that the view has changed to a reverse angle.

3.2. Definitions of Terms

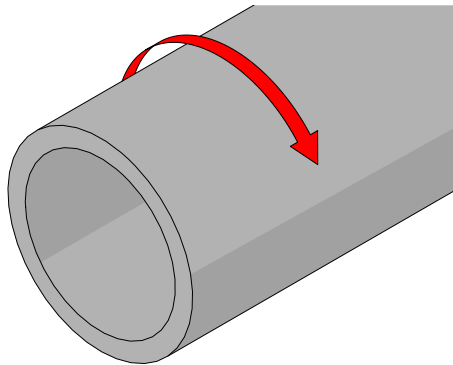

Fig. 2 - Circumferential scanning

Circumferential

Direction of scan travel is around the circumference of the pipe/tube (Fig. 2).

SYSTEM COMPONENTS

4.1. Base System Components

4.1.1. Cart Body CEA034

The cart body houses the positional encoder and provides a pivot nose for mounting frame bars and probe holders. The encoder connector is located at the rear of the cart, while the auxiliary connector is found under the handle (Fig. 3).

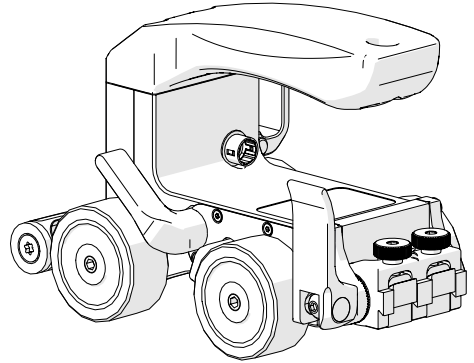

Fig. 3 - Cart body

4.1.2. Slip Joint Probe Holder PHA012-

The slip joint probe holder is generally used during limited access inspection. The low profile design requires minimal radial clearance. The slip joint probe holder is designed to carry many different types of probes and wedges. It is available with various types of yokes, arms and pivot buttons (Fig. 4).

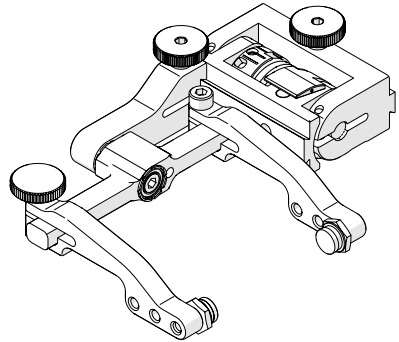

Fig. 4 - Slip joint probe holder

4.1.3. Frame Bar BG0038-

Frame bars (Fig. 5) provide a mount probe holders, probe positioning systems and other accessories.

Frame bars are available in a variety of lengths.

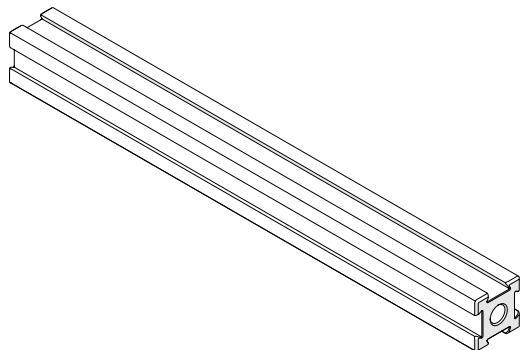

Fig. 5 - Frame bar

4.1.4. QuickLink Components

The QuickLink components fasten a **ROTIX** system circumferentially around a pipe or tube.

4.1.4.1 QuickLink EES004

QuickLinks connect to assemble the required length to mount the system on a pipe (Fig. 6).

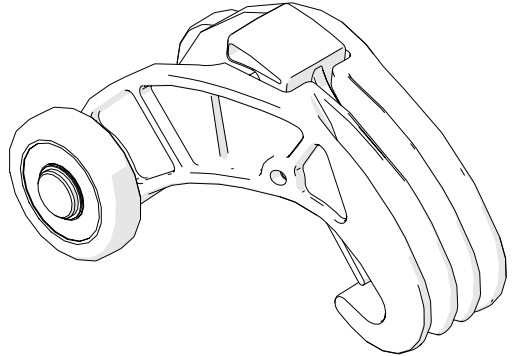

Fig. 6 - QuickLink

4.1.4.2 Dovetail QuickLink EES011

The Dovetail QuickLink connects to QuickLinks, providing a mounting point for accessories such as cable management (Fig. 7).

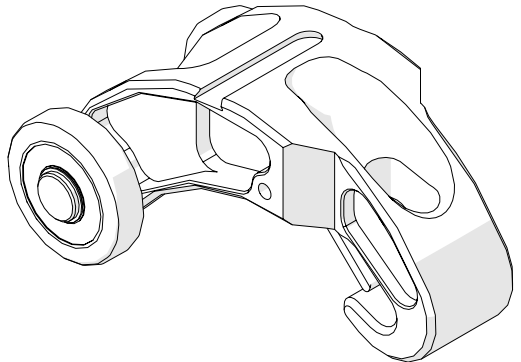

Fig. 7 - Dovetail QuickLink

4.1.4.3 QuickLink Buckle EES014

The QuickLink Buckle enables adjustment of the chain tension and provides the connection point of the QuickLinks assembly (Fig. 8).

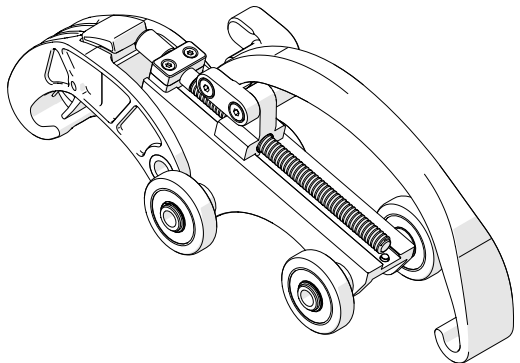

Fig. 8 - QuickLink Buckle

4.1.4.4 QuickLink Mounting Bracket CES096

The QuickLink Mounting Bracket attaches to a frame bar and provides a connection point for QuickLinks (Fig. 9).

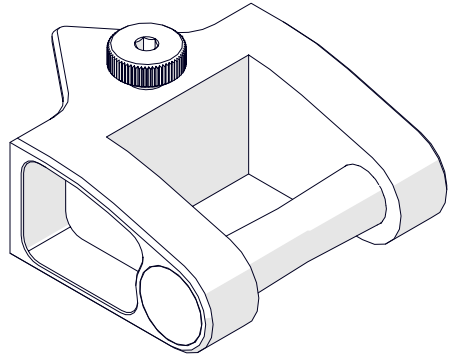

Fig. 9 - QuickLink Mounting Bracket

4.1.5. Stabilizer Wheel BTS049

A stabilizer wheel supports cantilevered **ROTIX** configurations (Fig. 10).

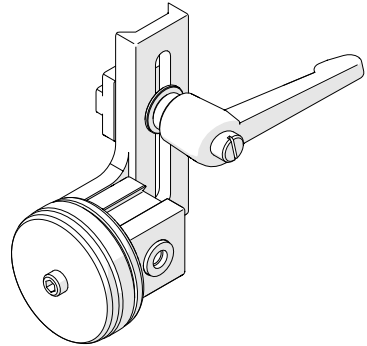

Fig. 10 - Stabilizer wheel

4.1.6. J100 Encoder Cable UMA026-

The encoder cable connects the **ROTIX** system to the user's instrument. (Fig. 11).

Various encoder cable styles are available for various instruments.

NOTE: *Inspect the cable and connectors for damage before use. When damage is evident, the cable must **NOT** be used.*

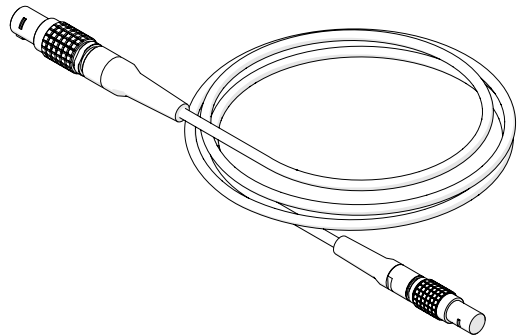

Fig. 11 - J100 encoder cable

4.1.7. Cable Management, Dovetail Mount CES044-

Cable management provides a means of protecting and organizing cables, tubes and hoses (Fig. 12).

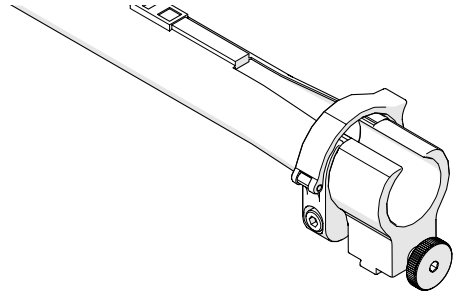

Fig. 12 - Cable management, dovetail mount

4.1.8. Irrigation Kit CMG007

The irrigation kit provides a variety of hoses, fittings, connectors, and splitters commonly used during non-destructive inspection (Fig. 13).

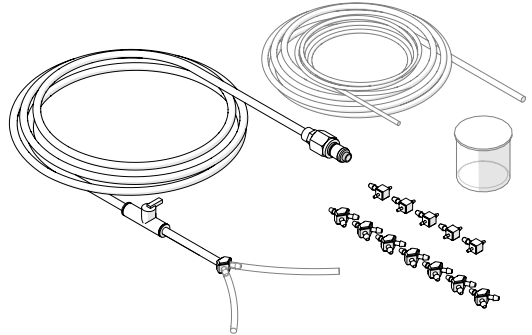

Fig. 13 - Irrigation kit

4.1.9. Tools

Several tools are included for various scanner and accessory adjustments. (see *Included tools on page 12*)

4.1.10. Case

The system is provided with a rugged carrying case.

4.2. Compatible Components

4.2.1. Frame Bar BG0038-

Frame bars (*Fig. 14*) are used to mount probe holders, probe positioning systems and other accessories.

Frame bars are available in a variety of lengths.

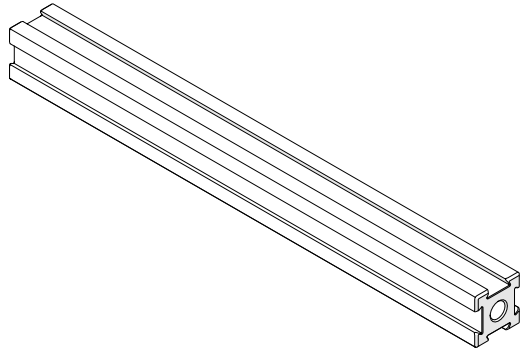

Fig. 14 - Frame bar

4.2.2. Vertical Probe Holder PHA015-

The vertical probe holder is designed to carry many different types of probes and wedges. Available with various types of yokes, arms and pivot buttons. The vertical probe holder features different adjustment options for each unique probe/wedge setup (*Fig. 15*).

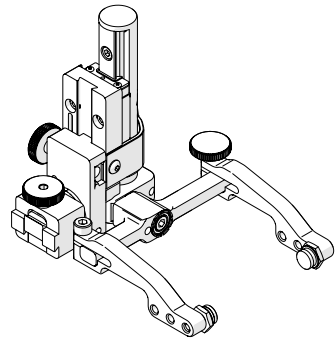

Fig. 15 - Vertical probe holder

4.2.3. Probe Positioning System (PPS) DKA001-

Control probe centre spacing and adjust probe positioning on the fly while avoiding the need to remove the scanner from the inspection surface (*Fig. 16*).

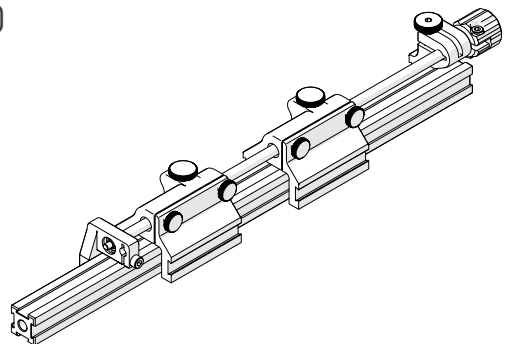

Fig. 16 - Probe Positioning System

4.2.4. PPS Encoder DKS009-

Enable two-axis encoding with
ROTIX scanners (Fig. 17).

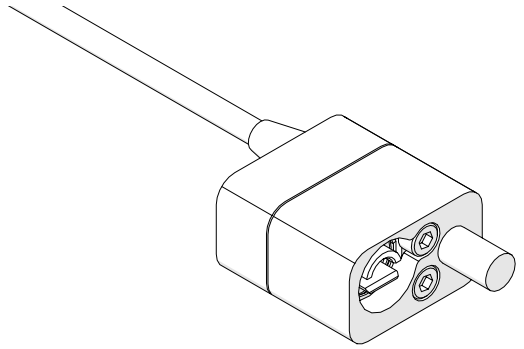

Fig. 17 - PPS encoder

4.2.5. Slider Probe Positioning System (Slider PPS) CJS016

The slider probe positioning
system sets the probe centre
spacing and allows an operator to
centre the probes around a weld
without removing the scanner
(Fig. 18).

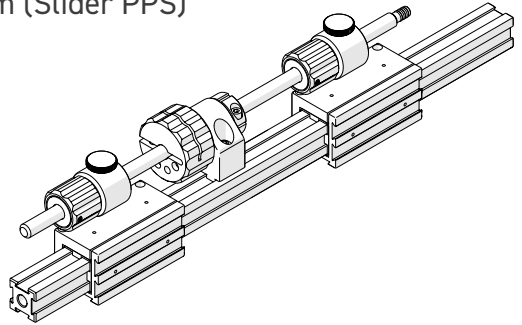

Fig. 18 - Slider probe positioning system

4.2.6. Slider PPS Encoder CJS017-

The slider PPS (probe positioning
system) encoder attaches to
the slider PPS to provide y-axis
positional encoded feedback
(Fig. 19).

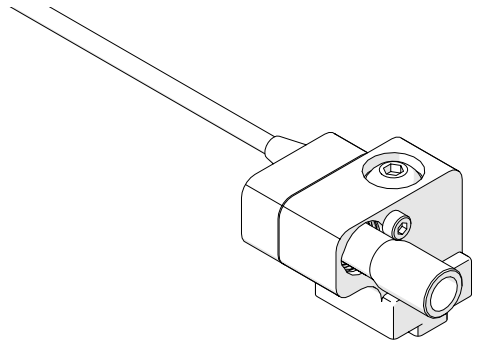

Fig. 19 - Slider PPS encoder

4.2.7. Crank Handle CJS016

The crank handle mounts to a slider probe positioning system to allow for quick and easy adjustment of probe positioning (Fig. 20).

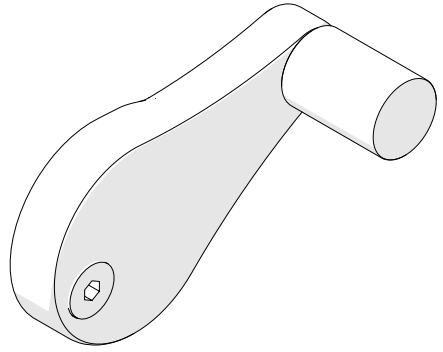

Fig. 20 - Crank handle

4.2.8. Encoder Adapter UMA010-

Adapt a scanner's existing encoder connector to a different encoder style (Fig. 21).

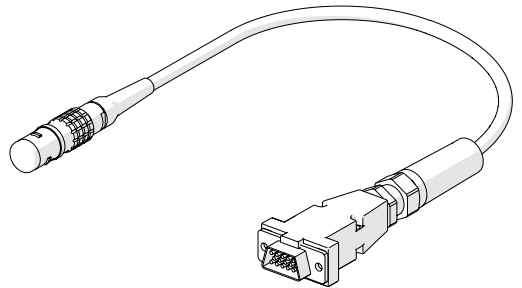

Fig. 21 - Encoder adapter

4.2.9. Preamp Bracket CES029-

A bracket that mounts to a scanner to hold various preamps (Fig. 22).

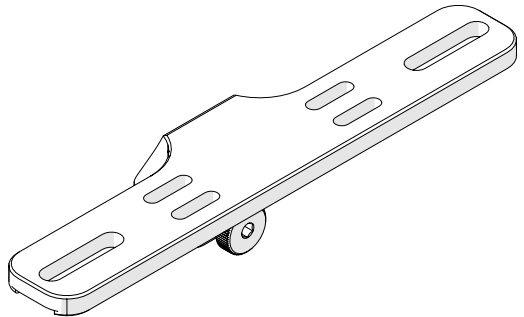

Fig. 22 - Preamp bracket

4.2.10. Reduced Width Scanning Kit CES104-

This kit reduces the scanner footprint requiring less insulation or coating to be removed from the pipe (Fig. 23).

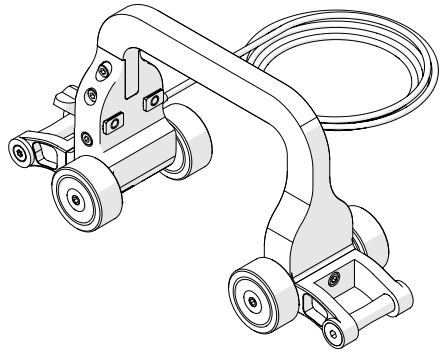

Fig. 23 - Reduced width scanning kit

4.3. Tools

4.3.1. Included tools

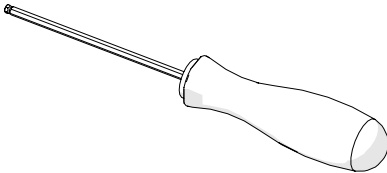

Fig. 24 - 3 mm hex driver

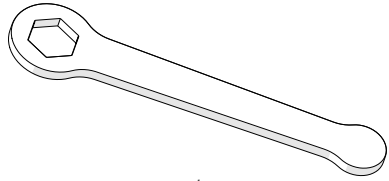

Fig. 25 - 3/8 in wrench

The 3 mm hex driver (Fig. 24) is sufficient for all typical operations and adjustments of the **ROTIX**.

The 3/8 in wrench (Fig. 25) removes and installs buttons on the probe holders.

4.3.2. Optional tools

Some specialized adjustments require tools that are not included in this kit.

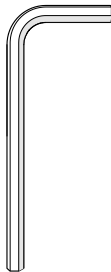

Fig. 26 - 1.5 mm hex wrench

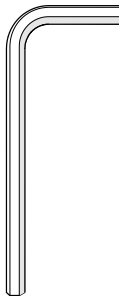

Fig. 27 - 2 mm hex wrench

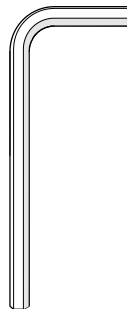

Fig. 28 - 2.5 mm hex wrench

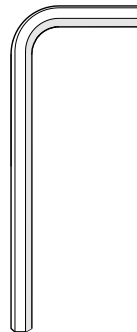

Fig. 29 - 3 mm hex wrench

PREPARATION FOR USE

5.1. Configurations

5.1.1. One Probe, Single Axis Encoding

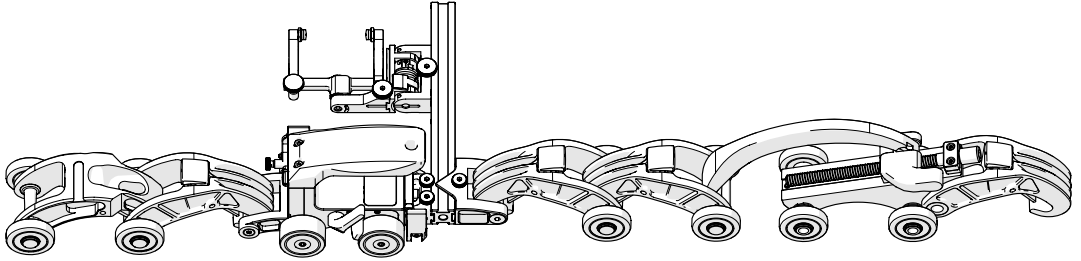

Fig. 30 - One probe, single axis encoding

5.1.2. Two Probe, 1 Axis Encoding

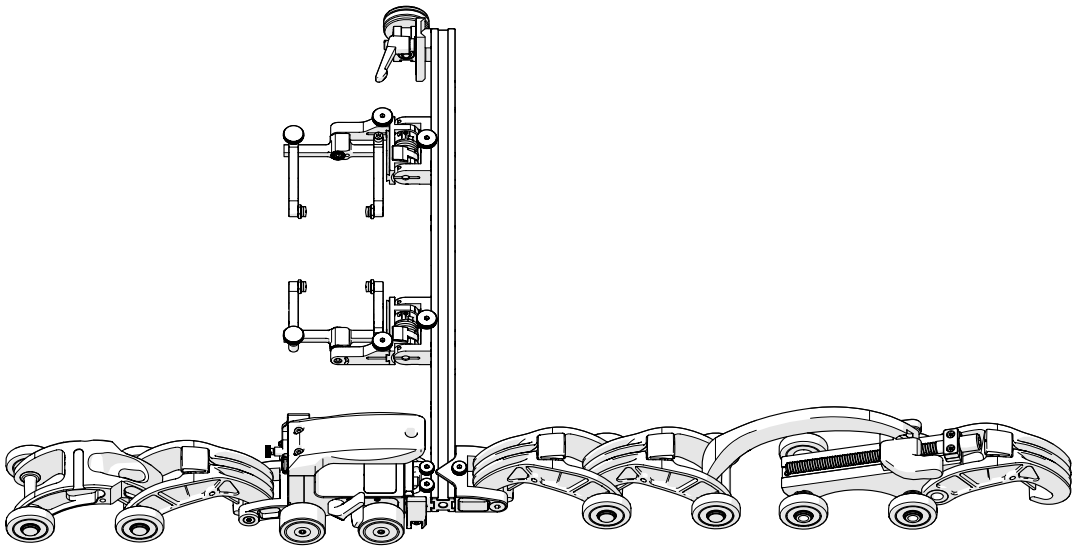

Fig. 31 - Two probe, 1 axis encoding

5.1.3. Four Probe, Two-Axis Encoding

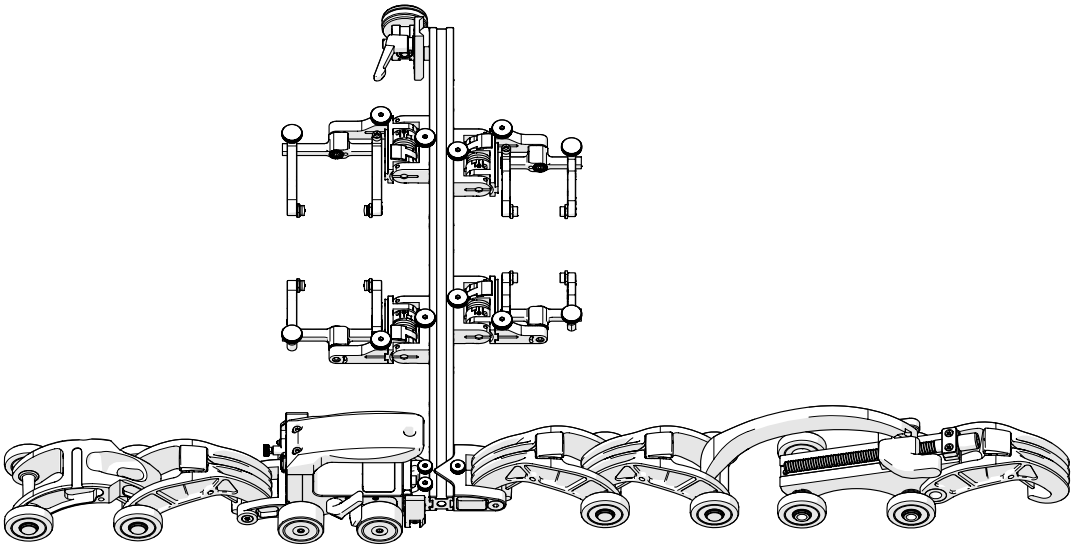

Fig. 32 - Four probe, two-axis encoding

5.1.4. Single Probe, Two-Axis Encoding with Single PPS (Probe Positioning System)

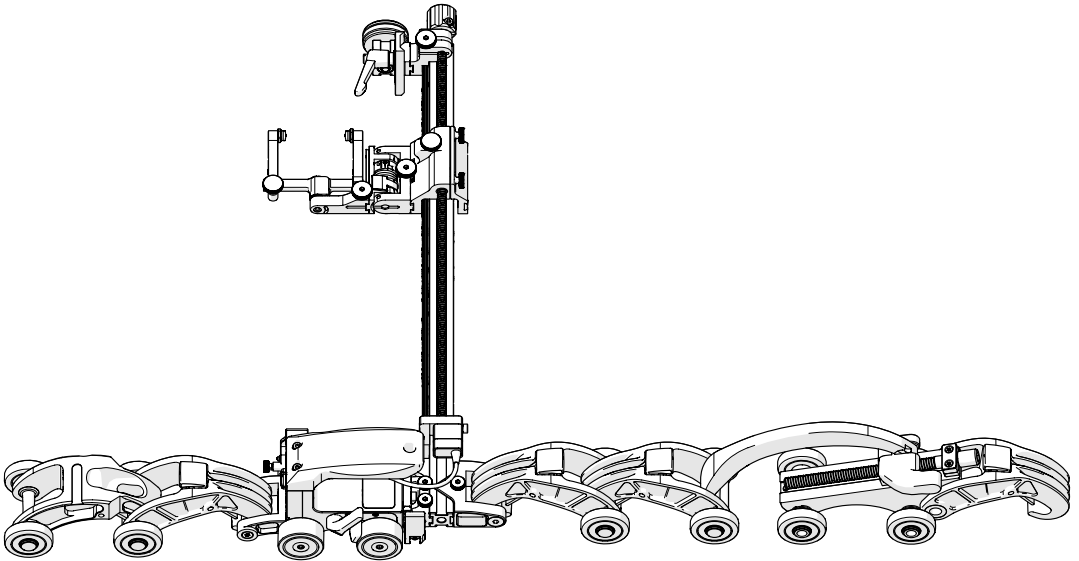

Fig. 33 - Single probe, two-axis encoding with single PPS

5.1.5. Two Probe, Two-Axis Encoding with PPS (Probe Positioning System)

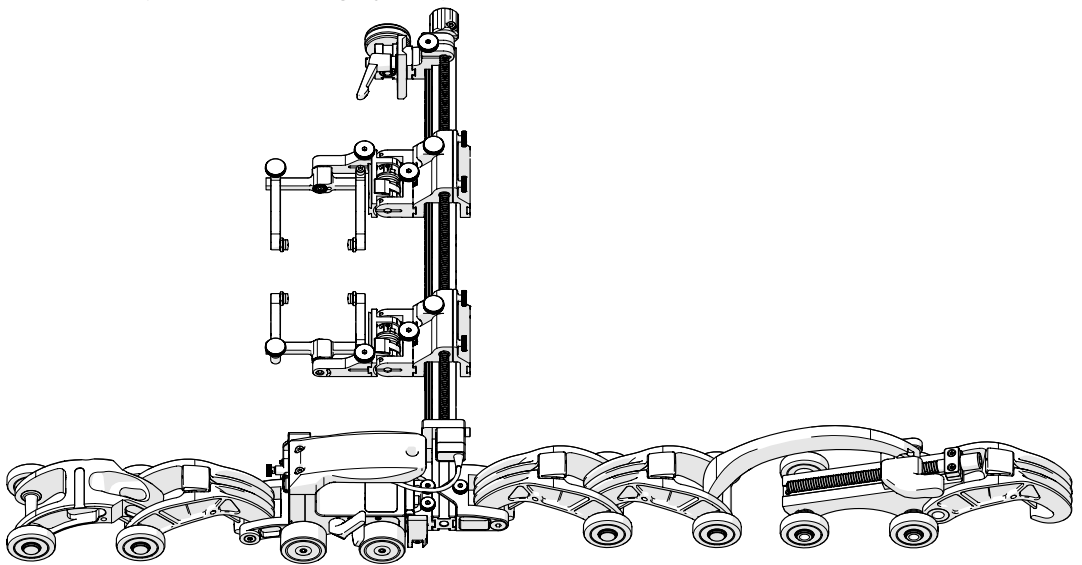

Fig. 34 - Two probe, two-axis encoding with PPS

5.1.6. Four Probe, Two-Axis Encoding with PPS (Probe Positioning System)

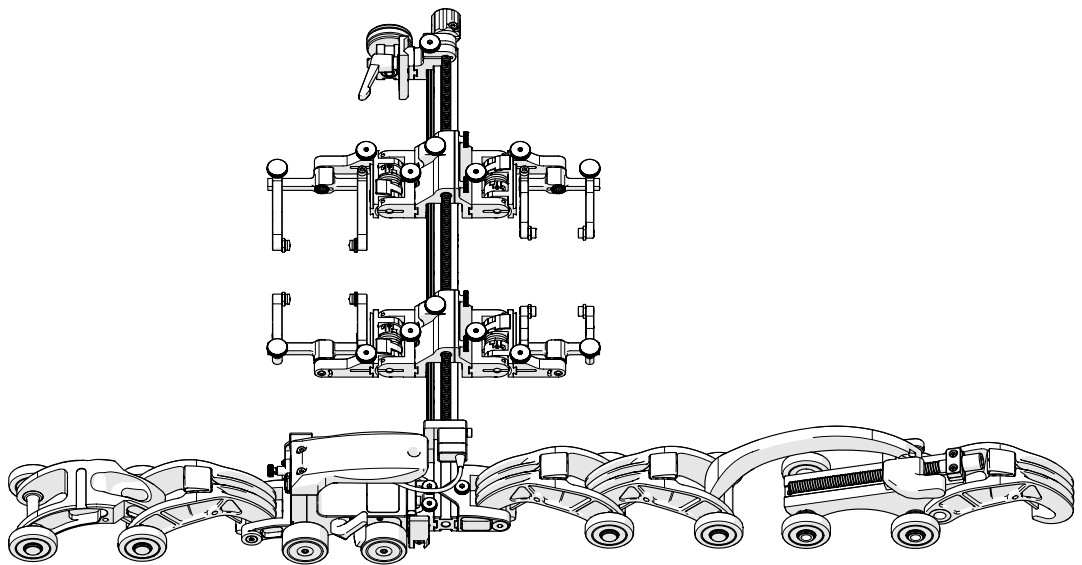

Fig. 35 - Four probe, two-axis encoding with PPS

5.1.7. Single Probe, Two-Axis Encoding with Slider PPS (Probe Positioning System)

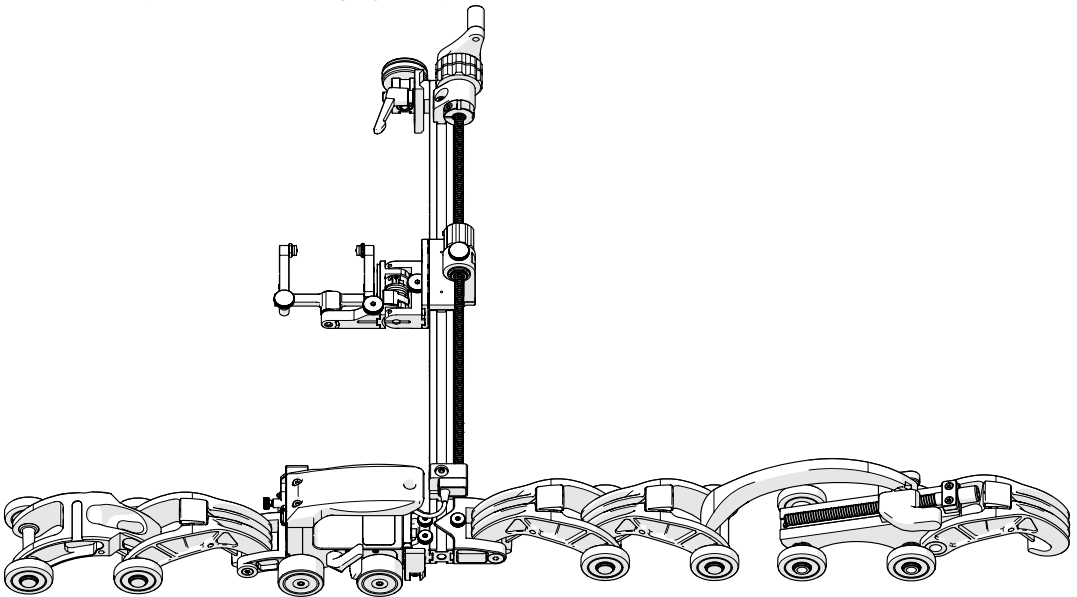

Fig. 36 - Single probe, two-axis encoding with slider PPS

5.1.8. Two Probe, Two-Axis Encoding with Slider PPS (Probe Positioning System)

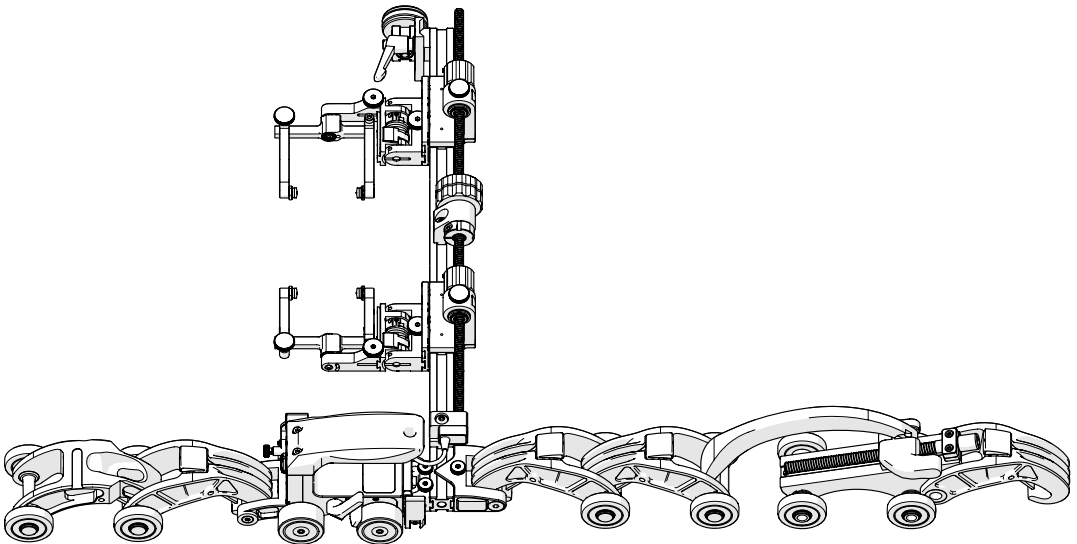

Fig. 37 - Two probe, two-axis encoding with slider PPS

5.2. Cart Setup And Adjustment

5.2.1. Cart Handle

The handle provides an ergonomic grip during use.

The cart handle may be removed using the supplied 3 mm hex driver to achieve a lower profile when required (*Fig. 38*).

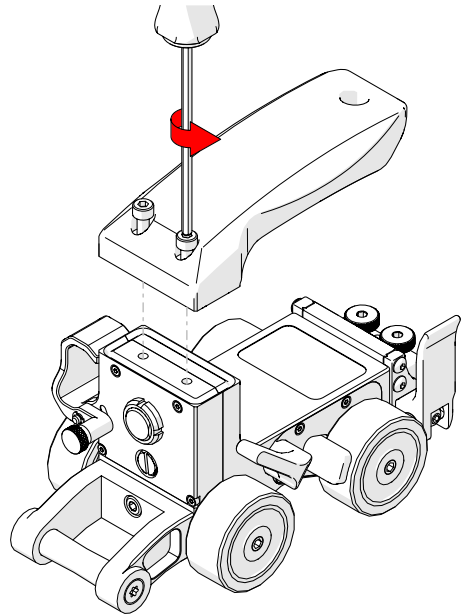

Fig. 38 - Cart handle

5.2.2. Brake Handle

Pivot the red brake lever to engage the braking system. The brake is set when the lever snaps into place (*Fig. 39*).

Reversing this action will disengage the brakes.

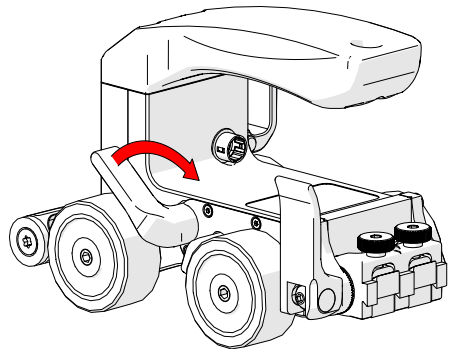

Fig. 39 - Brake handle

5.2.3. Wheel Removal/Installation

Urethane wheels provide smooth rolling and are to be used with QuickLinks.

The wheels of this system may be removed and are interchangeable.

To remove/install the wheels, insert the provided 3 mm hex driver in the shaft of the wheel you wish to remove. Thread or unthread the desired wheel with a hex driver while holding the wheel tight with the hand (Fig. 40). Reverse these steps to install wheels on the cart (Fig. 41).

TIP: Be sure all wheels are tight as this can affect encoder performance.

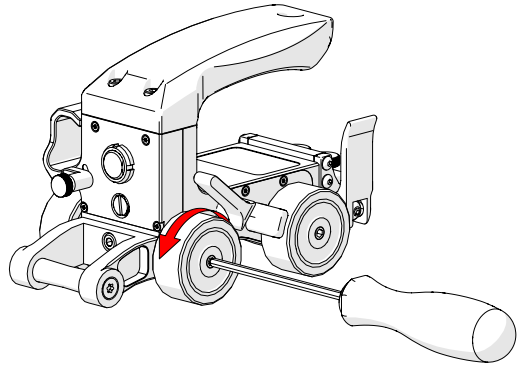

Fig. 40 - Removing wheels

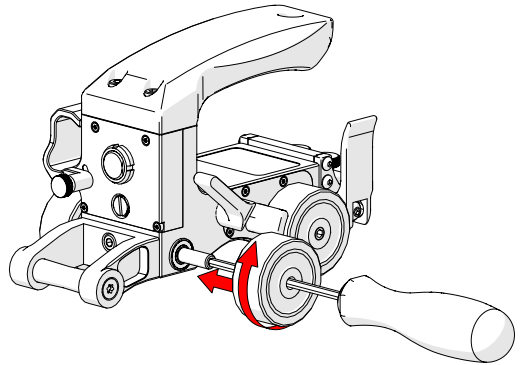

Fig. 41 - Installing wheels

5.2.4. Encoder Cable Connector

The encoder cable connector transmits multiple encoder signals to the user's instrument (Fig. 42).

NOTE: Inspect the cable and connectors for damage before use. When damage is evident, the cable must **NOT** be used.

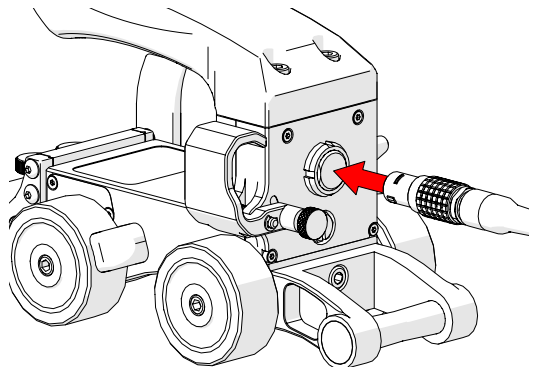

Fig. 42 - Encoder cable connector

5.2.5. Auxiliary Connector

The auxiliary connector provides a connection point for optional accessories, such as PPS encoders that provide positional feedback perpendicular to the direction of cart travel.

The auxiliary connector is found under the cart handle (Fig. 43).

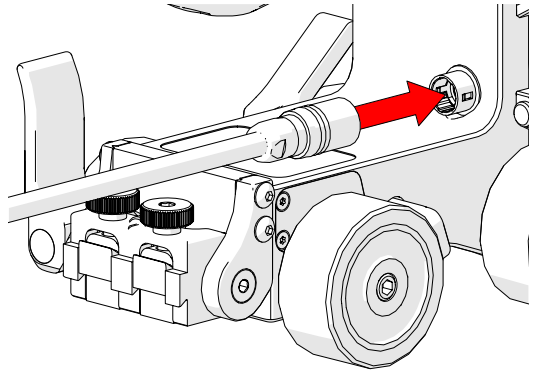

Fig. 43 - Auxiliary connector

5.2.6. Pivot Nose

The pivot nose is an attachment point for frame bars.

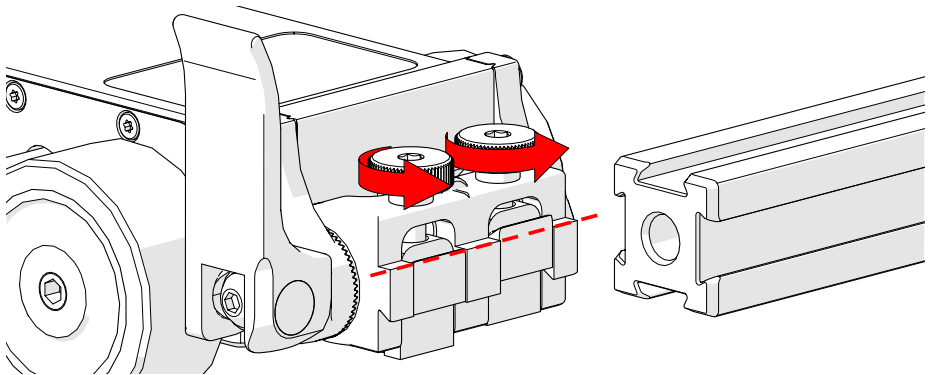

Fig. 44 - Loosen dovetail jaws and align

Attach a frame bar by loosening the dovetail jaws to align with the frame bar (Fig. 44).

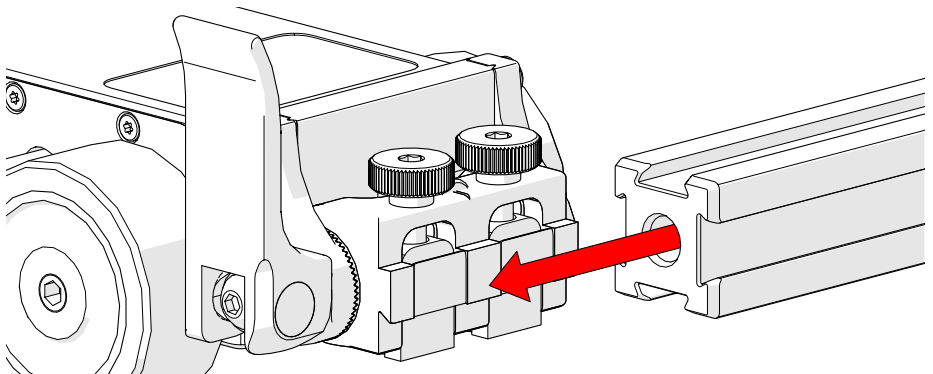

Fig. 45 - Frame bar attachment

Mount the frame bar on the dovetail jaw of the pivot mount and tighten the knobs (Fig. 45).

The angle of the frame bar should be adjusted to match the angle of the inspection surface (see instruction 6 on page 51 for additional details).

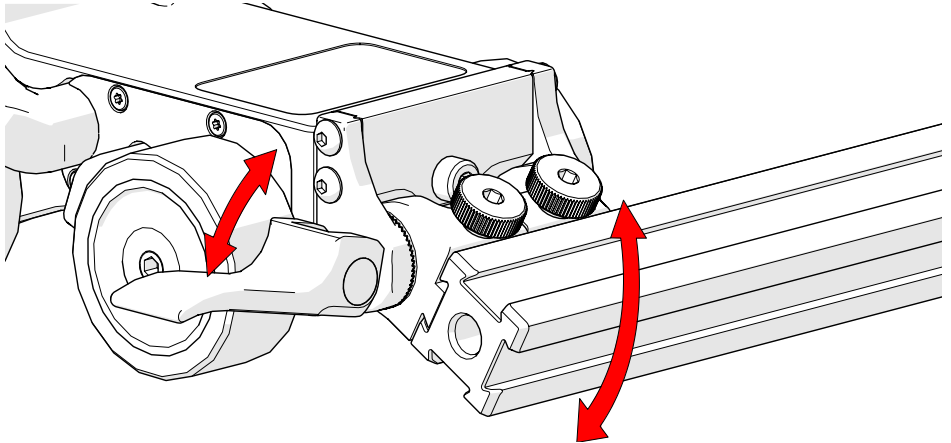

Fig. 46 - Pivot

Loosen the side-mounted lever and pivot to the desired angle, then close the side-mounted lever to lock the frame bar in position (Fig. 46).

5.2.7. Cable Management

A convenient clip is provided on the cart body to provide a method to organize and protect cables.

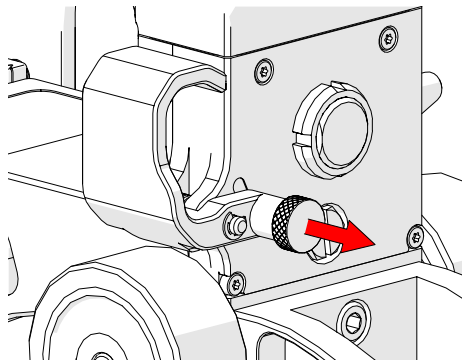

Fig. 47 - Pull latch to open clip

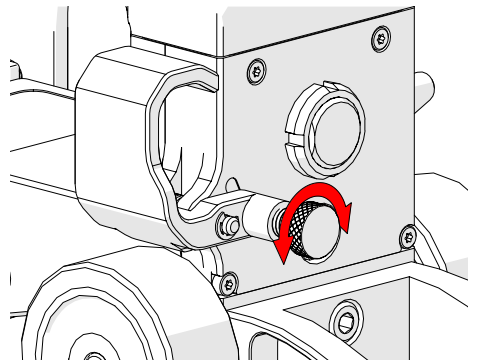

Fig. 48 - Twist latch to maintain clip movement

Pull the latch to open the cable management clip (Fig. 47).

Twisting the latch will prevent the latch from locking and, thereby, allow the cable management clip to open freely (Fig. 48).

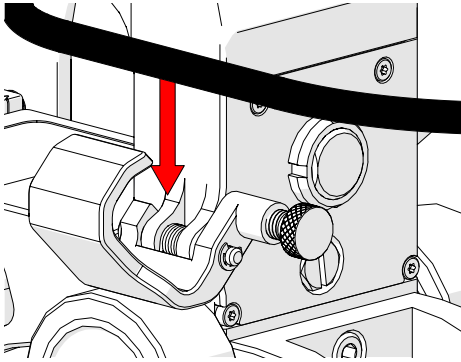

Fig. 49 - Open clip and place cables and hoses

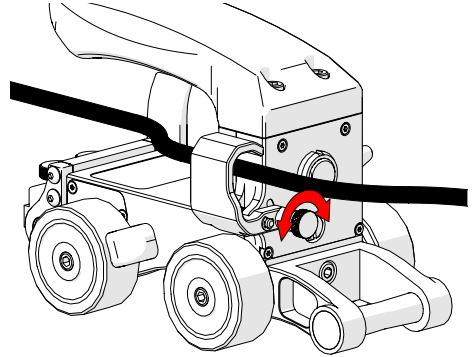

Fig. 50 - Close clip and twist latch to lock

Open the cable management clip and place cables and hoses in the clip as required (Fig. 49).

Twist to latch to lock the cable management clip closed (Fig. 50).

5.2.8. Anchor Point

The slot in the handle can be used as an anchor point for various equipment (Fig. 51).

NOTE: Carabiner not included.

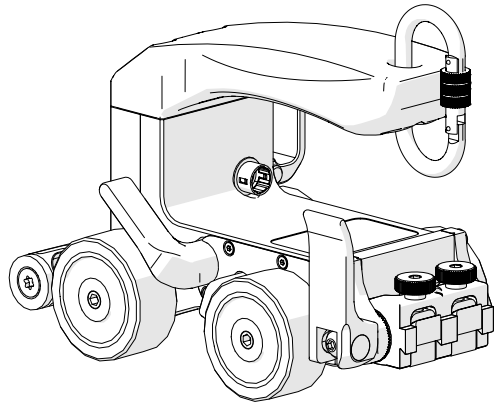

Fig. 51 - Anchor point

5.2.9. QuickLink Tail

Located at the rear of the cart body. The QuickLink Tail provides a connection point for QuickLinks (Fig. 52).

Use the supplied 3 mm hex driver to install or remove the tail.

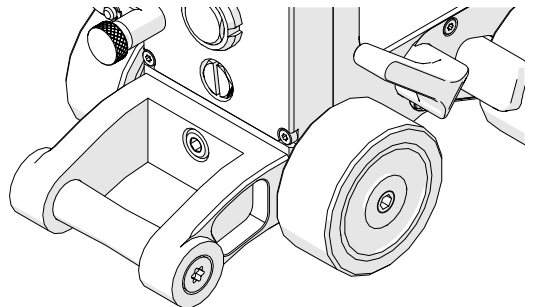

Fig. 52 - QuickLink Tail

5.2.10. QuickLink Mounting Bracket

The QuickLink Mounting Bracket provides a connection for the QuickLinks.

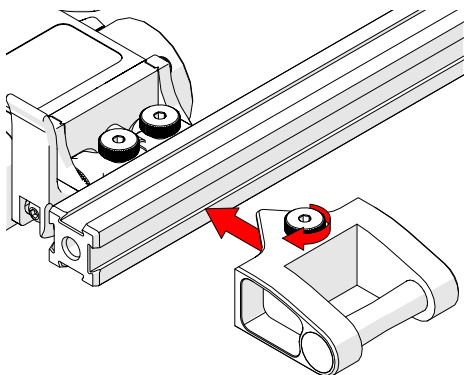

Fig. 53 - QuickLink Mounting Bracket

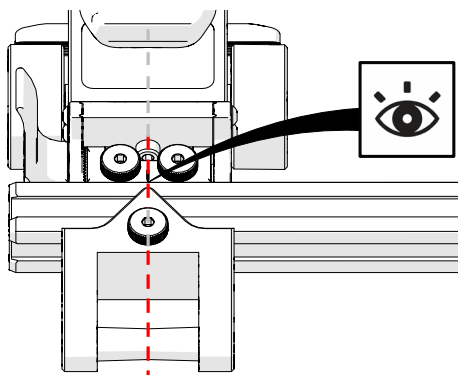

Fig. 54 - QuickLink mount alignment

Secure the QuickLink Mounting Bracket to the frame bar by tightening the knob (Fig. 53).

Centre the QuickLink Mounting Bracket to the centre point marking on the cart's pivot mount (Fig. 54).

5.3. Connecting QuickLinks & Dovetail Links

5.3.1. Connecting QuickLinks

To connect QuickLinks, see the following steps:

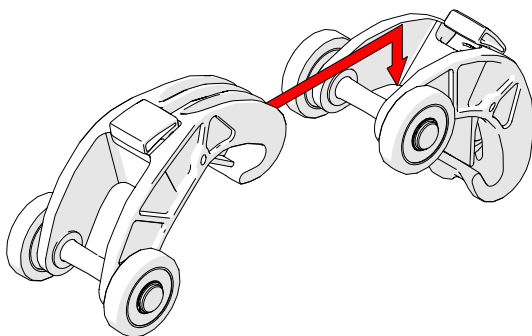

Fig. 55 - Lift the hook over the axle of the QuickLink

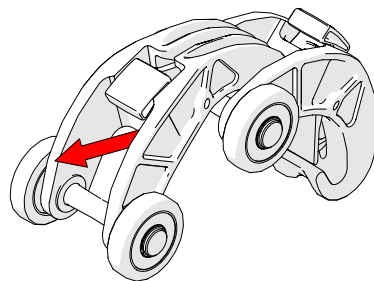

Fig. 56 - Pull the link backwards to secure catch

1. Lift the hook of the QuickLink over the axle of the QuickLink that is to be connected (Fig. 55).
2. Pull the QuickLink until you hear a click that ensures the latch has been set (Fig. 56).

5.3.2. Disconnecting QuickLinks

To disconnect QuickLinks, see the following steps:

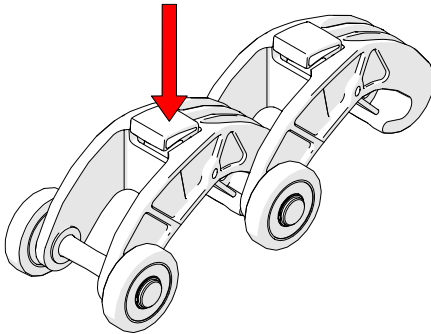

Fig. 57 - Press button

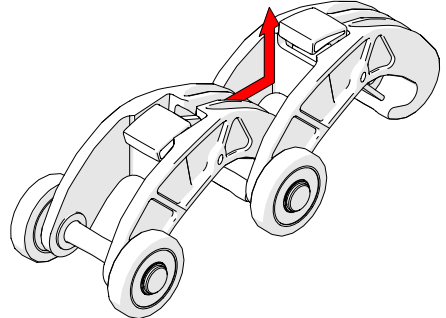

Fig. 58 - Slide QuickLink forward and lift

1. Press the button on the top of the QuickLink (Fig. 57).
2. While pressing the button, slide the QuickLink forward and up, clearing the hook of the QuickLink from the 2nd QuickLink's axle (Fig. 58).

5.3.3. Disconnecting the Dovetail QuickLink

To disconnect Dovetail QuickLinks, see the following steps:

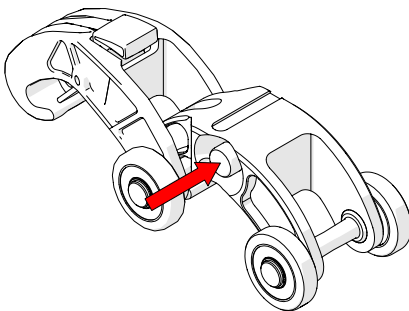

Fig. 59 - Press red button

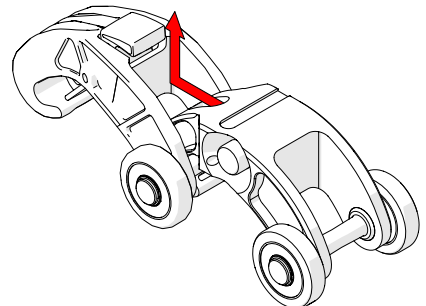

Fig. 60 - Slide Dovetail QuickLink forward and lift

1. Press the button on the side of the Dovetail QuickLink (Fig. 59).
2. While pressing the red button, slide the Dovetail QuickLink forward and up, clearing the hook of the Dovetail QuickLink from the 2nd QuickLink's axle (Fig. 60).

5.4. Stabilizer Wheel

The stabilizer wheel is used to balance the frame bar and to keep the frame bar parallel to the inspection surface.



WARNING! MAGNETIC MATERIAL. The stabilizer wheel uses a magnetic wheel. People with pacemakers or ICD's must stay at least 25 cm (10 in) away.

5.4.1. Installing a stabilizer wheel

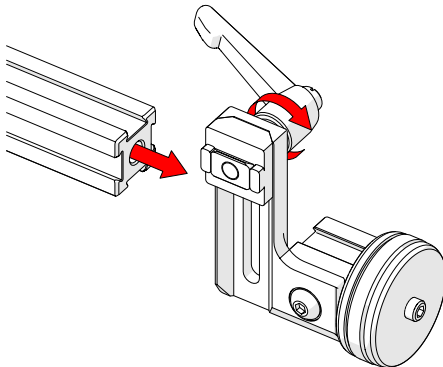

Fig. 61 - Attach frame bar

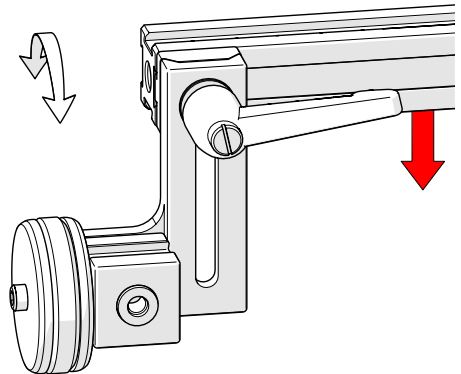

Fig. 62 - Position horizontally

To install the stabilizer wheel, ensure the dovetail nut is loose using the black ratchet lever (Fig. 61). Slide the dovetail nut onto the frame bar (Fig. 61).

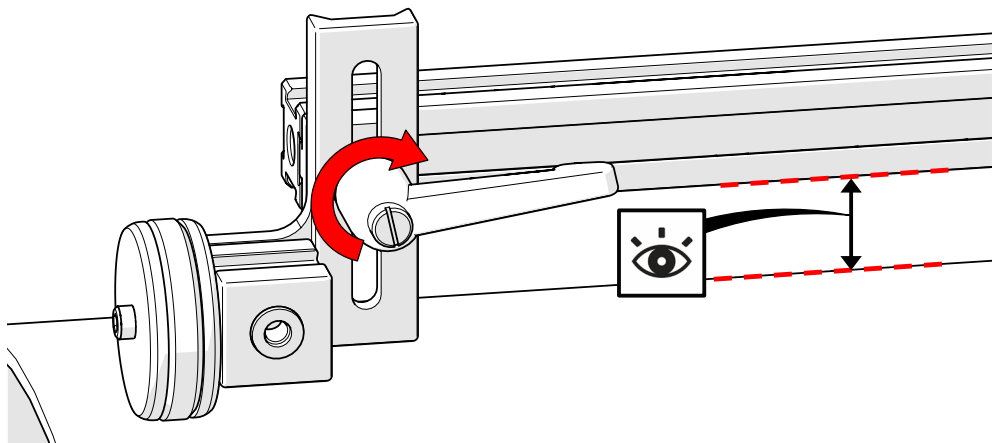

Fig. 63 - Tighten black ratchet lever when frame bar is parallel with inspection surface

Adjust the height of the stabilizer wheel's frame bar mount (Fig. 62) to ensure the frame bar is parallel with the inspection surface (Fig. 63).

Tighten using the black ratchet lever (Fig. 63).

TIP: If the ratchet lever contacts the inspection surface, the position of the ratchet lever can be adjusted by pulling the lever out and rotating it to a new position.

5.4.2. Ratchet Lever

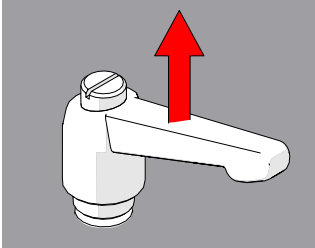

Fig. 64 - Pull ratchet handle

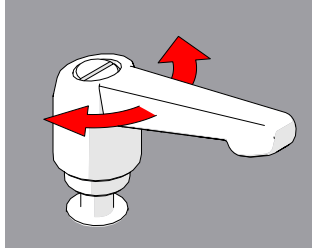

Fig. 65 - Rotate handle

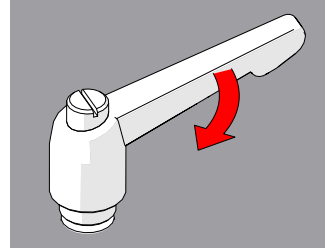

Fig. 66 - Tighten handle

The ratchet levers are used for various locking functions on the **ROTIX** system. Occasionally, movement of the lever locking position is required. The lever placement can be adjusted by following these steps:

1. Pull the ratchet lever away from the base to which it is connected (Fig. 64).
2. Continue to pull while rotating the lever in the appropriate direction (Fig. 65).
3. Release the lever and utilize the new tightening position.

5.5. Probe Positioning System (PPS)

The probe positioning system (PPS) uses a linear rail and leadscrew system to position two or four probes for weld inspection. Used to adjust probe-to-probe spacing and allow the operator to center probes over the weld without removing the scanner. To operate a probe positioning system (see *Using a Probe Positioning System (PPS)* on page 54)

5.5.1. Installing a Probe Positioning System

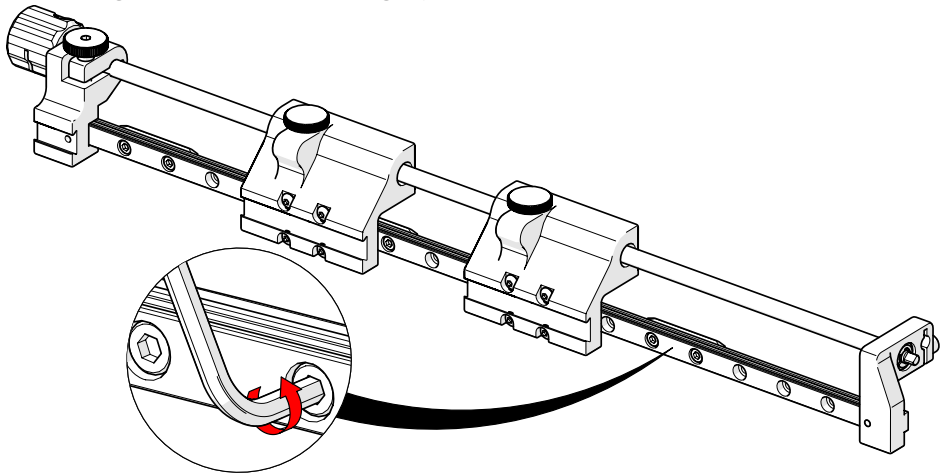

Fig. 67 - Slightly loosen all dovetail nuts

1. To install the PPS to a frame bar, ensure all the dovetail nuts are loose (Fig. 67) using a 2.5 mm hex wrench (Fig. 28).

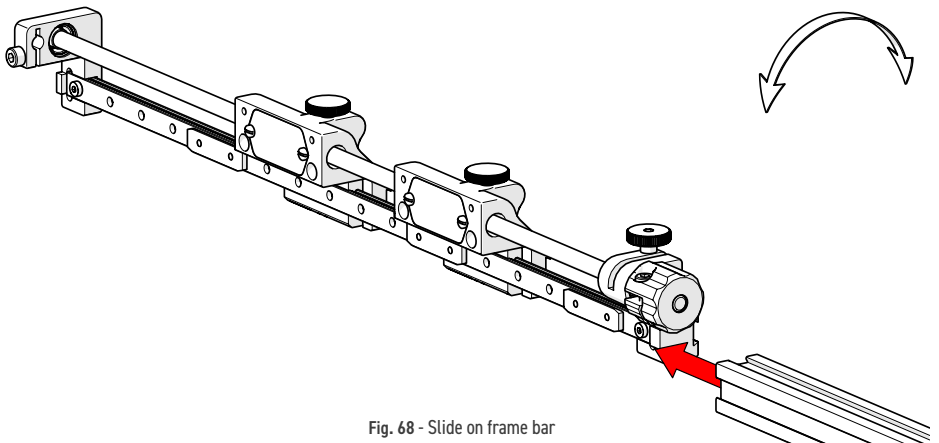

Fig. 68 - Slide on frame bar

2. Slide the assembly onto the frame bar (Fig. 68) and tighten the hexagonal screws in each dovetail nut (Fig. 69).

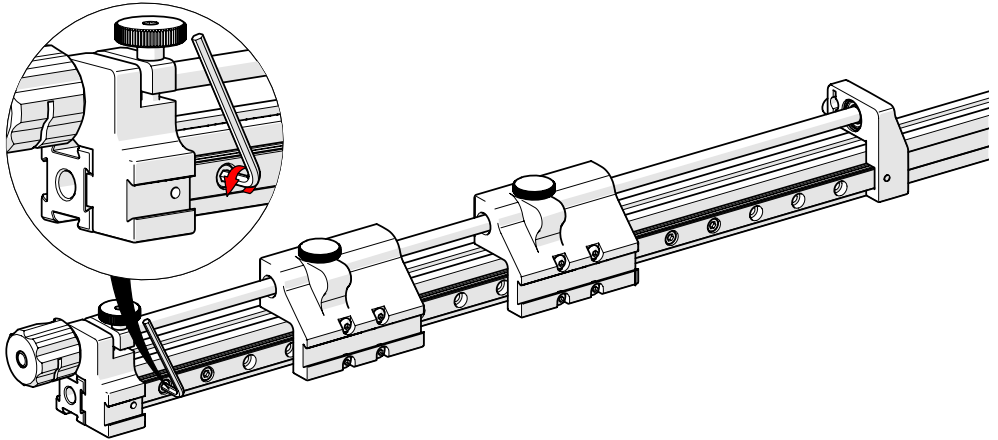

Fig. 69 - Tighten dovetail nuts along linear rail

TIP: In most applications, mounting the frame bar flush with the knob side of the PPS is recommended.

5.5.2. Four Probe Setup

It is possible to increase the probe holding capabilities of the probe positioning system to a four probe setup.

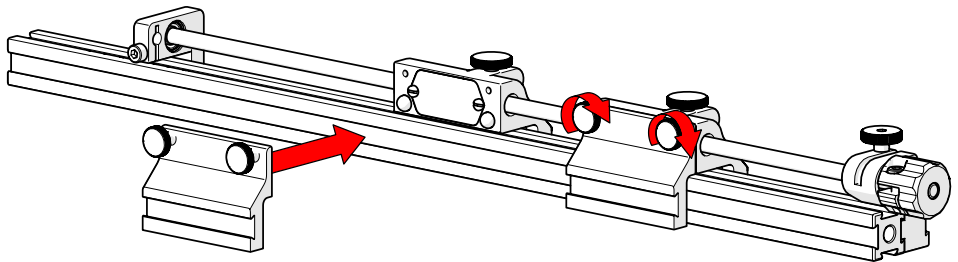

Fig. 70 - Position the probe holders and screw knobs tight

To attach the PPS slider backing plate, align the plate with the corresponding backing plate and tighten the two knobs (Fig. 70).

5.5.3. Index Encoding

The index encoder provides positional feedback perpendicular to the scan direction of travel.

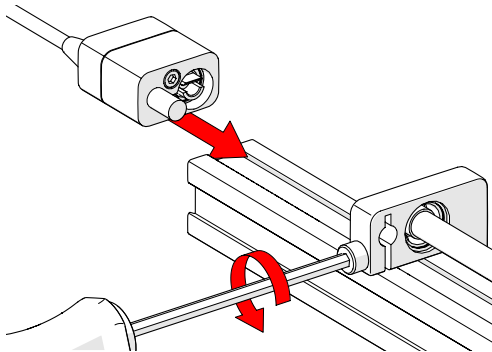

Fig. 71 - Loosen and slide post in place

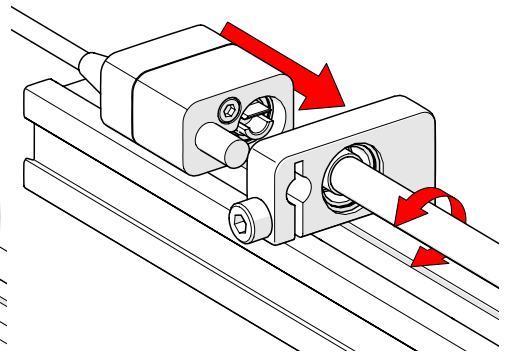

Fig. 72 - Align and mount post

1. To install the index encoder, loosen the clamp screw of the index encoder support bracket with the supplied 3 mm hex driver (Fig. 71).
2. Insert the encoder post in the index encoder support bracket while aligning the leadscrew shaft with the encoder socket (Fig. 72).

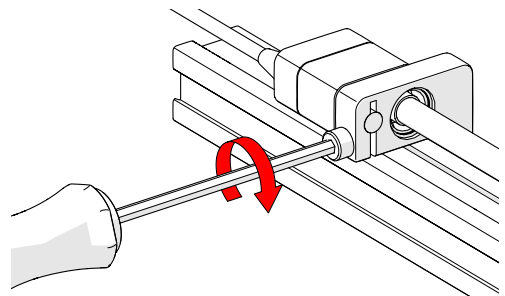

Fig. 73 - Tighten clamp screw

TIP: You can rotate the leadscrew by hand to assist in the alignment of the encoder socket.

3. Lock the encoder in place by tightening the 3 mm clamp screw on the index encoder support bracket (Fig. 73).
4. Plug the encoder connector into the auxiliary connector on the cart (Fig. 74).

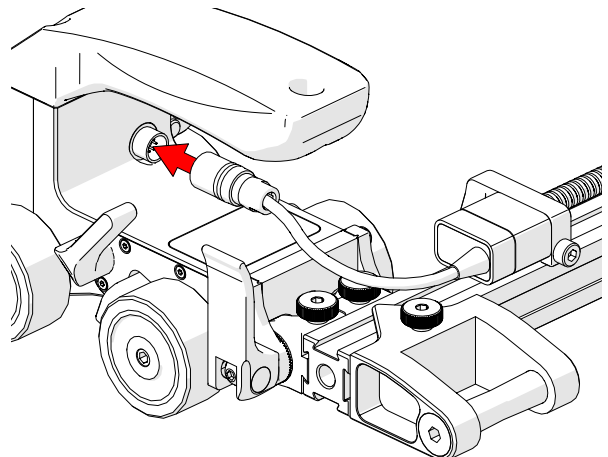
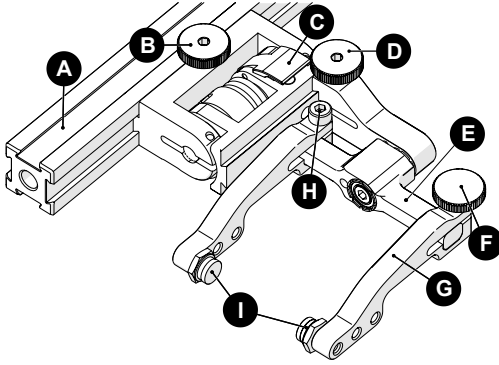

Fig. 74 - Connect encoder to umbilical

5.6. Slip Joint Probe Holder



A	Frame Bar
B	Probe Holder Adjustment Knob
C	Latch
D	Swing Arm Knob
E	Yoke
F	Probe Holder Arm Adjustment Knob
G	Probe Holder Arm
H	Arm Clamp Screw
I	Pivot Buttons

Fig. 75 - Slip Joint Probe Holder

5.6.1. Probe Holder Setup

To mount a UT wedge in the probe holder, follow these steps:

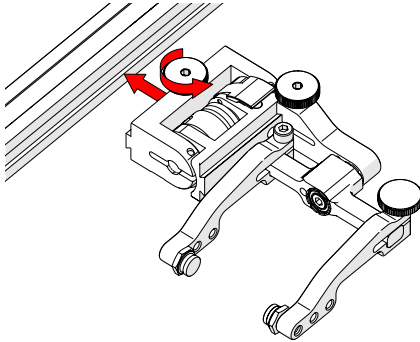

Fig. 76 - Attach to frame bar

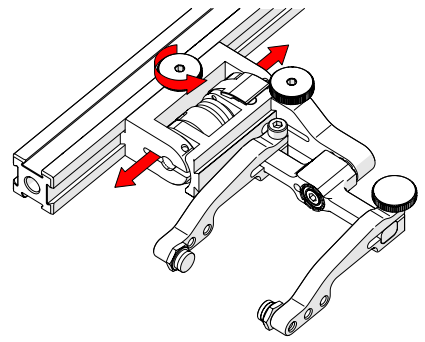

Fig. 77 - Adjust on frame bar

1. Rotate the probe holder adjustment knob and attach the probe holder to a frame bar (Fig. 76).
2. Use the probe holder adjustment knob to position the probe holder along the frame bar (Fig. 77).

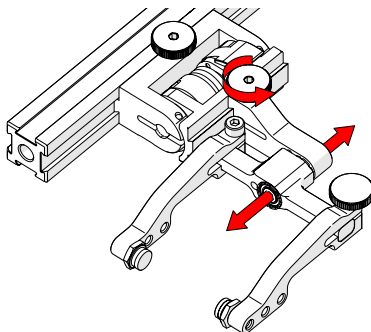

Fig. 78 - Adjust swing arm

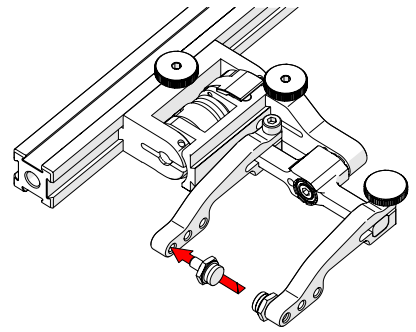

Fig. 79 - Place pivot buttons

3. Use swing arm knob to position the swing arm (Fig. 78).

TIP: The swing arm is typically used to adjust TOFD center-to-center distance relative to the phased array probes on a four probe configuration (Fig. 35).

4. Using the supplied 3/8 in wrench (Fig. 25), place the pivot buttons as required (Fig. 79).

TIP: If a narrow scanning footprint is required, use pivot button holes closest to the yoke. Wedge pivoting may be impeded when closer to the yoke.

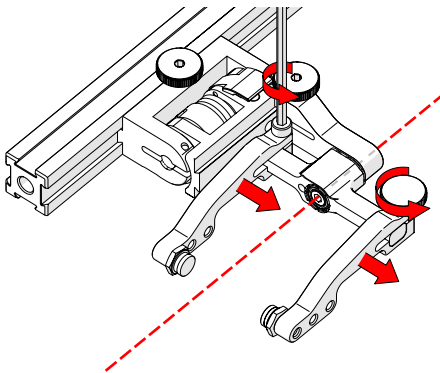

Fig. 80 - Adjust probe holder arms

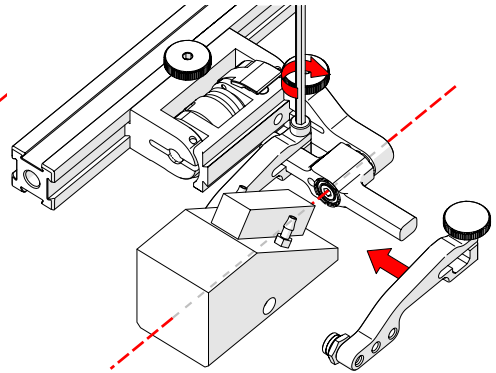

Fig. 81 - Place wedge

5. Loosen the arm clamp screw and the probe holder arm adjustment knob (Fig. 80), and remove the outer probe holder arm from the yoke.
6. Adjust the inner probe holder arm as required to best centre the probe on the yoke's pivot axis (Fig. 80).

TIP: The probe holder yoke can accommodate many different probe and wedge sizes of varying widths. It is best to centre the wedge with the yoke's pivot axis to reduce wedge tipping when scanning. Position the inner probe holder arm accordingly with the centre of the yoke (Fig. 80).

7. Position the wedge on the inner probe holder arm (Fig. 81).
8. Tighten the arm clamp screw (Fig. 81).
9. Slide the outer probe holder arm along the yoke pinching the wedge in place.
10. Tighten the probe holder arm adjustment knob (Fig. 82).

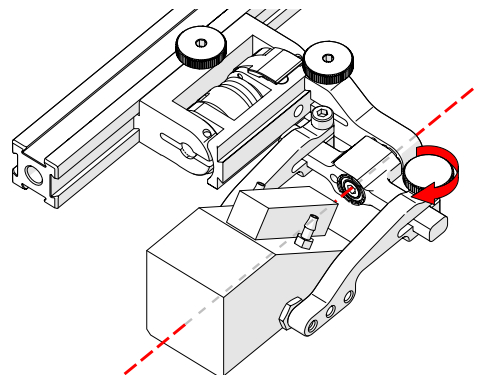

Fig. 82 - Pinch wedge with arm

5.6.2. Probe Holder Adjustment

To adjust the probe holder, follow these steps:

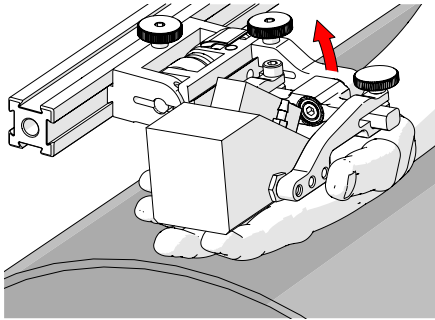

Fig. 83 - Lift to Latched position

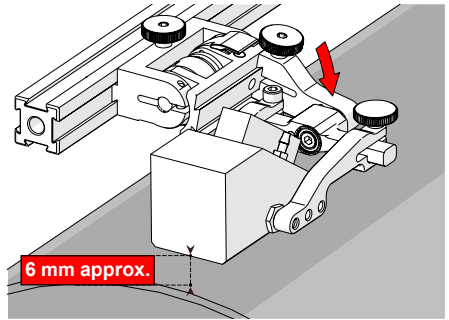

Fig. 84 - Lower to scanning surface

1. Ensure the probe holder is in latched, upper position (Fig. 83). If the probe holder is already latched, it will only move within the slip joint adjustment range and have no spring tension.
2. Push the probe holder yoke down toward the inspection surface until the wedge is approximately 6 mm ($\frac{1}{4}$ in) above the inspection surface (Fig. 84).

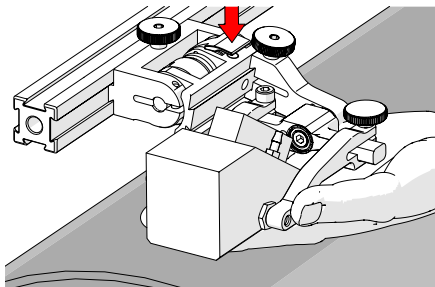

Fig. 85 - Lift and press latch button

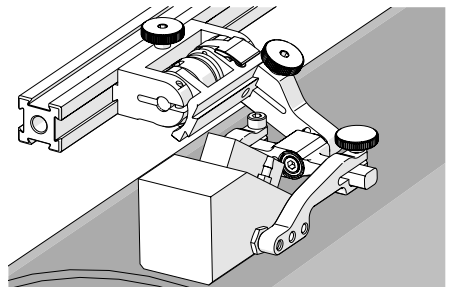

Fig. 86 - Spring loaded scan position

3. Lift the probe slightly and press the latch button (Fig. 85) to apply spring pressure to the wedge.
4. Gently lower the probe holder and wedge to the scanning surface (Fig. 86).

5.6.3. Probe Holder Force Adjustment

It is possible to adjust the tension of the probe holder spring.

NOTE: The 2 mm hex wrench (Fig. 27) and 3 mm hex wrench (Fig. 29) are required to perform this operation.

Light	1 kg	2 lb
Medium	2 kg	4 lb
Heavy	3 kg	6 lb

When configured correctly, these settings exert the indicated spring force on the Probe.

To adjust the probe holder's force, follow these steps:

NOTE: Do not perform this operation on a scanning surface.

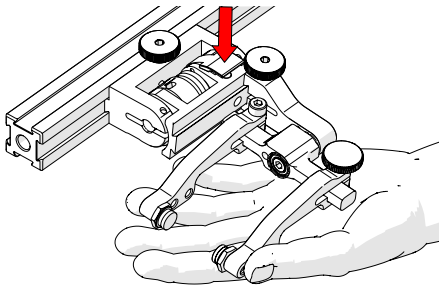

Fig. 87 - Lift slightly and press latch

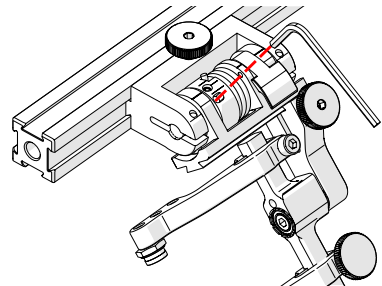

Fig. 88 - Unlatched position

1. Ensure the probe holder is in the upright latched position (Fig. 83).
2. Lift the probe holder slightly and press the latch button (Fig. 87) to release the probe holder the full 45° degrees.
3. Insert the short arm of a 3 mm hex wrench into the 3 mm slot (Fig. 88).

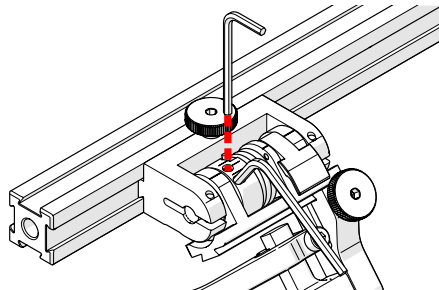

Fig. 89 - Insert hex wrenches

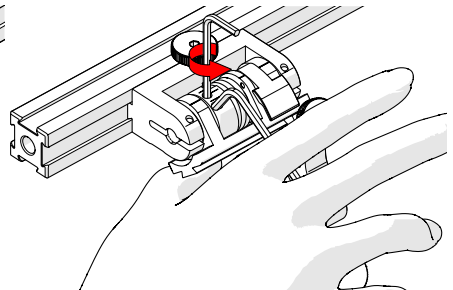

Fig. 90 - Press 3 mm hex wrench down

4. Place the 2 mm hex wrench into the force adjustment screw (Fig. 89).
5. Lightly press the long arm of the 3 mm hex wrench down. Using the 2 mm hex wrench, loosen the force adjustment screw but do not remove it (Fig. 90).
6. Gently apply pressure on the long leg of the 3 mm hex wrench until the force adjustment marker lines up with the desired spring tension. While keeping the markers in line, tighten the force adjustment screw (Fig. 91).

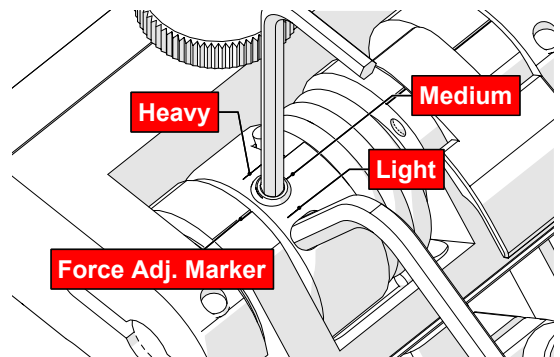

Fig. 91 - Choose desired tension

5.6.4. Slip Joint Probe Holder Left/Right Conversion

To reverse the probe holder, follow these steps:

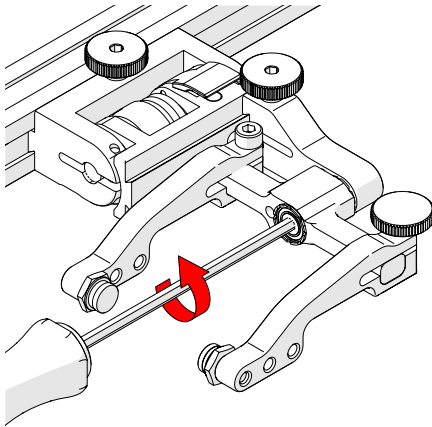

Fig. 92 - Unscrew yoke pivot screw

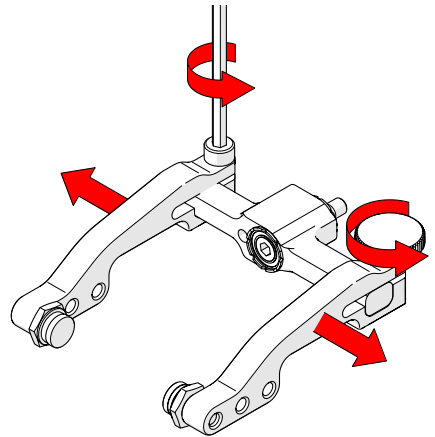

Fig. 93 - Remove arms

1. Unscrew the yoke from the swing arm (Fig. 92).
2. Loosen the probe holder arm adjustment knob and arm clamp screw. Slide the arms from the yoke (Fig. 93).

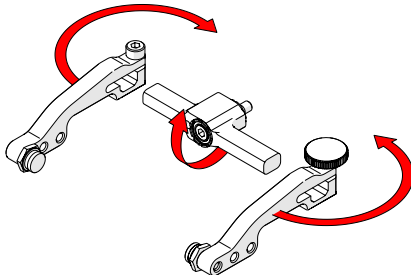

Fig. 94 - Flip yoke and reverse arms

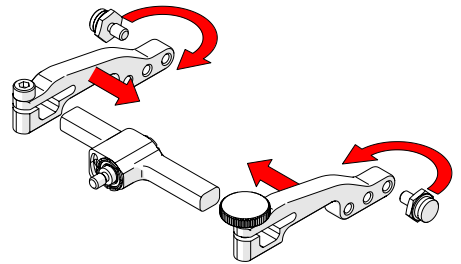

Fig. 95 - Attach arms and move buttons

3. Flip the yoke 180° and reverse the probe holder arms (Fig. 94).
4. Place the pivot buttons on the inside of the probe holder arms (Fig. 95) using a 3/8 in wrench (Fig. 25). Slide the arms onto the yoke and tighten the probe holder arm adjustment knob and the arm clamp screw.

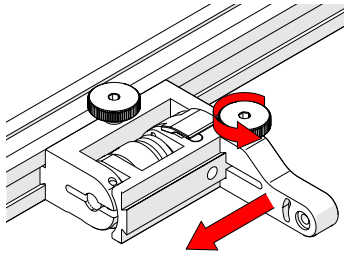

Fig. 96 - Position swing arm

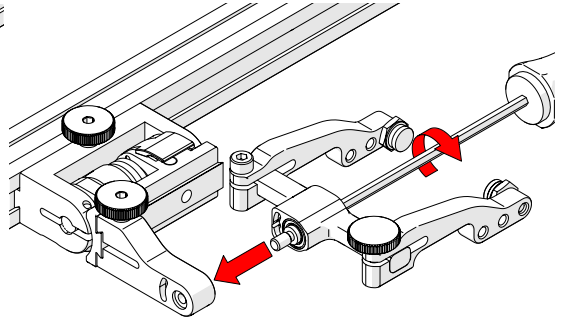

Fig. 97 - Install yoke to swing arm

5. Loosen the swing arm knob and slide the swing arm to the opposite end of the probe holder bracket (Fig. 96) or the preferred position. Tighten the swing arm knob.
6. Using the 3 mm hex driver, screw the yoke pivot screw into the opposite side of the probe holder swing arm (Fig. 97). Ensure the yoke is level to avoid issues with the plunger/set screw.

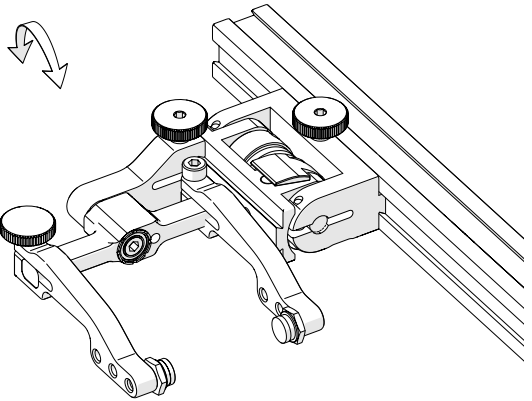

Fig. 98 - Reversed probe holder

5.6.5. Pivot Buttons

Available in a variety of shapes and sizes, fitting various wedge dimensions.

Use the supplied 3/8 in wrench (Fig. 25) to remove and install pivot buttons in desired hole location (Fig. 99).

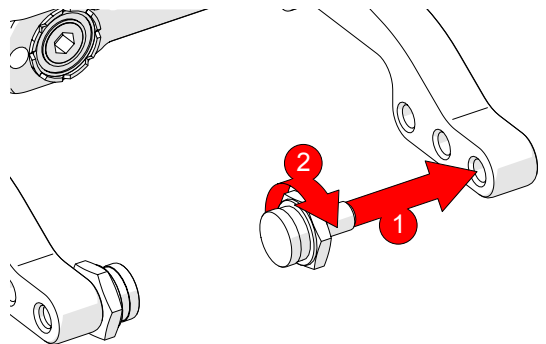

Fig. 99 - Pivot buttons

5.7. Cable Management System

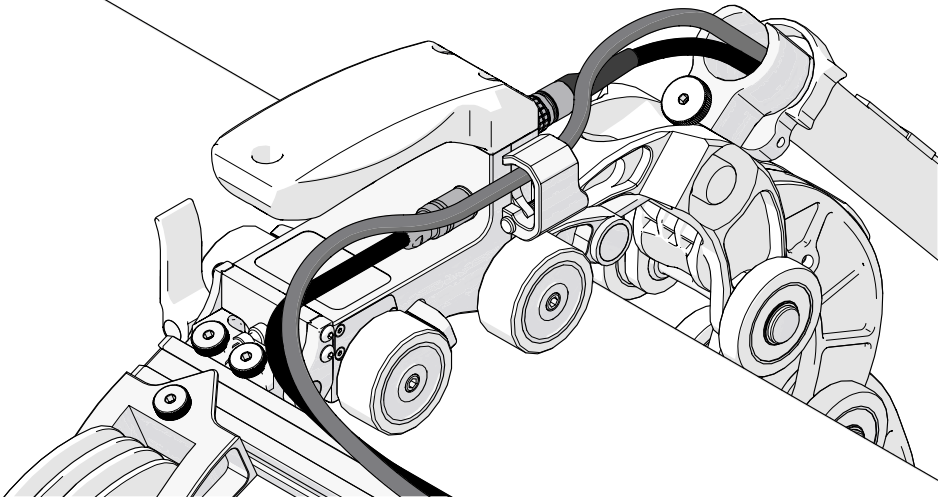

Fig. 100 - Cable management

The cable management provides a means of bundling and protecting cables and hoses that connect to the scanner.

5.7.1. Cable Management Dovetail Mount

To attach cable management, follow these steps:

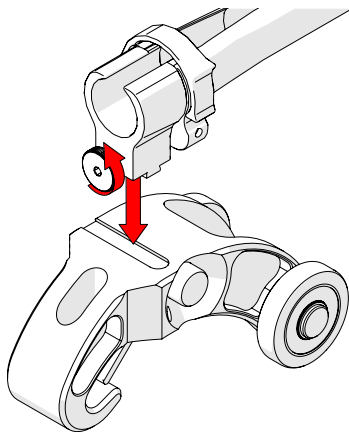

Fig. 101 - Loosen and slide on

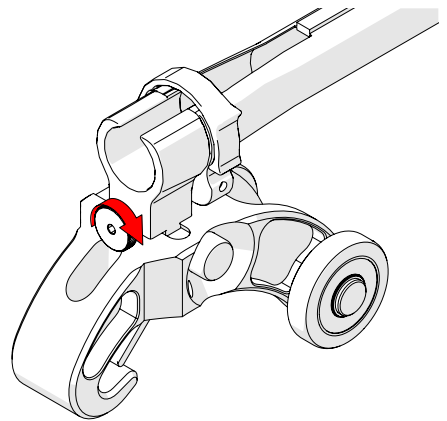

Fig. 102 - Tighten knob

1. Loosen the knob on the cable management dovetail mount. Position the mount onto the Dovetail QuickLink (Fig. 101).
2. Once centred on the Dovetail QuickLink, tighten the cable management's dovetail mount knob (Fig. 102).

5.7.2. Cable Management Setup

Cable management is available in a variety of lengths and provides a means of bundling and protecting cables and hoses that run to a scanner.

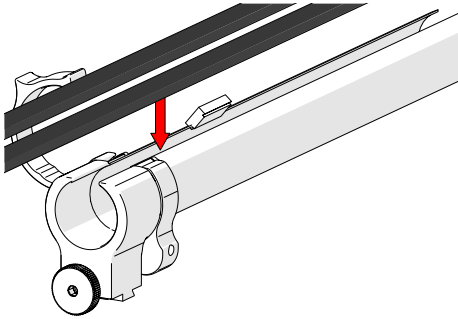

Fig. 103 - Insert cables and hoses

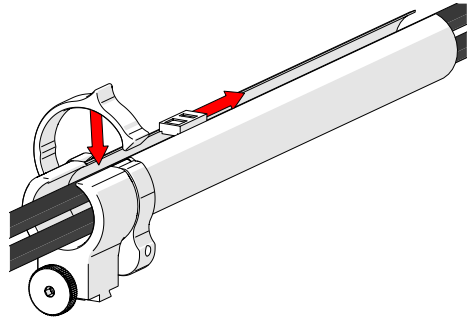

Fig. 104 - Zip up to close

1. Open the zipper of the cable management. Begin at the tube's dovetail mount and place the cabling in the tube (*Fig. 103*).
2. Follow the cable placement, zipping the tube closed (*Fig. 104*).

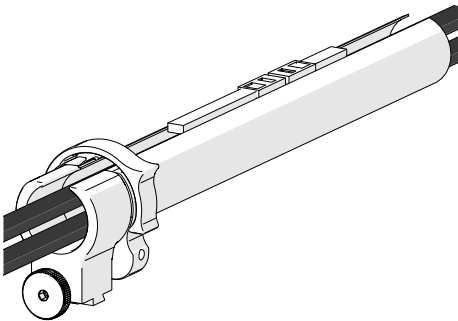

Fig. 105 - Zip opposite end

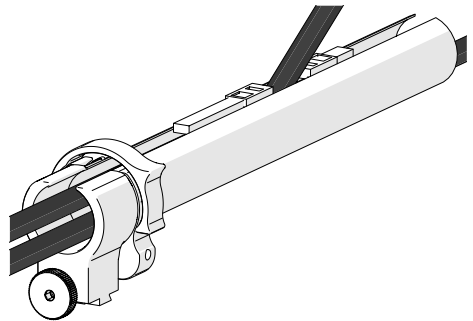

Fig. 106 - Flexibility

3. Once the cable is placed the entire length of the tube, bring the zipper from the tube's opposite end, meeting at any point in the middle (*Fig. 105*).
4. When necessary, the two zippers may be opened to allow cables to exit the tube anywhere between the ends (*Fig. 106*).

5.7.3. Clamp Setup

If the tube becomes disconnected from the cable management dovetail mount, follow these instructions to re-attach the tube and dovetail mount.

1. Loosen the clamp screw using the supplied 3 mm hex driver.
2. Slide the clamp around the tube first and then slide the tube around the outside of the cable management dovetail mount (*Fig. 107*). Align the zipper opening and the cable management dovetail mount opening.
3. Slide the clamp over the tube and cable management dovetail mount, pinching the tube in between (*Fig. 108*).
4. Tighten the clamp screw (*Fig. 109*).

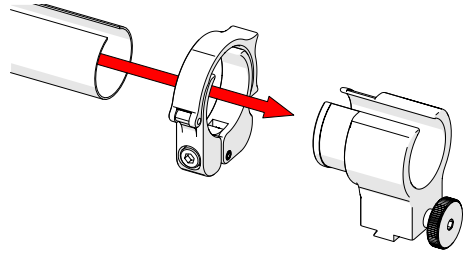

Fig. 107 - Slide tube around mount

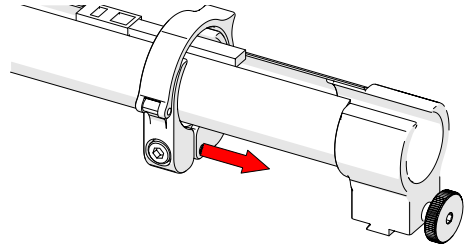

Fig. 108 - Slide clamp onto mount

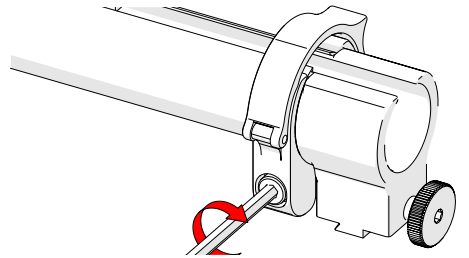

Fig. 109 - Tighten clamp screw

5.8. Reduced Width Scanning Kit

The encoded probe holding link houses the main encoder and provides a mounting base for probe holders.

To mount/adjust the frame bar, loosen the bar adjustment knobs, insert the bar, slide to desired placement, then tighten the bar adjustment knobs.

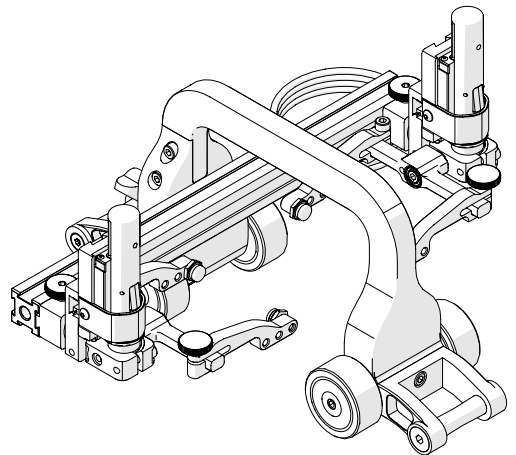

Fig. 110 - Reduced width scanning kit

5.9. Vertical Probe Holder

- A Latch
- B Probe Holder Adjustment Knob
- C Vertical Adjustment Knob
- D Pivot Buttons
- E Probe Holder Arms
- F Yoke
- G Probe Holder Arm Adjustment Knob
- H Transverse Adjustment Screw
- I Frame Bar

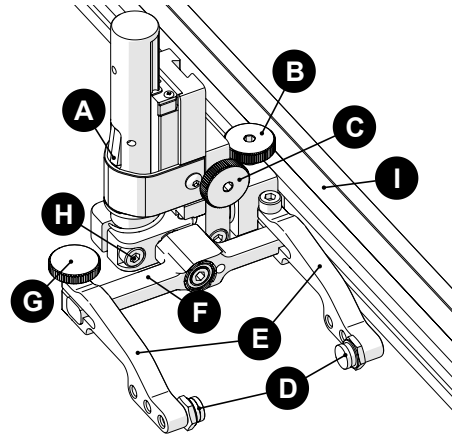

Fig. 111 - Vertical probe holder

5.9.1. Probe Holder Setup

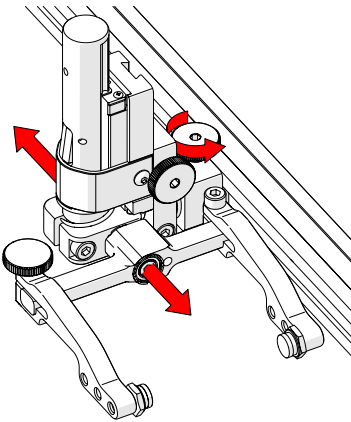

Fig. 112 - Adjust on frame bar

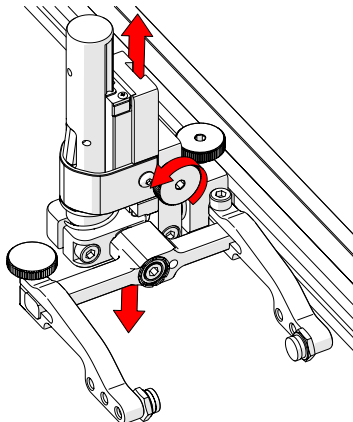

Fig. 113 - Vertical adjustment

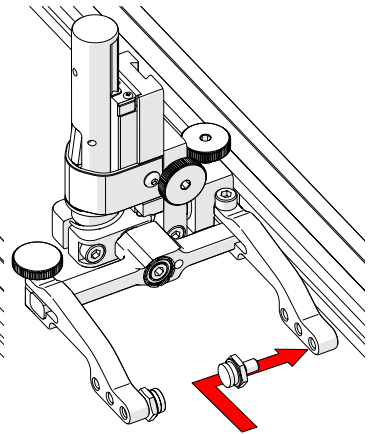

Fig. 114 - Place buttons

1. The probe holder adjustment knob allows the probe holder to be attached to a frame bar, as well as horizontal positioning on a frame bar (Fig. 112).
2. The vertical adjustment knob allows the vertical probe holder height adjustment (Fig. 113).
3. Position the pivot buttons where necessary (Fig. 114). When a narrow scanning footprint is required, use the pivot button holes closest to the yoke.

TIP: Probe pivoting may be impeded when closer to the yoke.

To mount a UT wedge in the probe holder, follow these steps

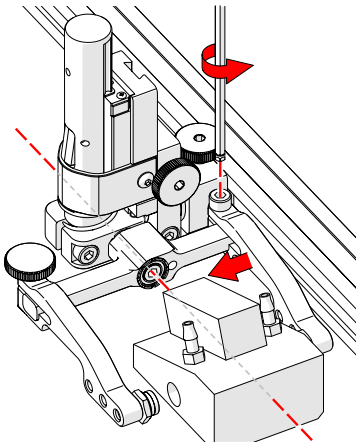

Fig. 115 - Adjust inner arm

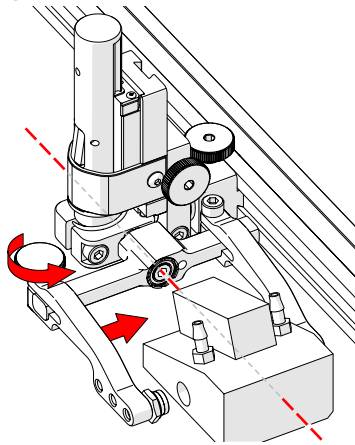

Fig. 116 - Adjust outer arm

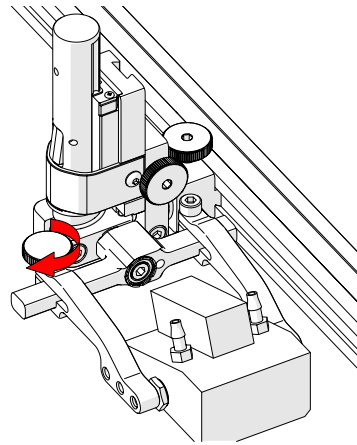

Fig. 117 - Tighten arm knob

4. Position the wedge on the inner probe holder arm.

TIP: The probe holder yoke can accommodate many different probe and wedge sizes of varying widths. It is best to centre the wedge with the yoke's pivot axis. This can reduce wedge tipping when scanning. Position the inner probe holder arm accordingly (Fig. 115) using the supplied 3 mm hex driver (Fig. 24).

5. Loosen the probe holder arm adjustment knob (Fig. 116) and slide the probe holder arm along the yoke pinching the wedge in place.
6. Tighten the probe holder arm adjustment knob (Fig. 117).

5.9.2. Probe Holder Vertical Adjustment

To adjust the probe holder vertically, follow these steps:

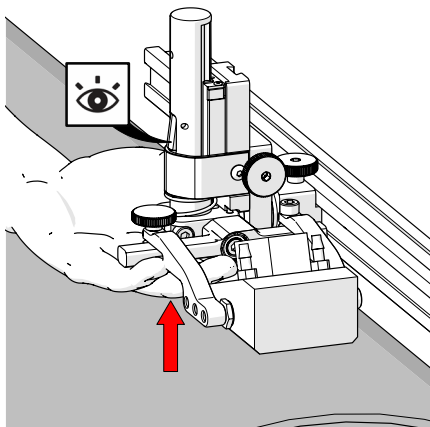

Fig. 118 - Latch probe holder

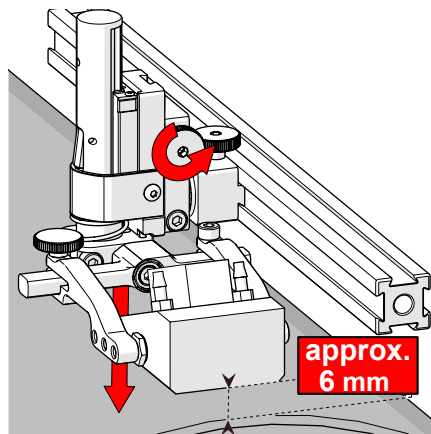

Fig. 119 - Lower toward scan surface

1. Ensure the probe holder is in the latched upper position. Do this by lifting the probe holder till the latch is fully exposed (Fig. 118).
2. Loosen the vertical adjustment knob and slide the probe holder down until the wedge is approximately 6 mm ($\frac{1}{4}$ in) above inspection surface (Fig. 119).
3. Tighten the vertical adjustment knob.

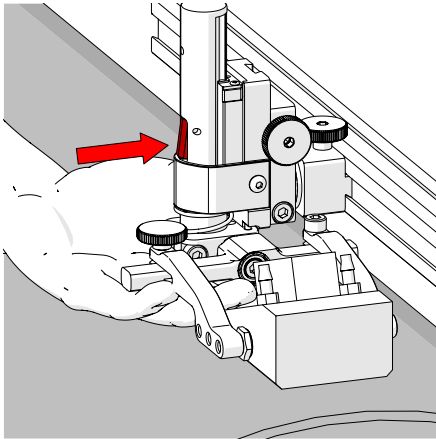

Fig. 120 - Press latch button

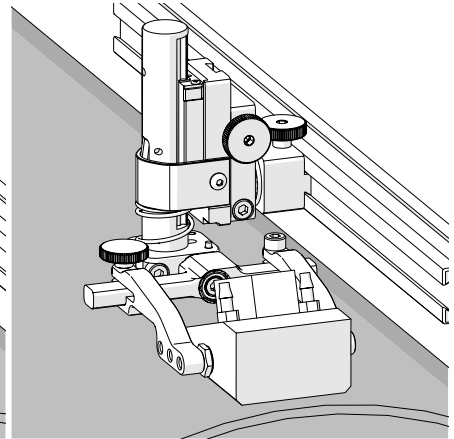

Fig. 121 - Lower toward scan surface

4. Lift the yoke slightly and press the latch button (Fig. 120), then slowly lower towards scanning surface to apply spring pressure to the wedge (Fig. 121).

TIP: If less spring force is desired, refer to step 2 and place the wedge approximately 20 mm ($\frac{3}{4}$ in) above the inspection surface.

5.9.3. Probe Holder Transverse Adjustment

To adjust the probe holder's transverse angle, follow these steps:

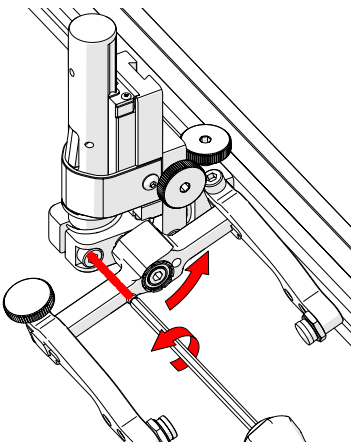

Fig. 122 - Loosen 3 mm screw

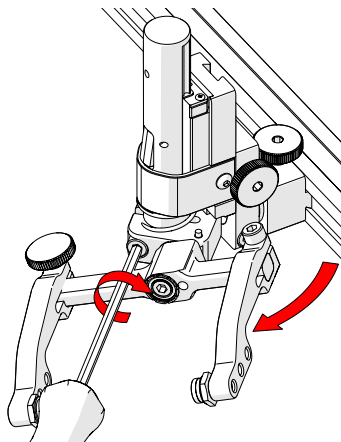

Fig. 123 - Rotate and tighten

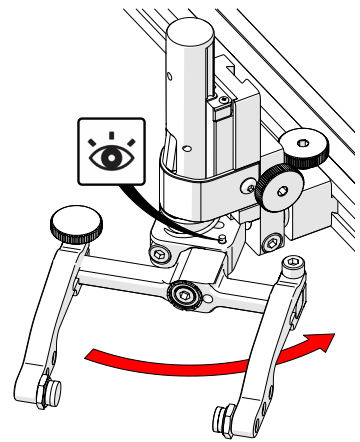

Fig. 124 - Stop post locates 90°

1. Ensure the probe holder is in latched upper position (*Fig. 118*).
2. Using the supplied 3 mm hex driver loosen the transverse adjustment screw (*Fig. 122*) and rotate the yoke about the vertical shaft achieving the desired angle.
3. Tighten the transverse adjustment screw (*Fig. 123*).

To return the transverse adjustment to neutral (90°). The probe holder must be in the latched, upper position (*Fig. 118*). Rotate the yoke until the stop post contacts the base of the probe holder (*Fig. 124*). Then tighten the transverse adjustment screw.

5.9.4. Probe Holder Longitudinal Adjustment

To adjust the probe holder's vertical angle for longitudinal scanning, follow these steps:

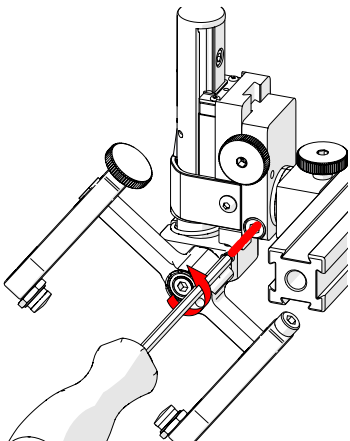

Fig. 125 - Loosen 3 mm screw

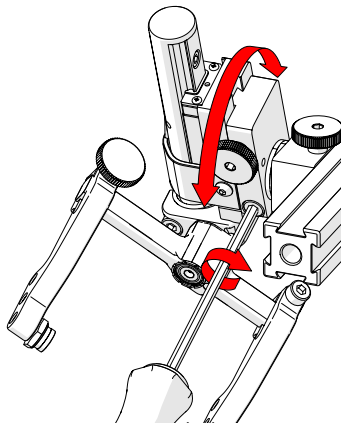

Fig. 126 - Rotate to position

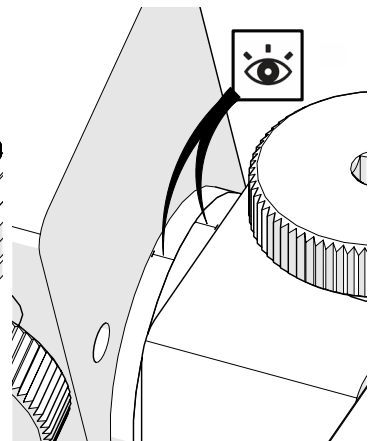

Fig. 127 - Line up markers

1. Ensure the probe holder is in latched, upper position (*Fig. 118*).
2. Using the supplied 3 mm hex driver (*Fig. 24*), loosen the longitudinal adjustment screw (*Fig. 125*).
3. Rotate the main body of the probe holder until it is at the desired angle.
4. Tighten the longitudinal adjustment screw (*Fig. 126*).

To return the longitudinal adjustment to neutral (90°). Line up the longitudinal adjustment indicator markers (*Fig. 127*).

5.9.5. Probe Holder Left/Right Conversion

To reverse the probe holder, follow these steps:

NOTE: The 1.5 mm hex wrench (Fig. 26) is required to perform this operation.

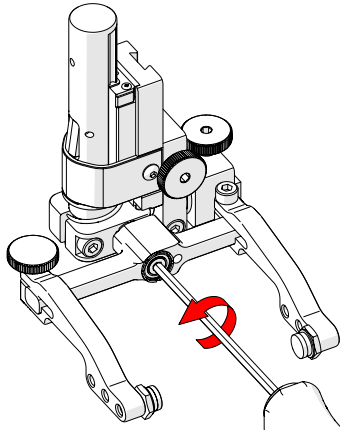

Fig. 128 - Unscrew yoke pivot screw

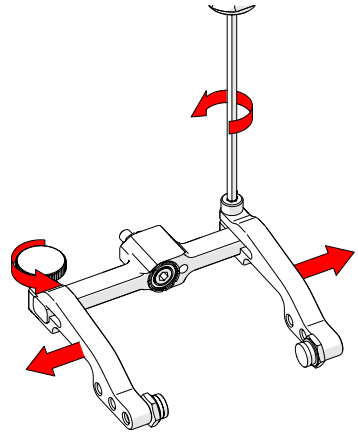

Fig. 129 - Remove probe holder arms

1. Ensure the probe holder is in latched, upper position (Fig. 118).
2. Using the supplied 3 mm hex driver (Fig. 24), unscrew the yoke pivot screw and remove the yoke (Fig. 128).
3. Loosen the probe holder arm adjustment knob and the arm clamp screw. Slide the probe holder arms off the yoke (Fig. 129).

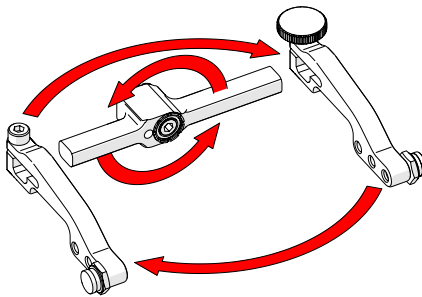

Fig. 130 - Flip yoke and reverse arms

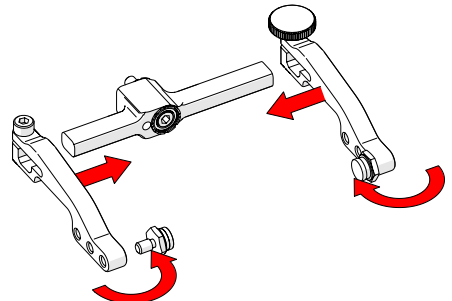

Fig. 131 - Attach arms & move buttons

4. Flip the yoke 180° and reverse the probe holder arms (Fig. 130).
5. Place the pivot buttons on the inside of the probe holder arms (Fig. 131) using a 3/8 in wrench (Fig. 25).

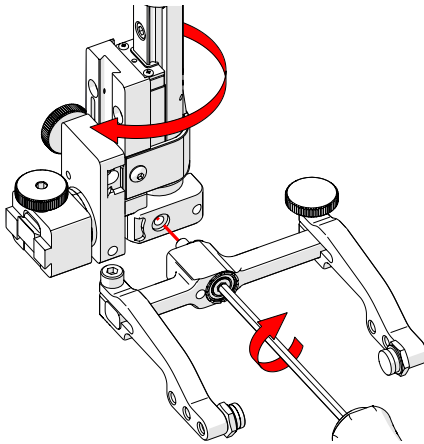

Fig. 132 - Screw yoke to opposite side

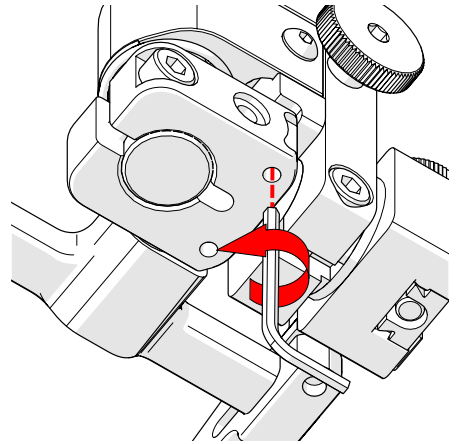

Fig. 133 - Lower 90° stop post

6. Mount the yoke to the opposite side of the base using the supplied 3 mm hex driver (Fig. 132).

TIP: Keep the yoke level with the base to ensure no conflicts with the plunger/set screw attached to the yoke.

7. Locate the recessed M3 screw (stop post) on the bottom of the probe holder. Unscrew the stop post using a 1.5 mm hex wrench until it has cleared all obstructions. Do not remove the stop post (Fig. 133).

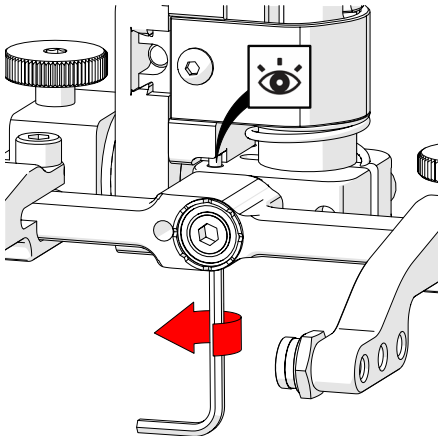

Fig. 134 - Raise opposite 90° stop post

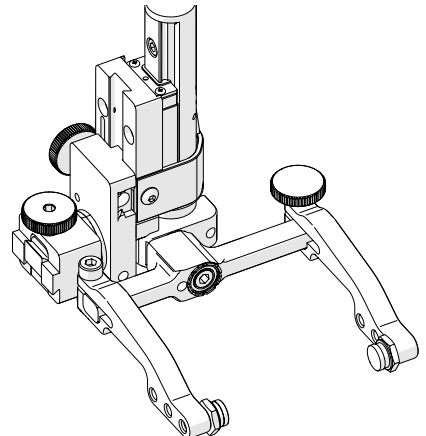

Fig. 135 - Reversed probe holder

8. Raise the stop post on the opposite side until the side of the post contacts the 90° stop point on the probe holder's base (Fig. 134).

5.10. Magnetic Wheel Kit



WARNING! MAGNETIC MATERIAL. The magnetic wheel kit produce a magnetic field which may cause failure or permanent damage to items such as watches, memory devices, CRT monitors, medical devices or other electronics. People with pacemakers or ICD's must stay at least 25 cm (10 in) away.

When a chain scanner is not appropriate, the magnetic wheel kit (Fig. 136) can replace the non-magnetic wheels on a **ROTIX** scanner body. Two magnetic wheel kits can also be used on the cart body to double the magnetic force.

To install or remove wheels (see *Wheel Removal/Installation* on page 18).

NOTE: Do not use magnetic wheels with a chain assembly.

NOTE: Magnetic wheels may lose their magnetic properties if heated above 175° F (80° C).

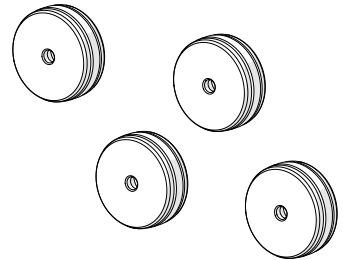

Fig. 136 - Magnetic wheel kit

5.11. Single PPS

Similar to the standard probe positioning system. The single PPS (Fig. 137) is commonly used for corrosion mapping. Use an additional backing plate to allow for two probe scanning. To install and set up (see *Probe Positioning System (PPS)* on page 26).

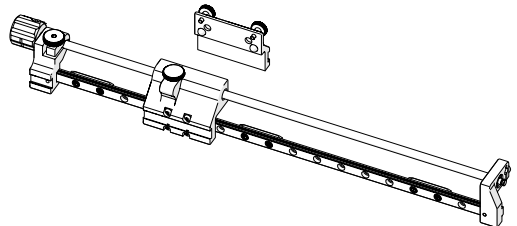

Fig. 137 - Single probe positioning system

5.12. Slider Probe Positioning System

The slider probe positioning system uses a slide and leadscrew system to position one or two probes for weld inspection. This system can set the probe center spacing and allows the operator to center the two probes over the weld without removing the scanner. To operate a slider PPS (see *Using a Slider Probe Positioning System (Slider PPS)* on page 57)

5.12.1. Slider PPS Assembly

To assemble a slider probe positioning system, follow these steps:

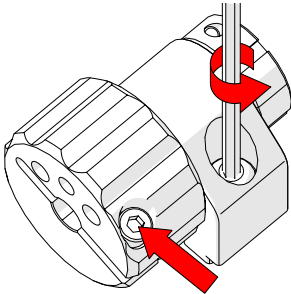

Fig. 138 - Loosen screws

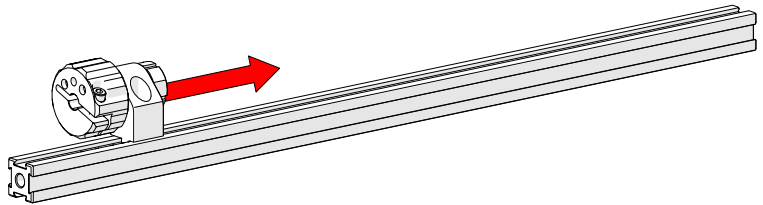

Fig. 139 - Slide main knob to middle of frame bar

1. Ensure the lock screw and the hexagonal screw in the main knob are loose (Fig. 138).
2. Slide the main knob to the middle of the frame bar (Fig. 139).

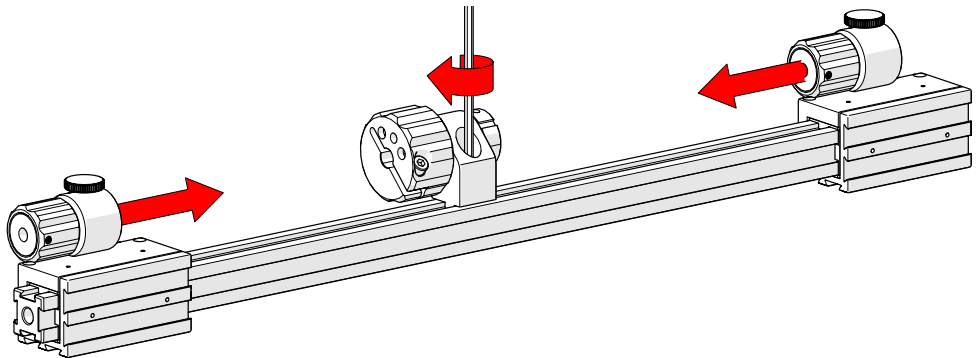

Fig. 140 - Attach slide assemblies and tighten lock screw

3. Tighten the lock screw on the main knob bracket (Fig. 140). Ease the two sliders onto either end of the frame bar and push the sliders to the desired position on the frame bar (Fig. 140). The slider's friction fit requires an appropriate level of force to position the sliders.

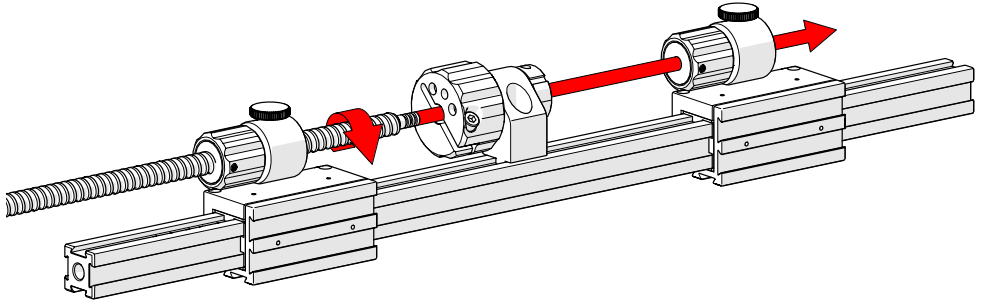

Fig. 141 - Screw leadscrew into place

4. Screw the leadscrew into the first slider, then the main knob and finally the 2nd slider assembly (Fig. 141).

NOTE: The leadscrew's encoder end must be positioned on the same side as the cart.

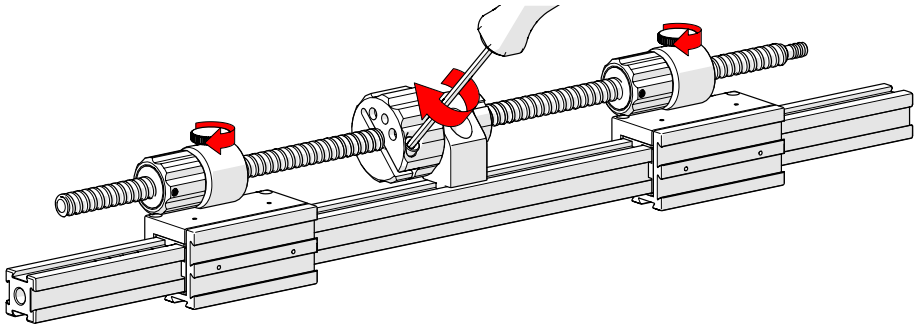

Fig. 142 - Tighten hexagonal screw

5. Tighten the main knob's hexagonal screw (Fig. 142).

5.12.2. Slider Index Encoding

The slider index encoder provides positional feedback perpendicular to the scan direction of travel. Follow these steps for installation:

1. Ensure the encoder's lock screw is loose.

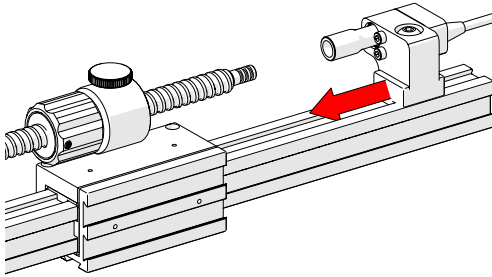

Fig. 143 - Loosen and slide post in place

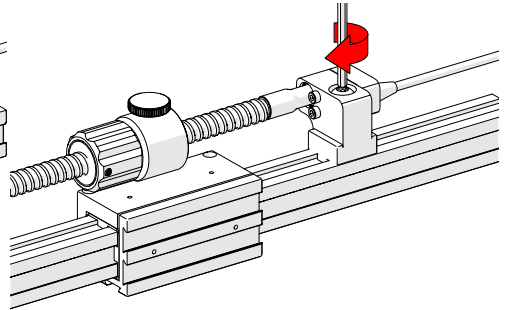

Fig. 144 - Align and mount post

2. Slide the encoder's dovetail nut onto the frame bar (Fig. 143), and continue sliding the encoder towards the leadscrew until the leadscrew and the encoder's coupling are attached (Fig. 144).
3. Tighten the encoder's lock screw (Fig. 144).

TIP: Leave space for the pivot nose and QuickLink Mounting Bracket when placing the encoder on the frame bar. If necessary, repeat the slider PPS installation (see Slider PPS Assembly on page 45) sequence and position the system with space for the QuickLink Mounting Bracket.

5.13. Crank Handle

Used in conjunction with a single probe with slider PPS setup (Fig. 36). The crank handle provides faster probe positioning and greater ease of use. To install the crank handle, follow these steps:

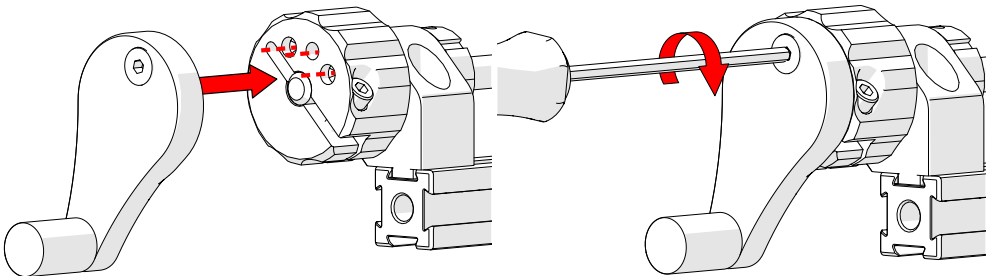

Fig. 145 - Align posts

Fig. 146 - Tighten screw

1. Align the dowels of the crank handle with the holes of the main knob (Fig. 145).
2. Using the supplied 3 mm hex driver (Fig. 24), tighten the hexagonal screw (Fig. 146).

5.14. Preamp Bracket

Compatible with most standard preamps, use screws or the optional velcro straps to attach a preamp to the preamp bracket.

Intended Use

- ▶ The preamp bracket is intended to mount objects (*e.g. preamps, splitters, etc.*) that:
- ▶ have a maximum weight of 1.36 kg (3 lb)
- ▶ are attached to the with a lanyard or probe cables strong enough to prevent the object from falling
- ▶ have smooth edges so as not to cut the bracket's velcro strap

5.14.1. Mounting Preamp Bracket

The preamp bracket mounts to any dovetail groove.

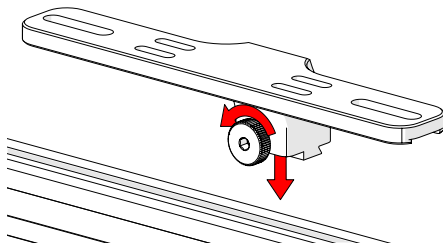

Fig. 147 - Loosen knob and mount to dovetail groove

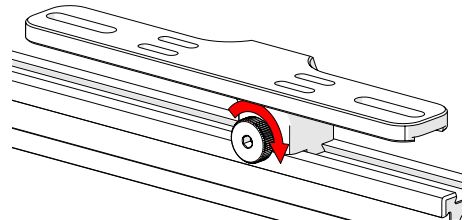

Fig. 148 - Tighten knob

1. Loosen the knob and align dovetail nut with the dovetail groove (*Fig. 147*).
2. Tighten the knob to lock the preamp bracket in place (*Fig. 148*).

5.14.2. Attaching Preamp with Screws

Use the adjustable screw mounting channel on the bottom of the bracket to attach a preamp (*screws not included*).

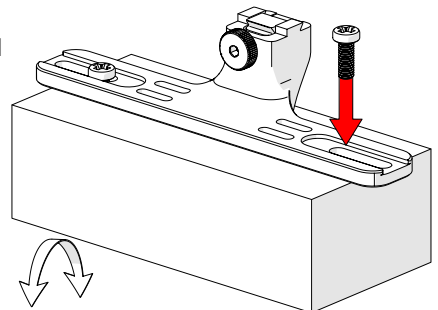

Fig. 149 - Attach preamp with screws

5.14.3. Attaching Preamp with Velcro Straps

To attach the preamp to the bracket using velcro straps (*sold separately*), follow these steps:

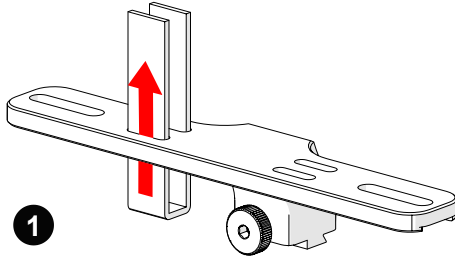

Fig. 150 - Insert velcro straps

1. Slide the velcro strap through the bracket's holes (*Fig. 150*).
2. Centre and place the preamp on the bracket wrapping the velcro around the preamp (*Fig. 151*).
3. Secure the preamp to the bracket attaching each side of the velcro (*Fig. 152*).

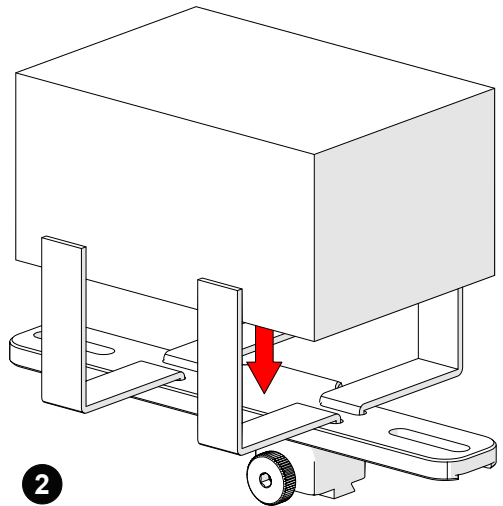

Fig. 151 - Place preamp and wrap velcro

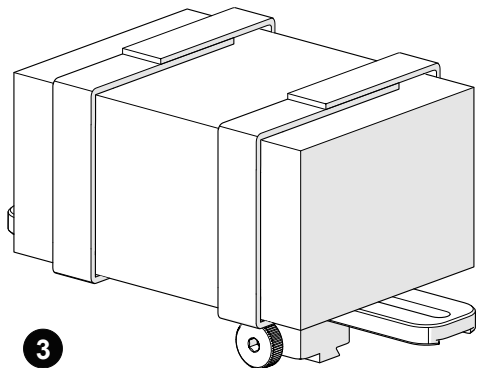
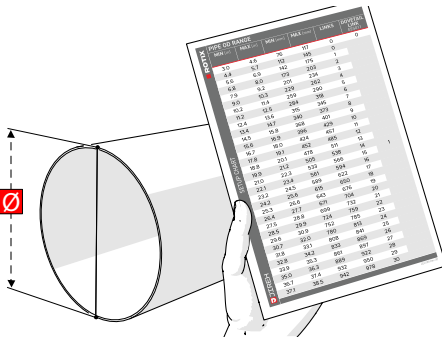

Fig. 152 - Mount bracket on a frame bar

OPERATION

6.1. Setup of ROTIX on Scanning Surface



TIP: This example is a two probe, single axis configuration for a 30.6 cm (12 in) pipe diameter.

3. On a flat surface, connect the appropriate amount of QuickLinks as indicated on the **ROTIX** setup chart. Arrange the configuration so the QuickLink Buckle will be 180° opposite the cart body (Fig. 155).

TIP: Place the Dovetail QuickLink directly behind the cart body to mount cable management.

4. Ensure the cart's brake is locked (see Brake Handle on page 17).
5. Drape the configured assembly around the pipe that will be inspected (Fig. 156).

TIP: Use caution when placing the assembly on the scan surface. The magnetized stabilizer wheel can lurch towards the metal suddenly.

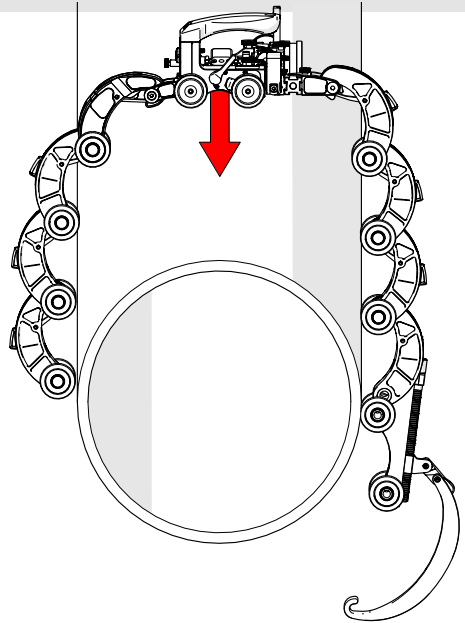

Fig. 156 - Drape onto pipe

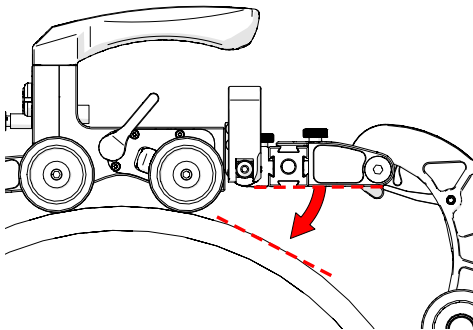

Fig. 157 - Lower pivot nose

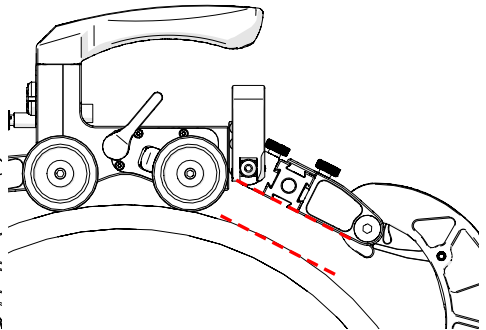

Fig. 158 - Parallel with scan surface tangent

6. Adjust the pivot nose (Fig. 157) angle to align the frame bar parallel with the tangent of the scan surface (Fig. 158).

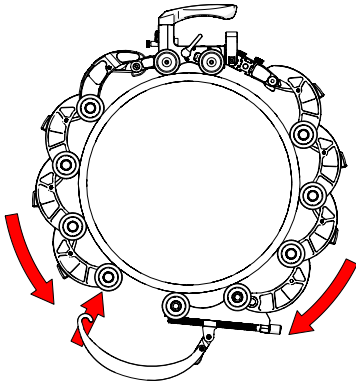

Fig. 159 - Hook QuickLink Buckle to QuickLink

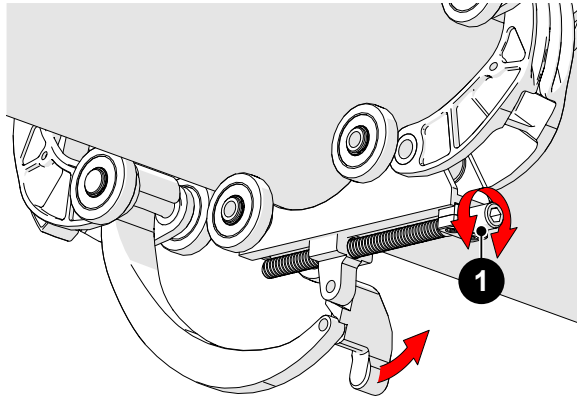

Fig. 160 - Adjust pressure of QuickLink Buckle

7. Bring the QuickLink Buckle's arm towards the opposite QuickLink. Hook the QuickLink Buckle's arm to the middle axle of the QuickLink (Fig. 159). The QuickLink Buckle adjustment knob (Fig. 160-1) may have to be loosened to allow the arm to reach the QuickLink.
8. Rotate the knob until the QuickLink Buckle's lever can be pushed down, locking the QuickLink Buckle in place (Fig. 161). The tightness of the **ROTIX** on the pipe can be adjusted using the QuickLink Buckle adjustment knob (Fig. 160-1).

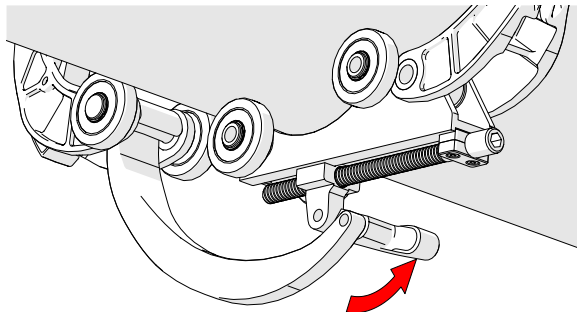

Fig. 161 - Press down to lock

9. Connect the encoder cable to the cart (Fig. 162).

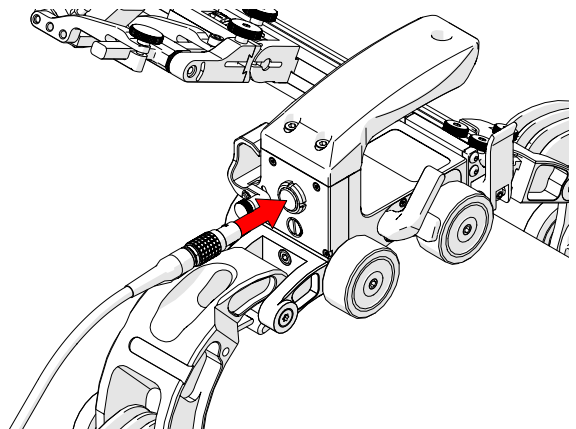

Fig. 162 - Connect encoder cable

10. Attach the cable management (Fig. 163) and route cables as required (see Cable Management System on page 35).

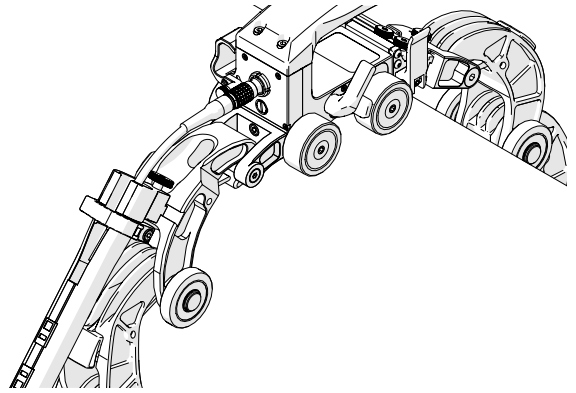

Fig. 163 - Attach cable management and route cables

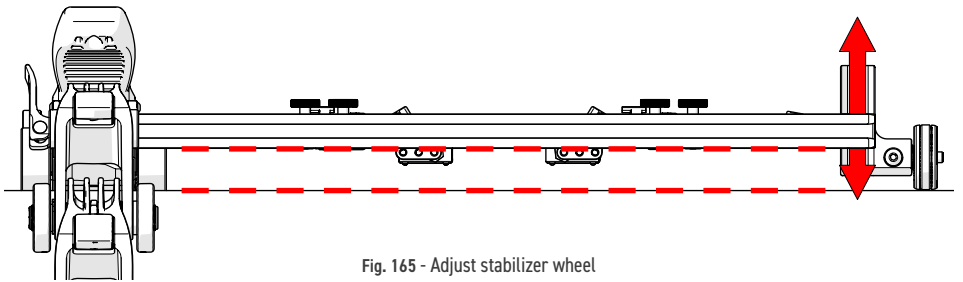

Fig. 165 - Adjust stabilizer wheel

11. Adjust the stabilizer wheel (Fig. 165) to align the frame bar parallel with the scan surface. (see Stabilizer Wheel on page 24).
12. Lower the probe holders (Fig. 164) to the scan surface (see Probe Holder Adjustment on page 31).

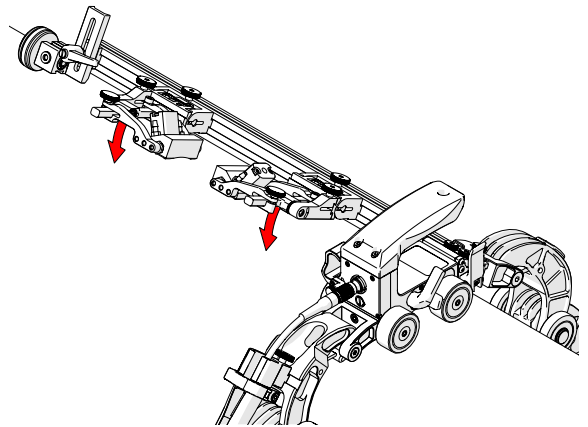

Fig. 164 - Lower probe holders

6.2. Using a Probe Positioning System (PPS)

The probe positioning system uses a linear rail with a leadscrew system to position two or four probes for weld inspection or one probe for corrosion scanning. To set up and install a probe positioning system (see *Installing a Probe Positioning System on page 26*).

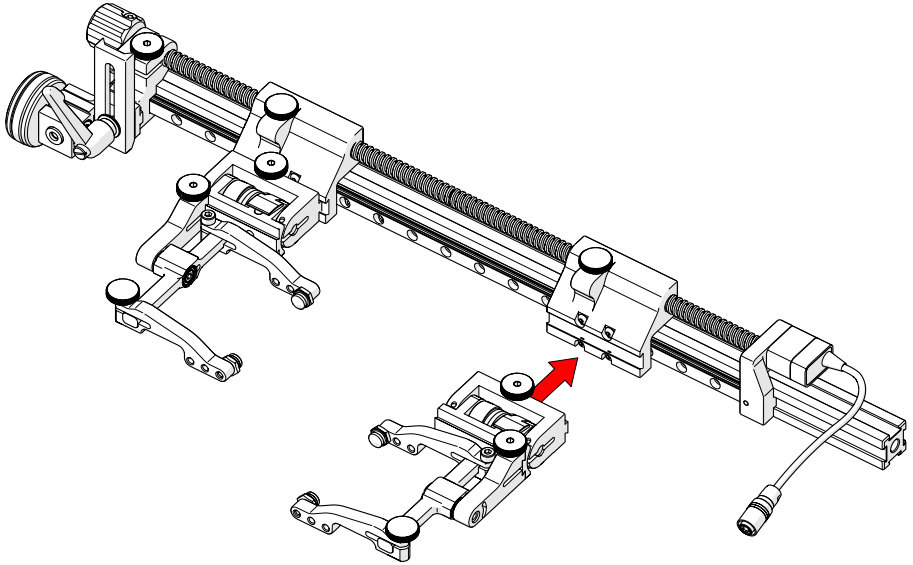

Fig. 166 - Mount probe holders

1. Attach the probe holders (see *Slip Joint Probe Holder on page 29*) to the carriage (Fig. 166).

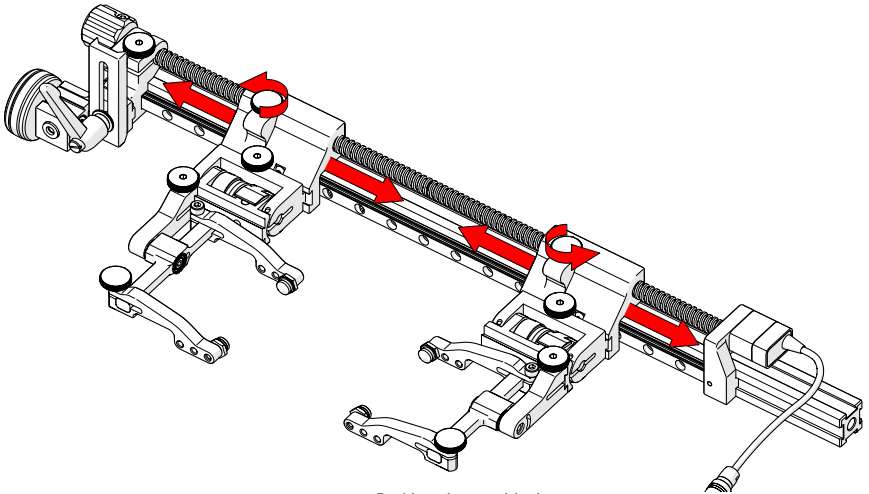

Fig. 167 - Backing plate positioning

2. The knob on the carriage allows for adjustment of the probe holders on the leadscrew (Fig. 167).

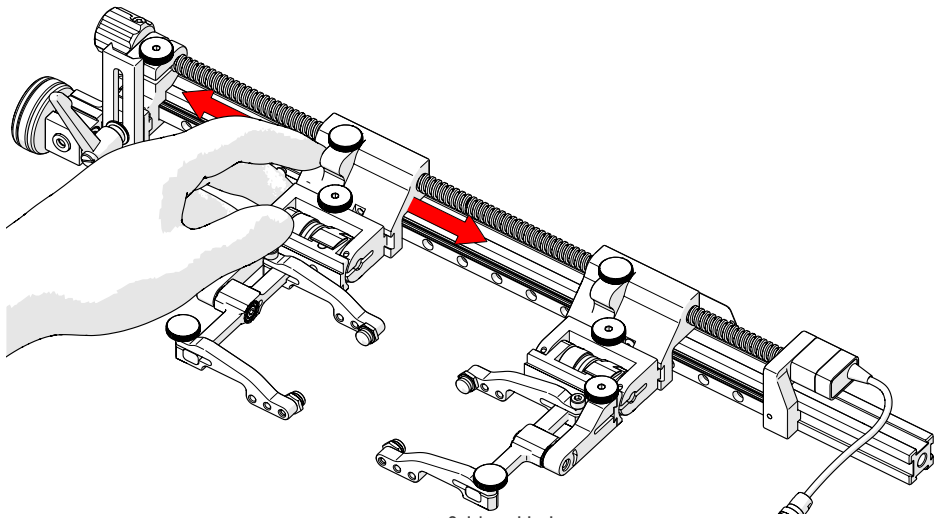

Fig. 168 - Quick positioning

3. When the knobs are loose, it is possible to push the carriages in place for quick adjustment (*Fig. 168*). Tighten both knobs to lock the carriages in position.

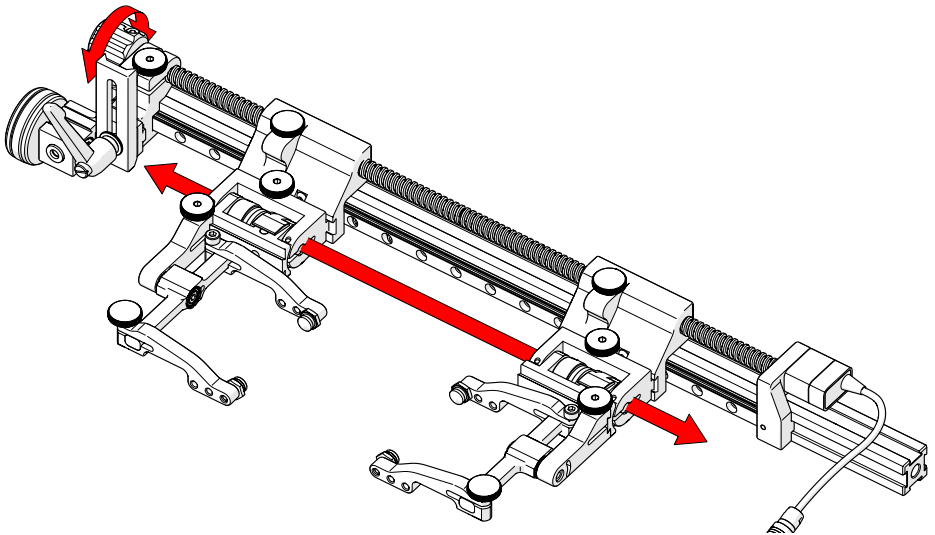

Fig. 169 - Adjustment knob

4. Ensure the PPS lock knob (*Fig. 170*) is loose. Use the PPS adjustment knob to position both carriages simultaneously (*Fig. 169*).

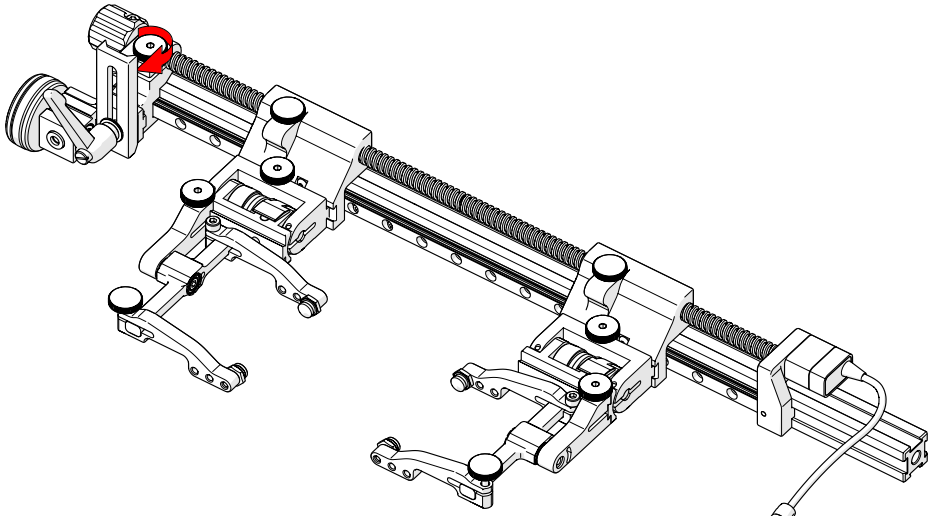

Fig. 170 - Tighten PPS lock knob

5. The PPS lock knob prevents the leadscrew from movement once scanning is underway (*Fig. 170*).

6.3. Using a Slider Probe Positioning System (Slider PPS)

The slider probe positioning system uses a slide and leadscrew system to position one or two probes for weld inspection. To setup and install a slider probe positioning system (see *Slider PPS Assembly on page 45*)

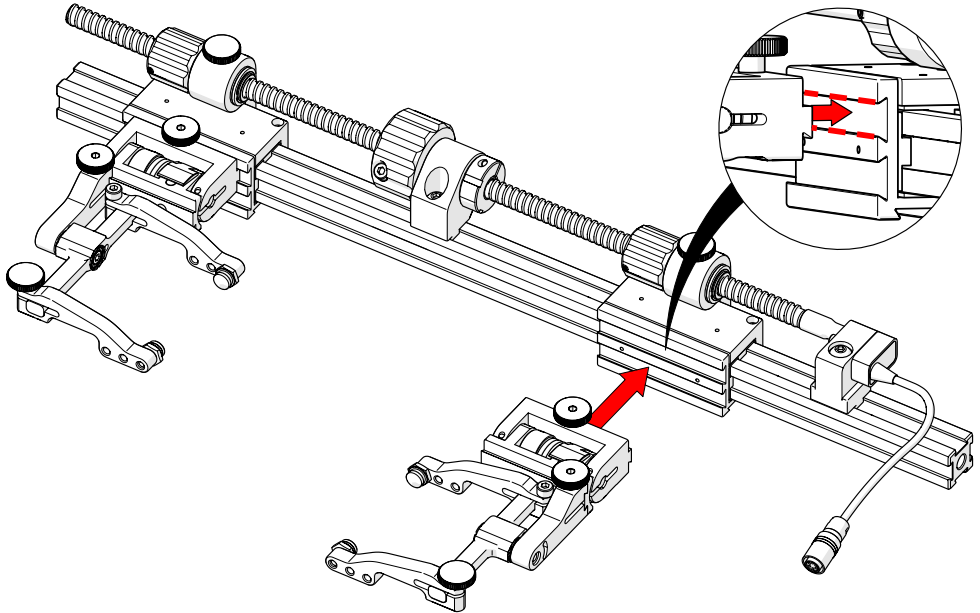

Fig. 171 - Mount probe holders

1. Attach the probe holders (see *Slip Joint Probe Holder on page 29*) to the top groove on the mounting bracket of the slider (Fig. 171).

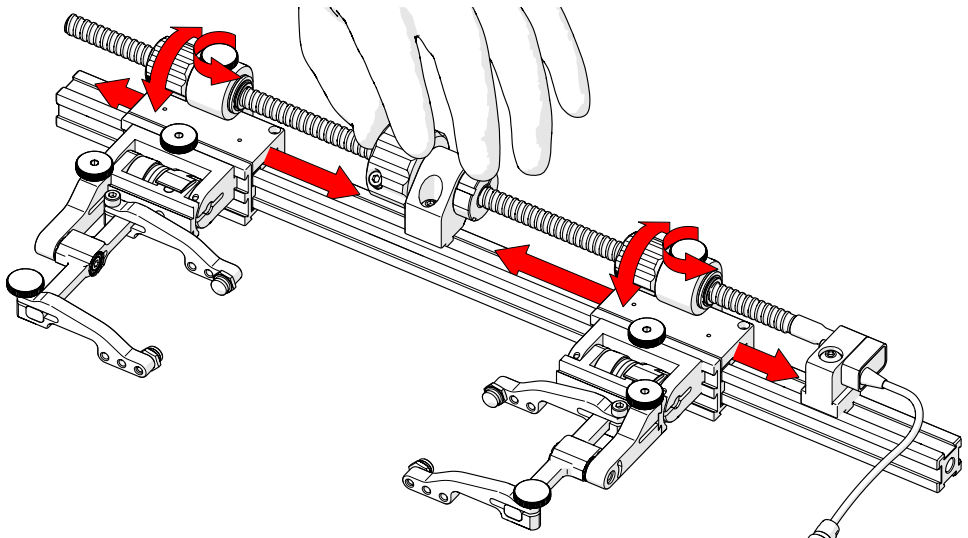

Fig. 172 - Individual slider positioning

2. Loosen the knob at the top of the slider. Rotate the small knobs allowing individual placement of the sliders (*Fig. 172*). The main knob must be held firm when rotating the small knobs to achieve the correct movement.

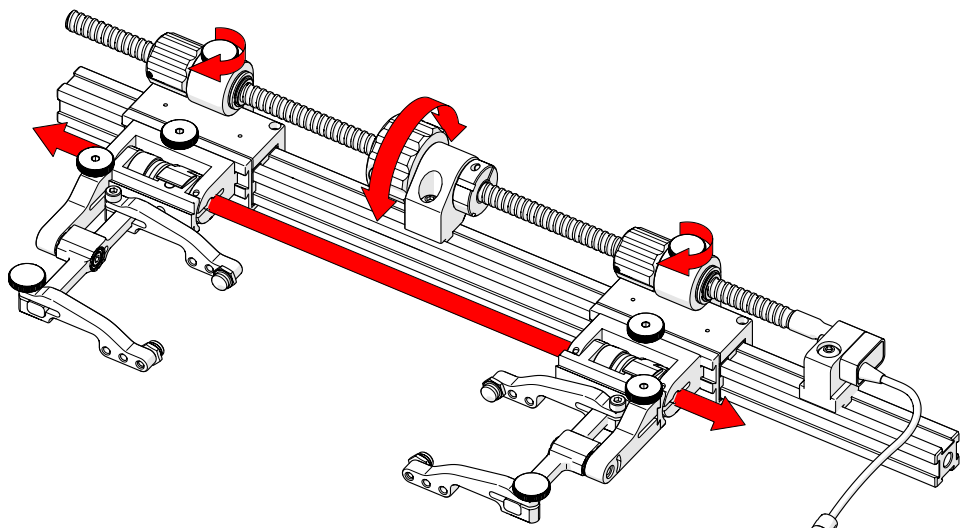

Fig. 173 - Simultaneous slider positioning

3. Ensure the slider knobs are tight and rotate the main knob to position both sliders simultaneously (*Fig. 173*).

MAINTENANCE

General cleaning of components is important to keep your system working well. All components that have no wiring or cables are completely waterproof. Components can be washed with warm water, dish soap and a medium bristle brush.

Before using the scanner, ensure all connectors are free of water and moisture.

NOTE: *All components with wiring, cables or electrical connections are splashproof. However, these components are **NOT** submersible.*

NOTE: *Never use strong solvents or abrasive materials to clean your scanner components.*

TROUBLESHOOTING

Problem	Possible Cause	Solution
The QuickLink chain is too loose/tight	Incorrect number of QuickLinks for proper scanner configuration.	Refer to the ROTIX setup chart (see <i>QuickLink Configuration Chart on page 77</i>) for the required number of QuickLinks for the diameter of the pipe/tube to be scanned. Ensure the correct outer diameter measurement of the pipe/tube. Reset the scanner with the correct number of QuickLinks.
	The QuickLink Buckle is incorrectly setup.	Adjust the tightness of the QuickLink Buckle (see <i>page 52</i>).
Insufficient probe contact.	The scanner is not set correctly.	Reconfigure the scanner as per instructions (see <i>Setup of ROTIX on Scanning Surface on page 50</i>).

8.1. Technical Support

For technical support, contact Jireh Industries (see *Jireh Industries Ltd. on page 1*).

SERVICE AND REPAIR



WARNING! DO NOT DISASSEMBLE. No user-serviceable parts. Disassembling any of the components in this product, beyond the instructions in this user manual, could void the regulatory certifications and/or effect the safety of the product.

SPARE PARTS

To order accessories or replacement parts for your ROTIX system.
(contact Jireh Industries Ltd. on page 1 for details)

NOTE: These drawings are for a parts order. This is not a list of kit contents.

10.1. ROTIX Cart

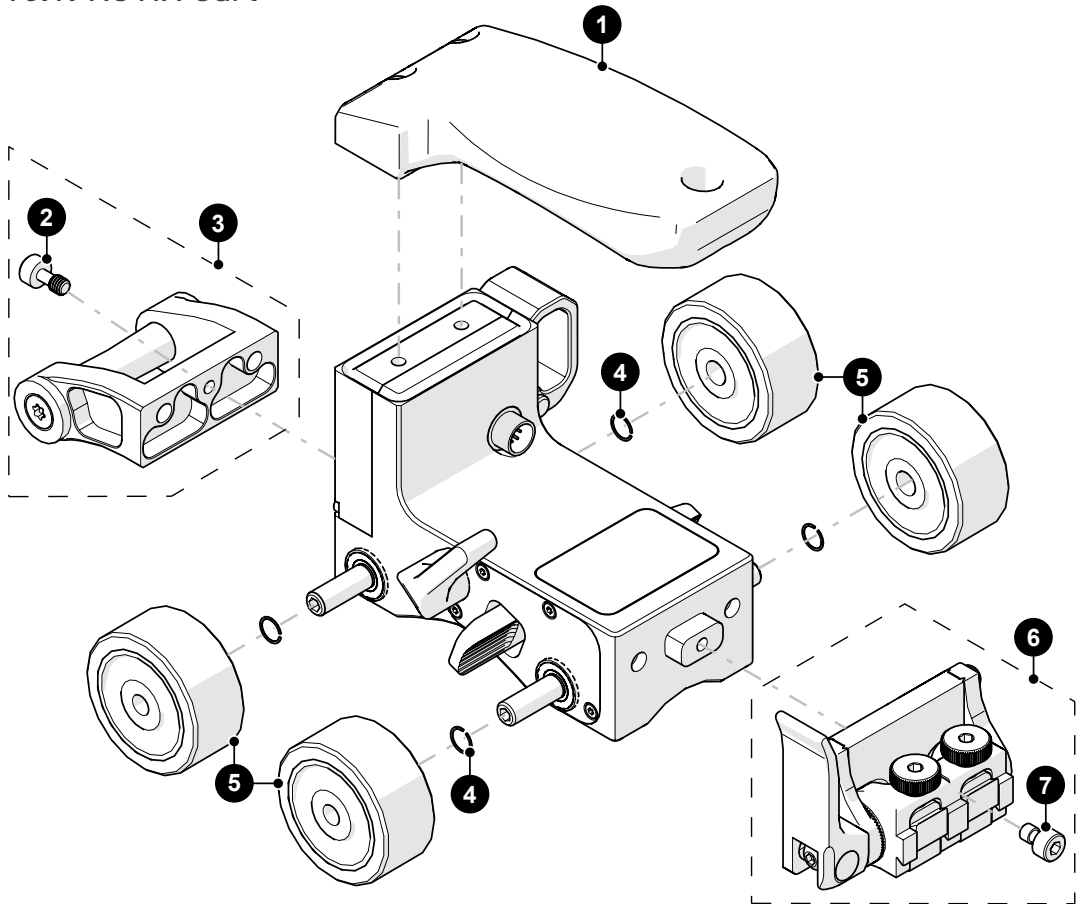

Fig. 174 - Base cart parts

BOM ID	Part #	Description
1	BTS058	MICROBE/ROTIX handle
2	MA385	COVER BOLT, M4x8 (4mm THD LENGTH) SHCS TYPE, SST
3	CES095	QuickLink tail
4	MA042	Axle retaining ring - 6mm
5	CES012	Non-magnetic wheel
6	BTS040	MICROBE/ROTIX front pivot
7	MA222	COVER BOLT, M4x6 (3mm THD LENGTH) SHCS TYPE, SST

10.2. Kit Components

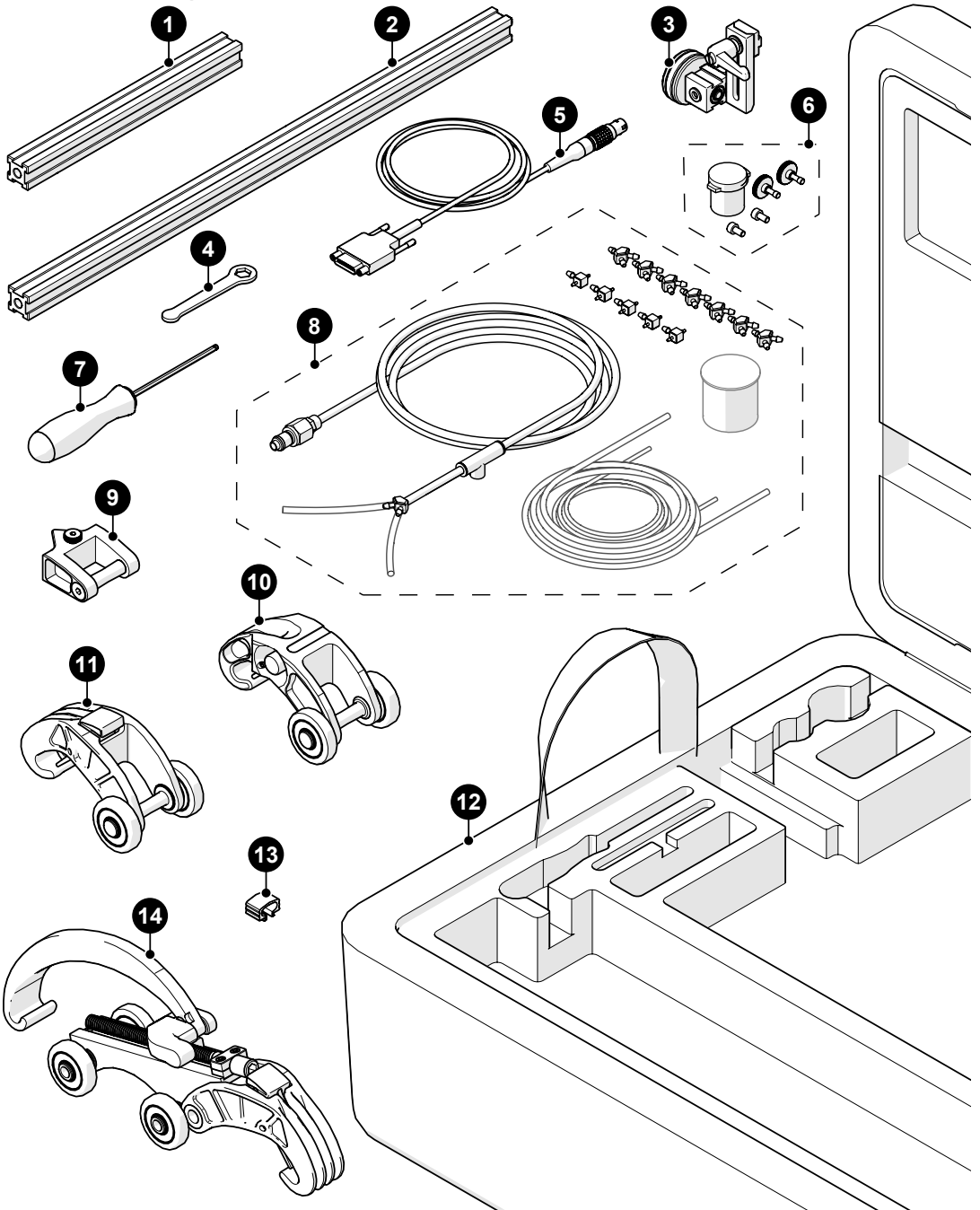

Fig. 175 - ROTIX parts

BOM ID	Part #	Description
1	BG0038-20	Frame bar, 20 cm
2	BG0038-45	Frame bar, 45 cm
3	BTS049	Stabilizer wheel (<i>see Stabilizer Wheel</i>)
4	EA470	10 mm (<i>3/8 in</i>) wrench
5	UMA026-X	J100 encoder cable (<i>see Encoder Connector Type</i>)
6	PHG014	2 probe spare parts kit
7	EA414	Hex driver, 3 mm (<i>0.118 in</i>)
8	CMG007	Irrigation kit, 2-4 probe
9	CES096	QuickLink mounting bracket
10	EES011	Dovetail QuickLink
11	EES004	QuickLink
12	CEA036	ROTIX case
13	BG0091	Cable clip
14	EES014	QuickLink buckle

10.2.1. Encoder Connector Type

Connector Type	Company/Instrument	Connector Type	Company/Instrument
B	Olympus OmniScan MX Zetec Topaz	G	Sonotron Isonic 25xx
C	Olympus Focus LT Zetec Z-Scan Eddyfi Ectane 2	U	Sonatest Veo / Prisma
E	Olympus OmniScan SX/MX2/X3 M2M MANTIS/GEKKO LEMO	V	Pragma PAUT
F	TD (<i>Technology Design</i>)	AD	Sonatest Veo / Prisma - Single Axis

NOTE: Additional encoder connector styles are available.
(contact Jireh Industries Ltd. on page 1 for details)

10.2.2. Stabilizer Wheel

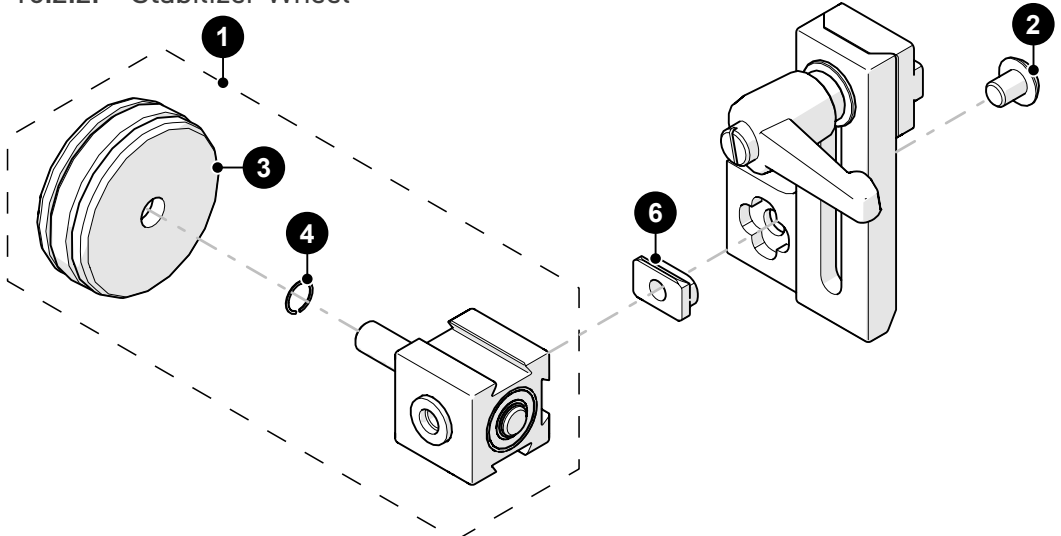
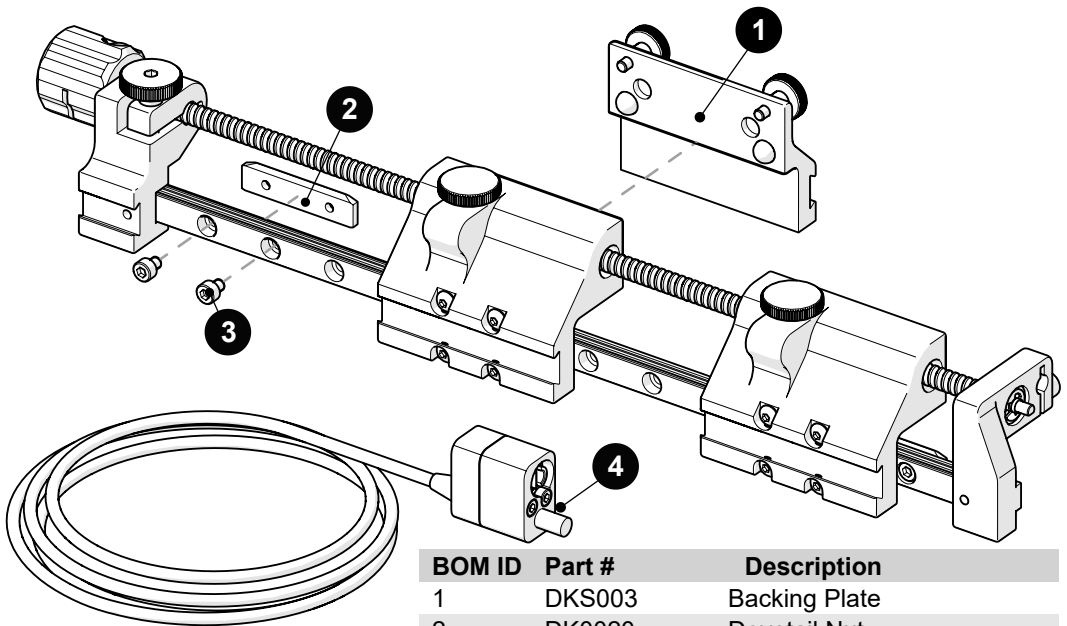

Fig. 176 - Stabilizer wheel

BOM ID	Part #	Description
1	BGS008	Magnetic Wheel Block
2	MD074-006	BHCS, M5x0.8 X 6mm, SST
3	BTS031	Magnetic wheel
4	MA042	Axle retaining ring - 6mm

10.3. Probe Positioning

10.3.1. Probe Positioning System (PPS)



BOM ID	Part #	Description
1	DKS003	Backing Plate
2	DK0020	Dovetail Nut
3	MD049-004	SHCS, M3x0.5 X 4 mm, SST
4	DKS009-S-0.3	PPS Encoder

Fig. 177 - Probe positioning system parts

NOTE: Additional PPS lengths are available.
(contact Jireh Industries Ltd. on page 1 for details)

NOTE: Additional leadscrew lengths are available.
(contact Jireh Industries Ltd. on page 1 for details)

10.3.2. Slider Probe Positioning System (Slider PPS)

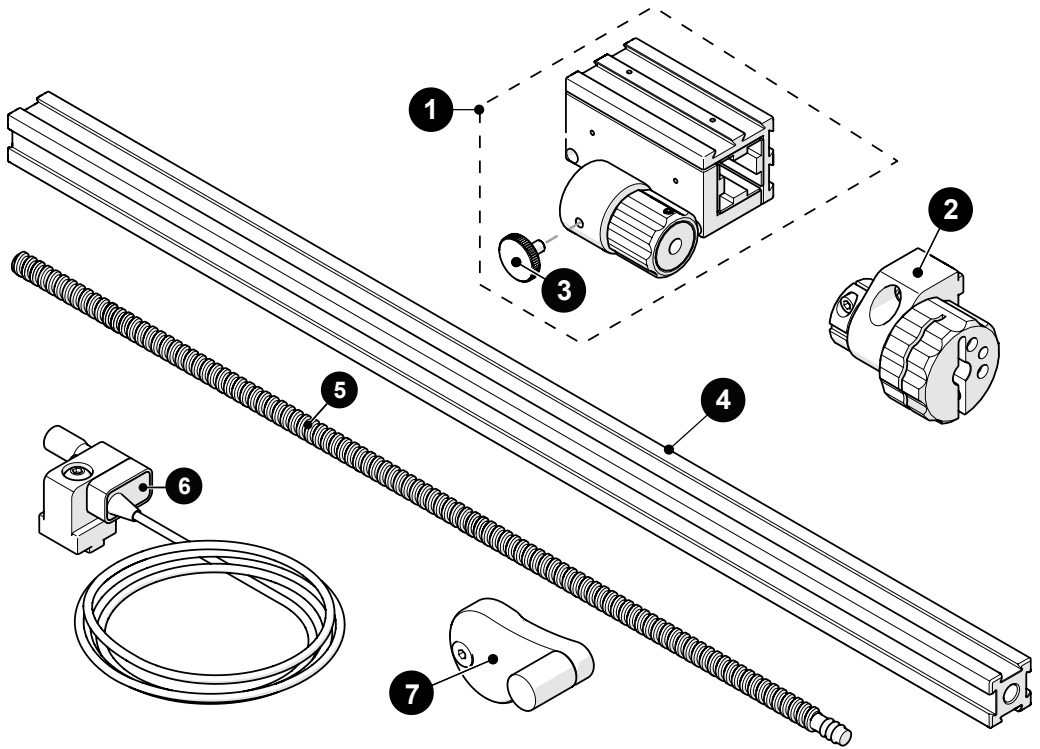

BOM ID	Part #	Description
1	CJS008	Slider PPS Slider
2	CJS001	Slider PPS Main Knob
3	EA212	Knurled Knob, M4 x 0.7 x 8 mm, SST
4	BG0038-X	Frame Bar (see Frame Bars)
5	<i>See Slider PPS Encoded Leadscrew</i>	
6	CJS017-S-0.3	Slider PPS Encoder
7	CJS016	Crank Handle

Fig. 178 - Slider probe positioning system parts

10.3.3. Slider PPS Encoded Leadscrew

Part #	Length	Part #	Length
CJS009-16	16 cm (6.3 in)	CJS009-21	21 cm (8.3 in)
CJS009-23	23 cm (9.1 in)	CJS009-28	28 cm (11 in)
CJS009-33	33 cm (13 in)	CJS009-38	38 cm (15 in)
CJS009-43	43 cm (16.9 in)	CJS009-48	48 cm (18.9 in)

Fig. 179 - Slider PPS encoded leadscrew selection

10.4. Probe Holders

10.4.1. Slip Joint Probe Holder Parts

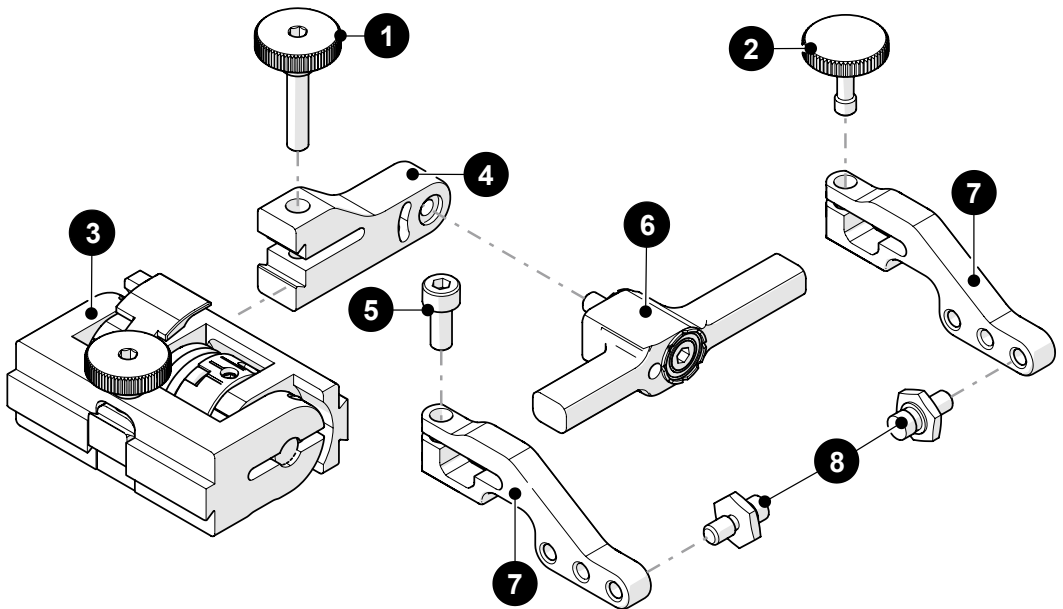

BOM ID	Part #	Description
1	PH0104	Knurled Knob, M4 x 0.7 x 18 mm, 4 mm stand off, SST
2	PH0082	Knurled Knob, M4 x 0.7 x 10 mm, 3 mm stand off, SST
3	PHS022	Slip Joint Probe Holder Subassembly
4		<i>see Swing Arm Style</i>
5	MD050-010	SHCS, M4 x 0.7 x 10 mm, SST
6		<i>see Yoke Style</i>
7		<i>see Arm Style</i>
8	PH0011-X	Pivot Button Style (<i>see Pivot Button Style</i>)

Fig. 180 - Slip joint probe holder parts

10.4.2. Vertical Probe Holder Parts

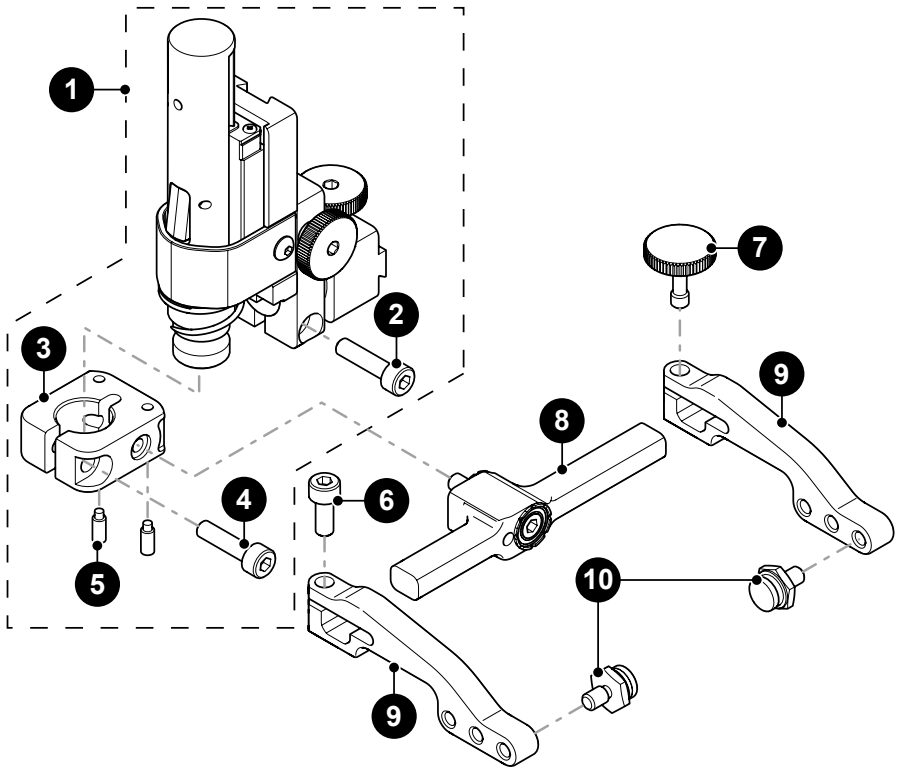

BOM ID	Part #	Description
1	PHS028	Vertical Probe Holder Subassembly
2	MA307	Screw, M4x16 mm High Strength SST SHCS
3	PH0087	Vertical Probe Holder Base
4	MD050-016	SHCS, M4 x 0.7 x 16 mm, SST
5	MA096	Screw, M3x8 mm Dog Point Set, SST
6	MD050-010	SHCS, M4 x 0.7 x 10 mm, SST
7	PH0082	Knurled Knob, M4 x 0.7 x 10 mm, 3 mm stand off, SST
8	<i>see Yoke Style</i>	
9	<i>see Arm Style</i>	
10	PH0011-X	Pivot Button Style (<i>see Pivot Button Style</i>)

Fig. 181 - Vertical probe holder

10.5. Probe Holder Components

10.5.1. Arm Style











Arm Style	Part #		Arm Style	Part #	
A Standard, Flat	PH0090		B Short, Flat	PH0089	
C Long, Flat	PH0099		D Standard, Drop	PH0093	
E Short, Drop	PH0092		F Long, Drop	PH0094	
G Standard, Extra-Drop	PH0096		H Short, Extra-Drop	PH0095	
I Extra-Short, Flat	PH0159		J Extra-Short, Drop	PH0161	

Fig. 182 - Probe holder arm selection

10.5.2. Yoke Style

Yoke Style	Part #	Length		Yoke Style	Part #	Length	
S Standard	PHS052	6.3 cm (2.47 in)		W Wide	PHS063	7.9 cm (3.06 in)	

Fig. 183 - Probe holder yoke selection

10.5.3. Swing Arm Style

Swing Arm Style	Part #	Length		Swing Arm Style	Part #	Length	
Short	PH0069	4.1 cm (1.61 in)		Long	PH0100	4.6 cm (1.81 in)	

Fig. 184 - Swing arm selection

NOTE: Short swing arm only compatible with standard yoke style.

10.5.4. Pivot Button Style









Pivot Hole Size	Wedge Type		Pivot Hole Size	Wedge Type	
01 8.0 mm (0.315 in)	Olympus PA		02 5.0 mm (0.197 in)	Olympus TOFD	
03 2.7 mm (0.106 in)	Sonatest DAAH PA		04 9.5 mm (0.375 in)	-	
06 3.0 mm (0.118 in)	-		07 2.3 mm (0.09 in)	-	
08 Conical Head	-		09 5 mm (0.197 in) Internal	Zetec PA/TOFD	

Fig. 185 - Pivot button selection

NOTE: Additional probe holder pivot button types are available. (contact Jireh Industries Ltd. on page 1 for details)

10.6. Variable Components

10.6.1. Frame Bars











Part #	Length		Part #	Length	
BG0038-05	5 cm (1.97 in)		BG0038-10	10 cm (3.94 in)	
BG0038-15	15 cm (5.91 in)		BG0038-20	20 cm (7.87 in)	
BG0038-25	25 cm (9.84 in)		BG0038-30	30 cm (11.81 in)	
BG0038-35	35 cm (13.78 in)		BG0038-40	40 cm (15.75 in)	
BG0038-45	45 cm (17.72 in)		BG0038-50	50 cm (19.69 in)	
BG0038-55	55 cm (21.65 in)				

Fig. 186 - Frame bar selection

10.7. Accessories

10.7.1. Cable Management

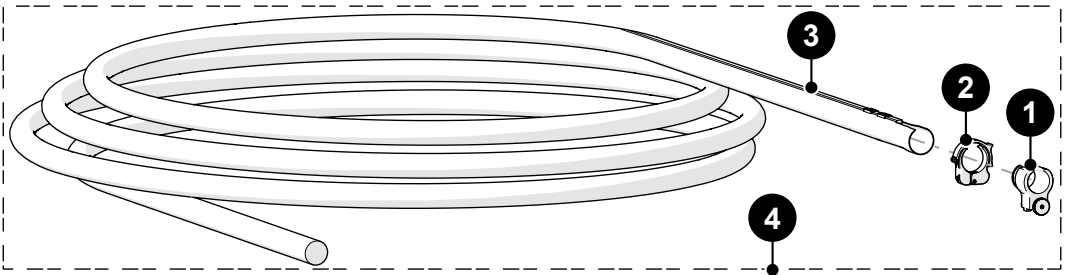

BOM ID	Part #	Description
1	CES067	Cable Management Mount, Dovetail Mount
2	CES066	Cable Management Clamp, Dovetail Mount
3	<i>See Cable Management Sleeving</i>	
4	CES044-	Cable Management: Dovetail (<i>see cable management sleeving</i>)

Fig. 187 - Cable management

10.7.1.1 Cable Management Sleeving

Part #	Length
CX0141	4.5 m (14.7 ft)
CX0145	9.5 m (31.2 ft)

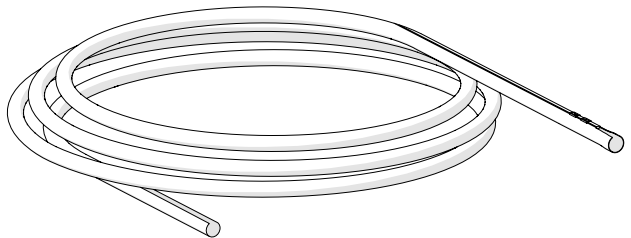

Fig. 188 - Cable management sleeving

10.7.2. Preamp Bracket

Part #	Description
CES029	Preamp Bracket
CES029-V	Preamp Bracket with Velcro

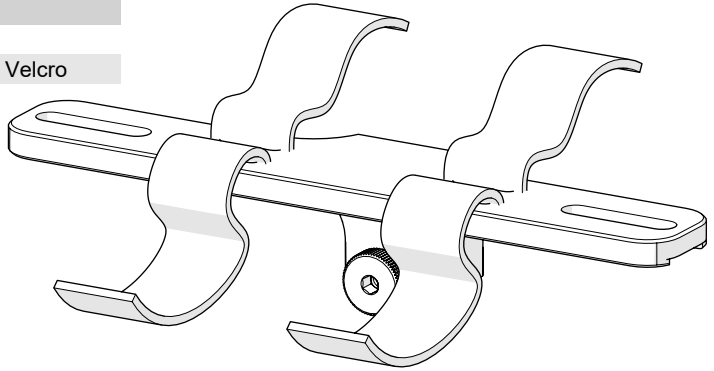

Fig. 189 - Preamp bracket

10.7.3. Magnetic Wheel Kit

Part #	Description
BTG014	Magnetic Wheel Kit

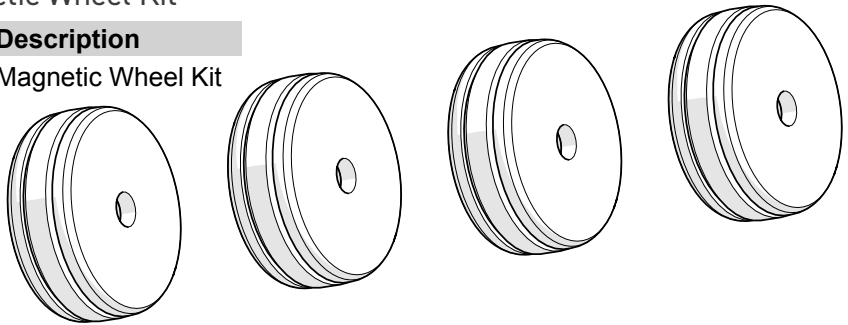
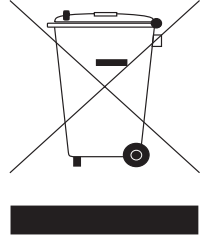

Fig. 190 - Magnetic wheel kit

DISPOSAL

WEEE Directive

In accordance with European Directive on Waste Electrical and Electronic Equipment (WEEE), this symbol indicates that the product must not be disposed of as unsorted municipal waste, but should be collected separately. Refer to Jireh Industries for return and/or collection systems available in your country.



LIMITED WARRANTY

WARRANTY COVERAGE

Jireh Industries warranty obligations are limited to the terms set forth below: Jireh Industries Ltd. (“Jireh”) warrants this hardware product against defects in materials and workmanship for a period of THREE (3) YEARS from the original date of purchase. If a defect exists, at its option Jireh will (1) repair the product at no charge, using new or refurbished replacement parts, (2) exchange the product with a product that is new or which has been manufactured from new or serviceable used parts and is at least functionally equivalent to the original product, or (3) refund the purchase price of the product. A replacement product/part assumes the remaining warranty of the original product or ninety (90) days from the date of replacement or repair, whichever provides longer coverage for you. When a product or part is exchanged, any replacement item becomes your property and the replaced item becomes Jireh’s property. When a refund is given, your product becomes Jireh’s property.

OBTAINING WARRANTY SERVICE

To utilize Jireh’s warranty service you must ship the product, at your expense, to and from Jireh Industries. Before you deliver your product for warranty service you must phone Jireh and obtain an RMA number. This number will be used to process and track your product. Jireh is not responsible for any damage incurred during transit.

EXCLUSIONS AND LIMITATIONS

This Limited Warranty applies only to hardware products manufactured by or for Jireh Industries. This warranty does not apply: (a) to damage caused by accident, abuse, misuse, misapplication, or non-Jireh products; (b) to damage caused by service (including upgrades and expansions) performed by anyone who is not a Jireh Authorized Service Provider; (c) to a product or a part that has been modified without the written permission of Jireh.

Jireh Industries Ltd.
53158 Range Rd 224
Ardrossan AB T8E 2K4
Canada
780-922-4534
jireh.com

All brands are trademarks or registered trademarks of their respective owners and third-party entities.

Changes or modifications to this unit or accessories not expressly approved by the party responsible for compliance could void the user's authority to operate the equipment.

All specifications are subject to change without notice.

Printed in Canada

© 2023 Jireh Industries Ltd.

APPENDIX

13.1. QuickLink Configuration Chart

PIPE OD RANGE					
MIN (in)	MAX (in)	MIN (mm)	MAX (mm)	QUICKLINKS	DOVETAIL QUICKLINK EES011
3.0	4.6	76	117	0	0
4.4	5.7	112	145	0	
5.6	6.9	142	175	1	
6.8	8.0	173	203	2	
7.9	9.2	201	234	3	
9.0	10.3	229	262	4	
10.2	11.4	259	290	5	
11.2	12.5	284	318	6	
12.4	13.6	315	345	7	
13.4	14.7	340	373	8	
14.5	15.8	368	401	9	
15.6	16.9	396	429	10	
16.7	18.0	424	457	11	
17.8	19.1	452	485	12	
18.8	20.1	478	511	13	
19.9	21.2	505	538	14	
21.0	22.3	533	566	15	1
22.1	23.4	561	594	16	
23.2	24.5	589	622	17	
24.2	25.6	615	650	18	
25.3	26.6	643	676	19	
26.4	27.7	671	704	20	
27.5	28.8	699	732	21	
28.5	29.9	724	759	22	
29.6	30.9	752	785	23	
30.7	32.0	780	813	24	
31.8	33.1	808	841	25	
32.8	34.2	833	869	26	
33.9	35.3	861	897	27	
35.0	36.3	889	922	28	
36.7	37.4	932	950	29	
37.1	38.5	942	978	30	

CE0198 Rev 00.1



Jireh Industries Ltd.
53158 Range Road 224
Ardrossan, Alberta
Canada
T8E 2K4

780-922-4534

jireh.com