



 **ROTIX**

CE0203 Rev 00.3

Reduced Width Chain Scanner

SAFETY WARNINGS / PRECAUTIONS

KEEP THIS MANUAL – DO NOT LOSE

THIS MANUAL IS PART OF THE **ROTIX** AND MUST BE RETAINED FOR THE LIFE OF THE PRODUCT. PASS ON TO SUBSEQUENT OWNERS.

Ensure any amendments are incorporated with this document.



CAUTION! The **ROTIX** is designed for a specific use. Using the **ROTIX** outside of its intended use could cause damage to the product. Read and understand this manual before using.



WARNING! DO NOT DISASSEMBLE. No user-serviceable parts. Disassembling any of the components in this product, beyond the instructions in this user manual, could void the regulatory certifications and/or effect the safety of the product.



The **WEEE** symbol indicates that the product must not be disposed of as unsorted municipal waste, but should be collected separately.

(see *Disposal* on page 42 for additional details).

TABLE OF CONTENTS

1	Identification	1
	1.1. Product Information.....	1
	1.2. Manufacturer	1
2	Product Specifications	2
	2.1. Intended use	2
	2.1.1. Operating Limits	2
	2.1.2. Operating environment	2
	2.2. Dimensions and Weight	2
	2.3. Environmental Sealing	4
	2.4. Performance Specifications	4
3	Definitions	5
	3.1. Definition of symbols	5
	3.2. Definitions of Terms	5
4	System Components	6
	4.1. Base System Components	6
	4.1.1. Reduced Width ROTIX Link	6
	4.1.2. Frame Bar	6
	4.1.3. Vertical Probe Holder	6
	4.1.4. QuickLink Components	7
	4.1.4.1 QuickLink	7
	4.1.4.2 Dovetail QuickLink	7
	4.1.4.3 QuickLink Buckle	7
	4.1.4.4 QuickLink Mounting Bracket	8
	4.1.5. Irrigation Kit	8
	4.1.6. Tools	8
	4.1.7. Case	8
	4.2. Compatible Components	9
	4.2.1. Frame Bar	9

4.2.2.	Encoder Adapter	9
4.2.3.	Preamp Bracket	9
4.3.	Tools	10
4.3.1.	Included tools	10
4.3.2.	Optional tools	10

5 Preparation For Use 11

5.1.	Configurations	11
5.1.1.	Single Probe Scanning	11
5.1.2.	Two Probe Scanning.....	11
5.2.	Reduced Width Link Setup And Adjustment	12
5.2.1.	Attach a Frame Bar	12
5.2.2.	Wheel Removal/Installation	13
5.2.3.	QuickLink Tail	13
5.3.	Connecting QuickLinks & Dovetail Links	14
5.3.1.	Connecting QuickLinks	14
5.3.2.	Disconnecting QuickLinks	14
5.3.3.	Disconnecting the Dovetail QuickLink	15
5.4.	Vertical Probe Holder	16
5.4.1.	Probe Holder Setup.....	16
5.4.2.	Probe Holder Vertical Adjustment	17
5.4.3.	Probe Holder Transverse Adjustment	18
5.4.4.	Probe Holder Longitudinal Adjustment	19
5.4.5.	Probe Holder Left/Right Conversion	20
5.5.	Pivot Buttons	22
5.6.	Cable Management System	22
5.6.1.	Cable Management Dovetail Mount	23
5.6.2.	Cable Management Setup	23
5.6.3.	Clamp Setup	24
5.7.	Magnetic Wheel Kit	25
5.8.	Preamp Bracket	26
5.8.1.	Mounting Preamp Bracket	26
5.8.2.	Attaching Preamp with Screws	26
5.8.3.	Attaching Preamp with Velcro Straps	27

6 Operation 28

6.1.	Setup of ROTIX on a Scanning Surface	28
------	--	----

7 Maintenance 32

8	Troubleshooting	33
	8.1. Technical Support	33
9	Service and Repair	34
10	Spare Parts	35
	10.1. Kit Components	35
	10.1.1. Encoder Connector Type	36
	10.2. Accessories	37
	10.2.1. Cable Management	37
	10.2.1.1 Cable Management Sleeving	37
	10.2.2. Preamp Bracket	37
	10.2.3. Magnetic Wheel Kit	38
	10.3. Vertical Probe Holder Parts	39
	10.4. Probe Holder Components	40
	10.4.1. Arm Style	40
	10.4.2. Yoke Style	40
	10.4.3. Pivot Button Style	40
	10.5. Variable Components	40
	10.5.1. Frame Bars	40
	10.6. Case	41
11	Disposal	42
12	Limited Warranty	43
13	Appendix	45
	13.1. Reduced Width Chain Configuration Setup Chart	45

IDENTIFICATION

1.1. Product Information

The manually operated **ROTIX** reduced width chain scanner provides encoded probe positions of one or two probes while requiring a minimal footprint.

1.2. Manufacturer

Distributor:

Manufacturer:

Jireh Industries Ltd.
53158 Range Road 224
Ardrossan, Alberta, Canada
T8E 2K4
780.922.4534
jireh.com

PRODUCT SPECIFICATIONS

2.1. Intended use

The scanner's primary purpose is to move an inspection tool over a cylindrical surface for the inspection of pipes and vessels.

2.1.1. Operating Limits

Category	Parameter	Specification
Inspection Surface	Minimum OD, external circumferential pipe/tube range	10.2 cm (4 in)
	Maximum OD, external circumferential pipe/tube range	96.5 cm (38 in)
Scanner	Radial Clearance	9 cm (3.5 in)

2.1.2. Operating environment

The ROTIX chain scanner is designed for use in an industrial environment that is between -20°C and 50°C (-4°F and 122°F).

2.2. Dimensions and Weight

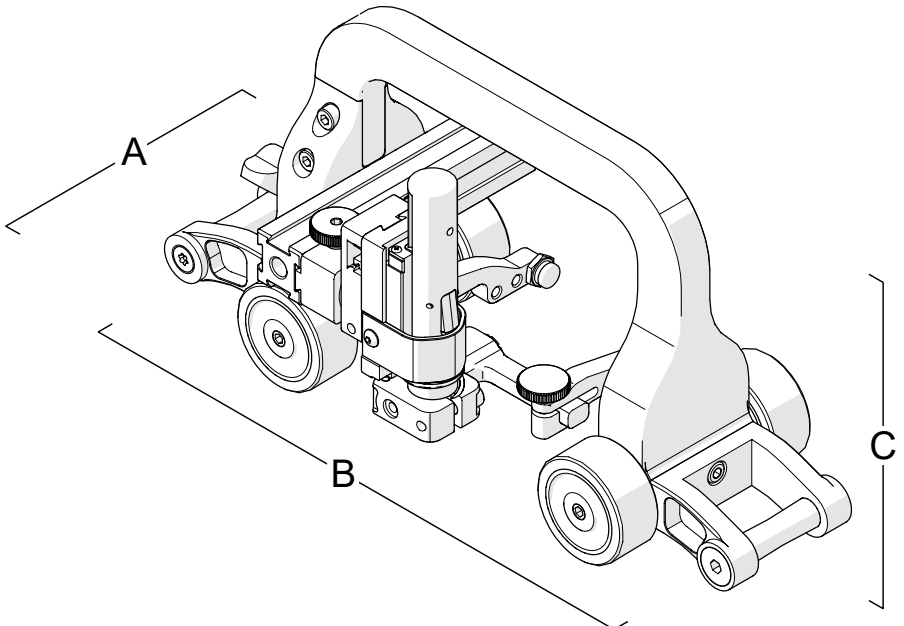

Fig. 1 - Single probe dimensions

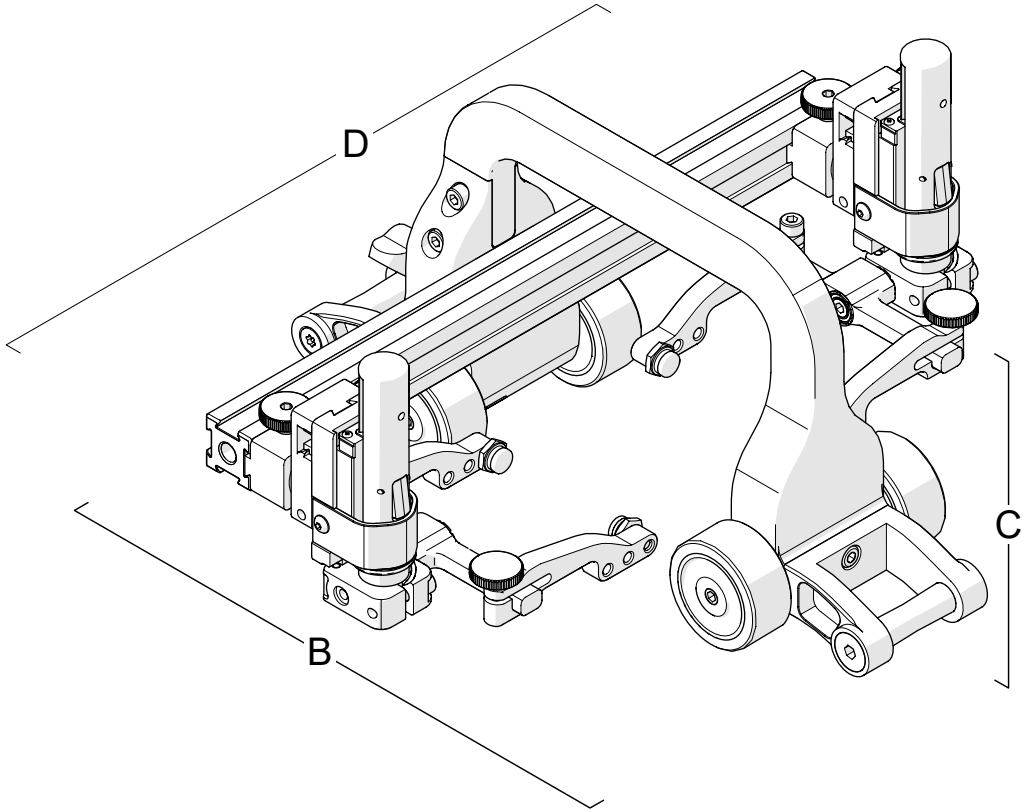

Fig. 2 - Two probe dimensions

A: Link width	10 cm	(3.9 in)
B: Link depth	24.1 cm	(9.5 in)
C: Link height	12 cm	(4.7 in)
D: Link width	25 cm	(9.8 in)
Link Weight*	0.64 kg	(1.4 lb)
Encoder Cable Length**	5 m	(16.4 ft)

* Link weight does not include cabling, frame bar or probe holder(s).

** Custom encoder cable lengths available.

2.3. Environmental Sealing

Watertight (*submersible*) (*contact Jireh Industries Ltd. on page 1 for additional details*).

2.4. Performance Specifications

Category	Specification
X-Axis encoder resolution	16.3 counts/mm (<i>414.5 counts/inch</i>)

DEFINITIONS

3.1. Definition of symbols



Instructions to 'look here' or to 'see this part.'

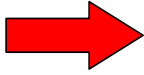

Denotes movement. Instructing the user to carry out an action in a specified direction.

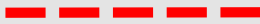

Indicates alignment axis, can also indicate insertion or movement of parts.



Alerts user that the view has changed to a reverse angle.

3.2. Definitions of Terms

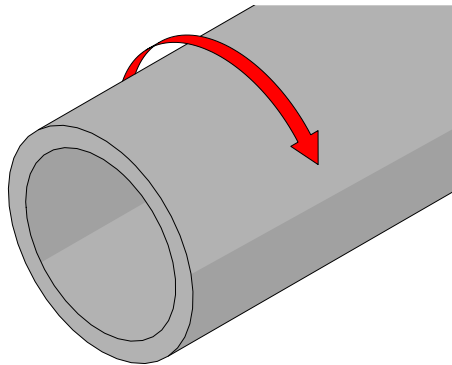

Fig. 3 - Circumferential scanning

Circumferential

Direction of scan travel is around the circumference of the pipe/tube (Fig. 3).

SYSTEM COMPONENTS

4.1. Base System Components

4.1.1. Reduced Width ROTIX Link CES104-

This link reduces the scanner footprint requiring less insulation or coating to be removed from the pipe. Mount one or two probes and track positional information with the built-in encoder (*Fig. 4*).

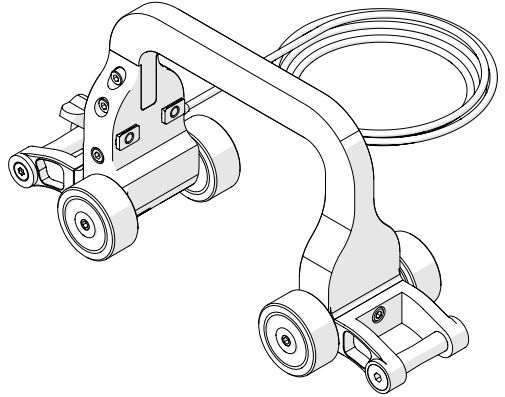

Fig. 4 - Reduced width ROTIX link

4.1.2. Frame Bar BG0038-

Frame bars provide a mount probe holders, probe positioning systems and other accessories.

Frame bars are available in a variety of lengths (*Fig. 5*).

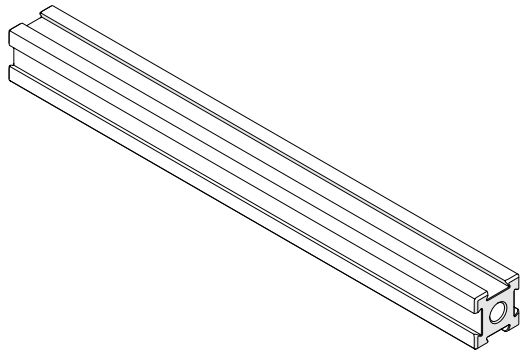

Fig. 5 - Frame bar

4.1.3. Vertical Probe Holder PHA015-

The vertical probe holder is designed to carry many different types of probes and wedges. Available with various types of yokes, arms and pivot buttons. The vertical probe holder features different adjustment options for each unique probe/wedge setup (*Fig. 6*).

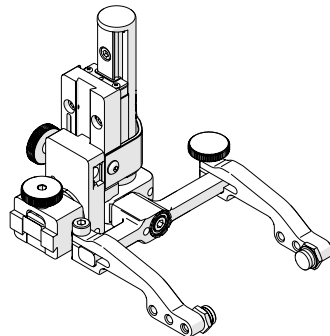

Fig. 6 - Vertical probe holder

4.1.4. QuickLink Components

The QuickLink components fasten a **ROTIX** system circumferentially around a pipe or tube.

4.1.4.1 QuickLink EES004

QuickLinks connect to assemble the required length to mount the system on a pipe (Fig. 7).

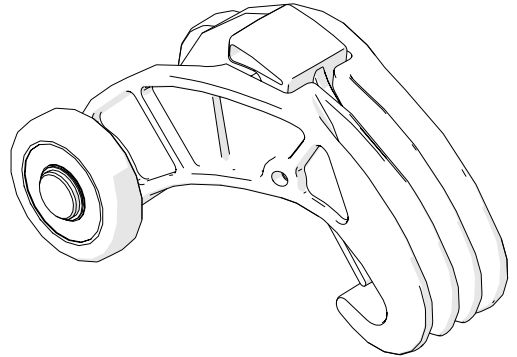

Fig. 7 - QuickLink

4.1.4.2 Dovetail QuickLink EES019

The Dovetail QuickLink connects to QuickLinks, providing a mounting point for accessories such as cable management (Fig. 8).

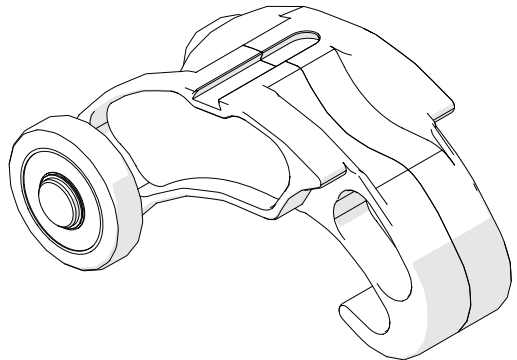

Fig. 8 - Dovetail QuickLink

4.1.4.3 QuickLink Buckle EES014

The QuickLink Buckle enables adjustment of the chain tension and provides the connection point of the QuickLinks assembly (Fig. 9).

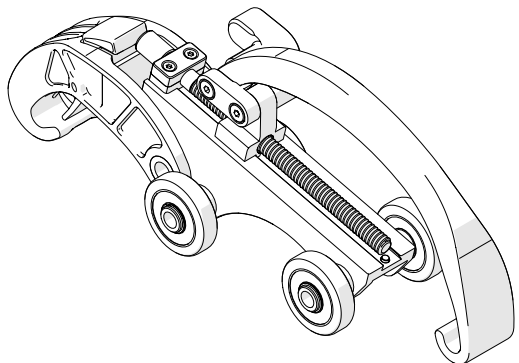

Fig. 9 - QuickLink Buckle

4.1.4.4 QuickLink Mounting Bracket CES096

The QuickLink Mounting Bracket attaches to a frame bar and provides a connection point for QuickLinks (Fig. 10).

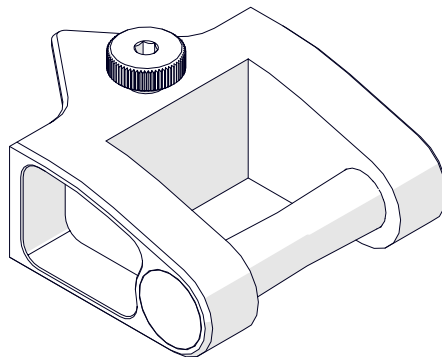

Fig. 10 - QuickLink Mounting Bracket

4.1.5. Irrigation Kit CMG007

The irrigation kit provides a variety of hoses, fittings, connectors, and splitters commonly used during non-destructive inspection (Fig. 11).

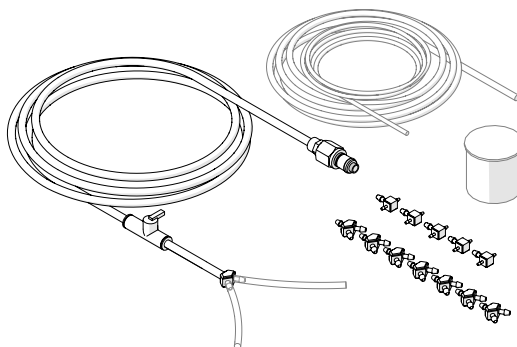

Fig. 11 - Irrigation kit

4.1.6. Tools

Several tools are included for various scanner and accessory adjustments. (see *Tools on page 8*)

4.1.7. Case

The system is provided with a rugged carrying case.

4.2. Compatible Components

4.2.1. Frame Bar BG0038-

Frame bars are used to mount probe holders, probe positioning systems and other accessories.

Frame bars are available in a variety of lengths (*Fig. 12*).

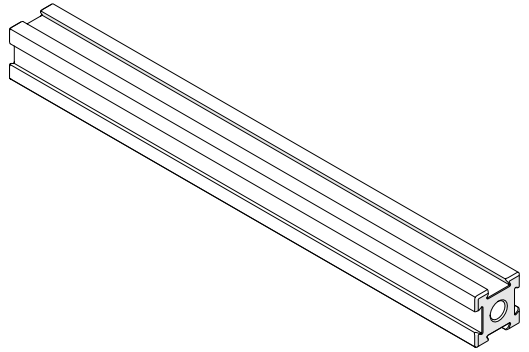

Fig. 12 - Frame bar

4.2.2. Encoder Adapter UMA010-

Adapt a scanner's existing encoder connector to a different encoder style (*Fig. 13*).

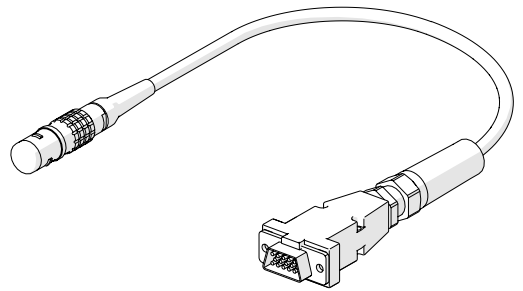

Fig. 13 - Encoder adapter

4.2.3. Preamp Bracket CES029-

A bracket that mounts to a scanner to hold various preamps (*Fig. 14*).

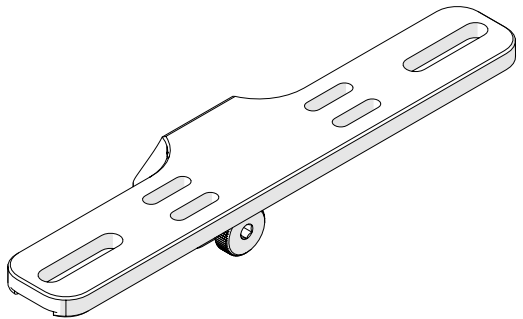

Fig. 14 - Preamp bracket

4.3. Tools

4.3.1. Included tools

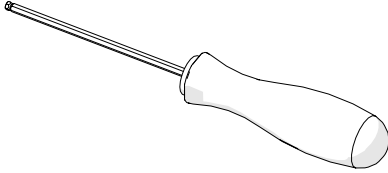

Fig. 15 - 3 mm hex driver

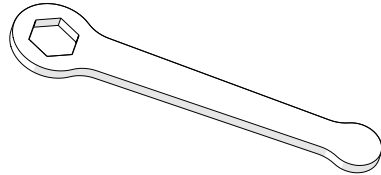

Fig. 16 - 3/8 in wrench

The 3 mm hex driver (*Fig. 15*) is sufficient for all typical operations and adjustments of the **ROTIX**. The 3/8 in wrench (*Fig. 16*) removes and installs pivot buttons on the probe holders.

4.3.2. Optional tools

Some specialized adjustments require tools that are not included in this kit.

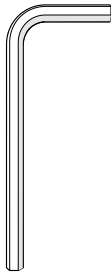

Fig. 17 - 1.5 mm hex wrench

PREPARATION FOR USE

5.1. Configurations

5.1.1. Single Probe Scanning

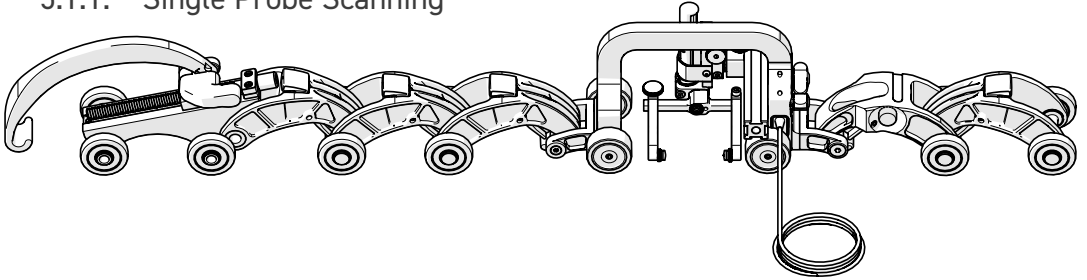

Fig. 18 - Single probe scanning

5.1.2. Two Probe Scanning

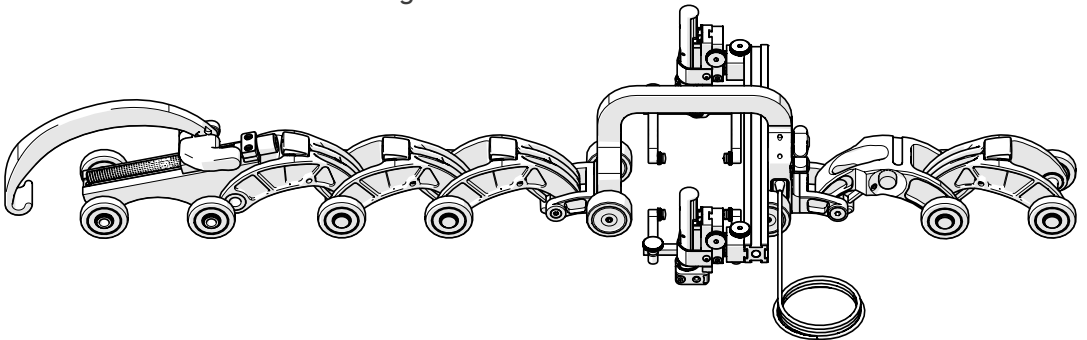

Fig. 19 - Two probe scanning

5.2. Reduced Width Link Setup And Adjustment

5.2.1. Attach a Frame Bar

To attach a frame bar to the reduced width link, follow these steps:

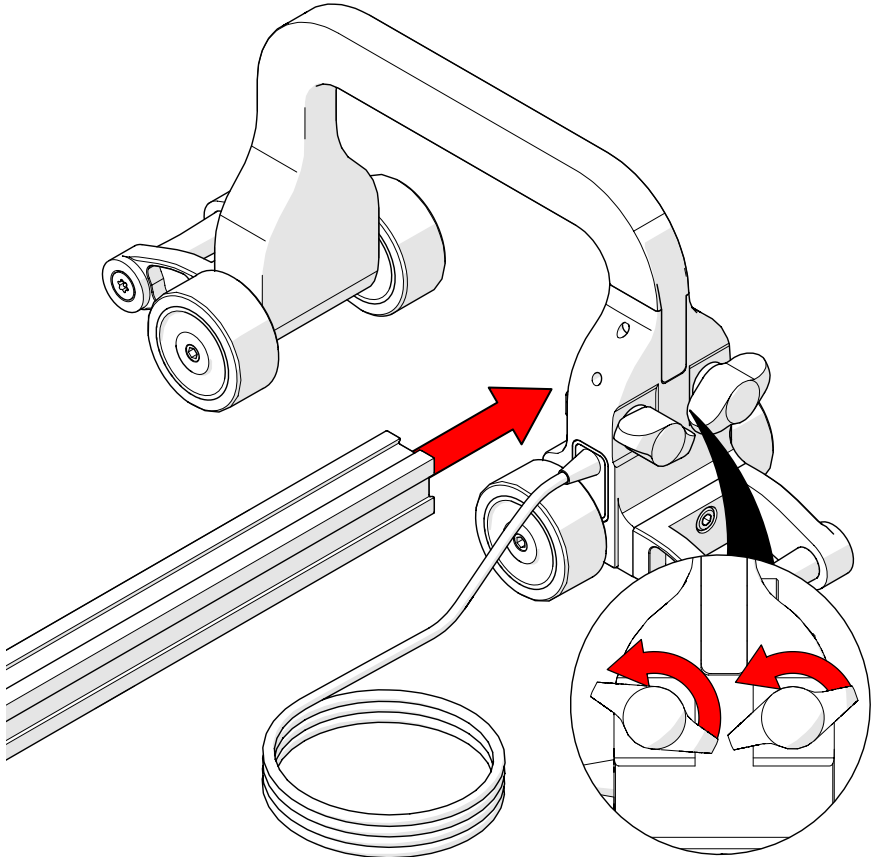

Fig. 20 - Loosen wing knobs and attach a frame bar

1. Loosen the black wing knobs counterclockwise (Fig. 20).
2. Align the dovetail groove of the frame bar with the dovetail nuts of the link. Slide the frame bar onto the link (Fig. 21).

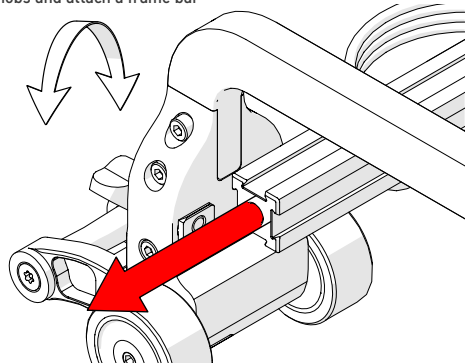

Fig. 21 - Tighten wing knobs

3. Position the frame bar where required and tighten the black wing knobs (Fig. 22).

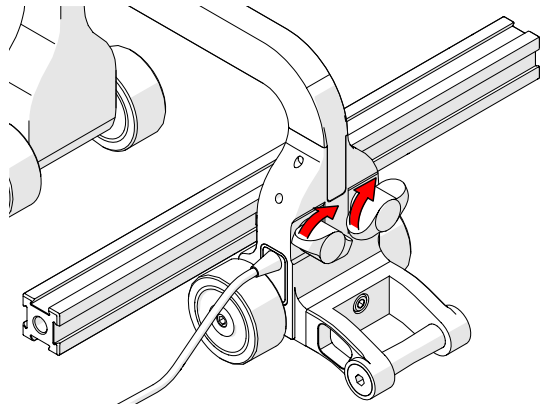

Fig. 22 - Tighten wing knobs

5.2.2. Wheel Removal/Installation

By hand, tightly grip the wheel to be removed. Using the supplied 3 mm hex driver (Fig. 15), loosen the wheel from the axle (Fig. 23). Reverse these steps to install wheels on the link.

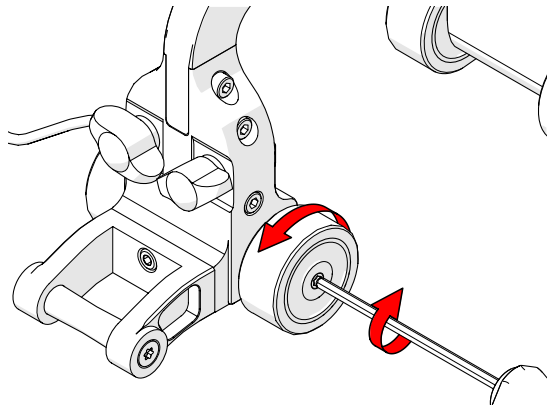

Fig. 23 - Tighten wing knobs

5.2.3. QuickLink Tail

Located at both ends of the reduced width link. A QuickLink Tail provides a connection point for QuickLinks (Fig. 24).

Use the supplied 3 mm hex driver to install or remove the tail.

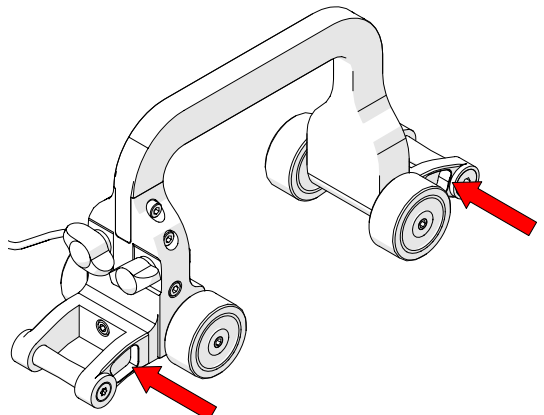

Fig. 24 - QuickLink Tail

5.3. Connecting QuickLinks & Dovetail Links

5.3.1. Connecting QuickLinks

To connect QuickLinks, see the following steps:

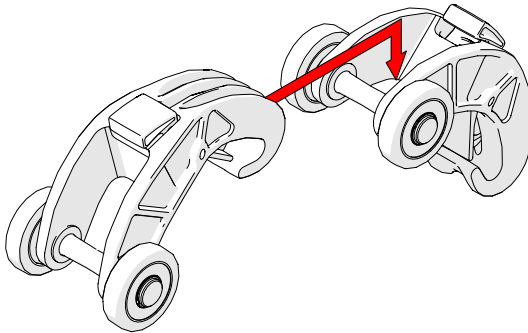

Fig. 25 - Lift the hook over the axle of the QuickLink

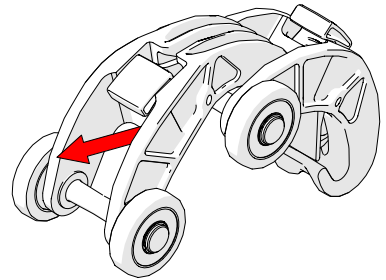

Fig. 26 - Pull the link backwards to secure catch

1. Lift the hook of the QuickLink over the axle of the QuickLink that is to be connected (Fig. 25).
2. Pull the QuickLink until you hear a click that ensures the latch has been set (Fig. 26).

5.3.2. Disconnecting QuickLinks

To disconnect QuickLinks, see the following steps:

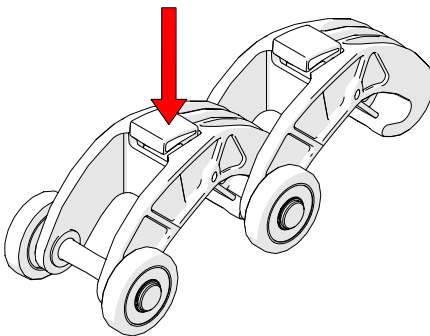

Fig. 27 - Press button

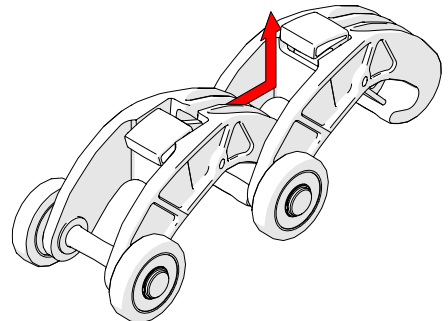

Fig. 28 - Slide QuickLink forward and lift

1. Press the button on the top of the QuickLink (Fig. 27).
2. While pressing the button, slide the QuickLink forward and up, clearing the hook of the QuickLink from the 2nd QuickLink's axle (Fig. 28).

5.3.3. Disconnecting the Dovetail QuickLink

To disconnect Dovetail QuickLinks, see the following steps:

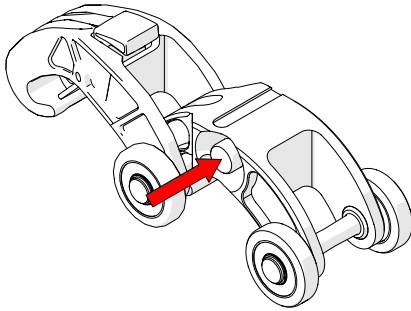

Fig. 29 - Press red button

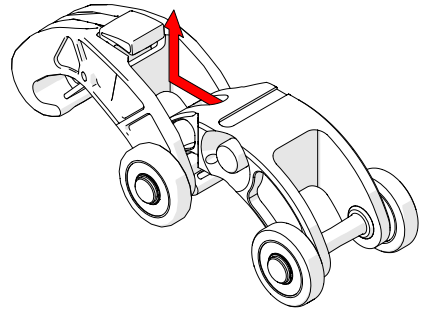

Fig. 30 - Slide Dovetail QuickLink forward and lift

1. Press the button on the side of the Dovetail QuickLink (*Fig. 29*).
2. While pressing the red button, slide the Dovetail QuickLink forward and up, clearing the hook of the Dovetail QuickLink from the 2nd QuickLink's axle (*Fig. 30*).

5.4. Vertical Probe Holder

- A Latch
- B Probe Holder Adjustment Knob
- C Vertical Adjustment Knob
- D Pivot Buttons
- E Probe Holder Arms
- F Yoke
- G Probe Holder Arm Adjustment Knob
- H Transverse Adjustment Screw
- I Frame Bar

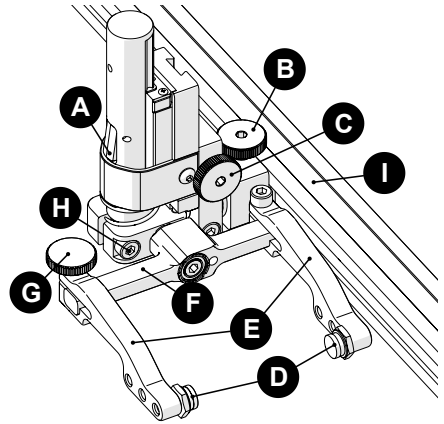

Fig. 31 - Vertical probe holder

5.4.1. Probe Holder Setup

To mount a UT wedge in the probe holder, follow these steps:

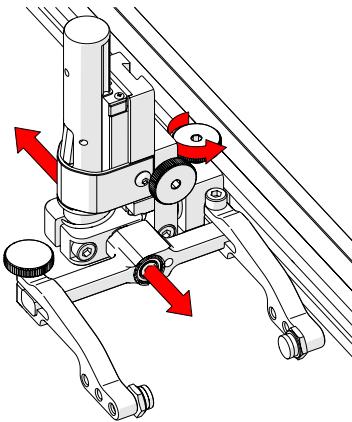

Fig. 32 - Adjust on frame bar

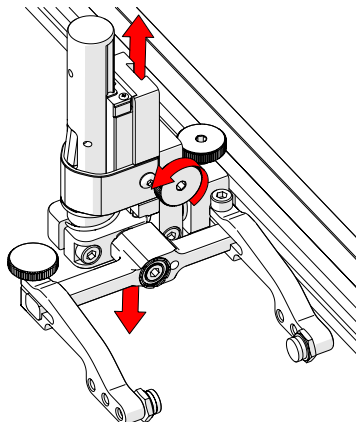

Fig. 33 - Vertical adjustment

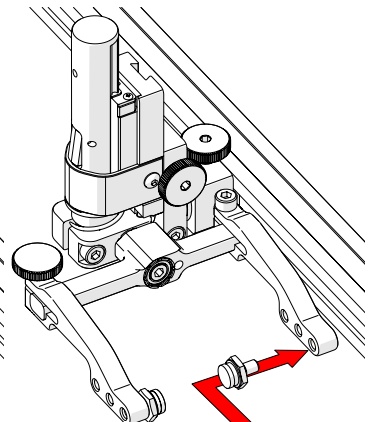

Fig. 34 - Place buttons

1. The probe holder adjustment knob allows the probe holder to be attached to a frame bar, as well as horizontal positioning on a frame bar (Fig. 32).
2. The vertical adjustment knob allows the vertical probe holder height adjustment (Fig. 33).
3. Position the pivot buttons where necessary. When narrow scanning footprint is required, use the pivot button holes closest to the yoke (Fig. 34).

TIP: Probe pivoting may be impeded when closer to the yoke.

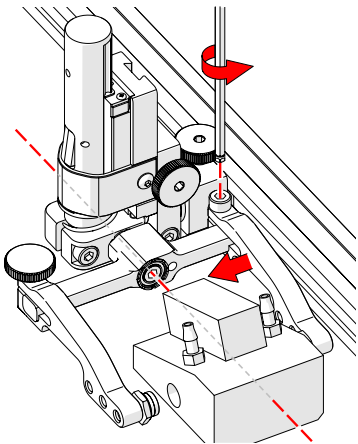

Fig. 35 - Adjust inner arm

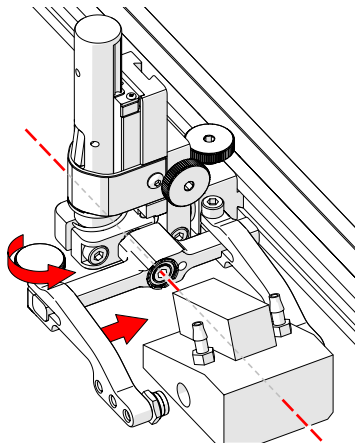

Fig. 36 - Adjust outer arm

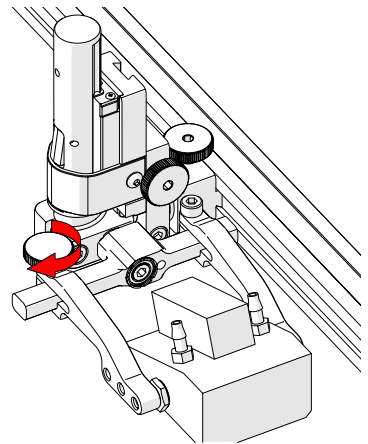

Fig. 37 - Tighten arm knob

4. Position the wedge on the inner probe holder arm.

TIP: The probe holder yoke can accommodate many different probe and wedge sizes of varying widths. It is best to centre the wedge with the yoke's pivot axis. This can reduce wedge tipping when scanning. Position the inner probe holder arm accordingly (Fig. 35) using the supplied 3 mm hex driver (Fig. 15).

5. Loosen the probe holder arm adjustment knob (Fig. 36) and slide the probe holder arm along the yoke pinching the wedge in place.
6. Tighten the probe holder arm adjustment knob (Fig. 37).

5.4.2. Probe Holder Vertical Adjustment

To adjust the probe holder vertically, follow these steps:

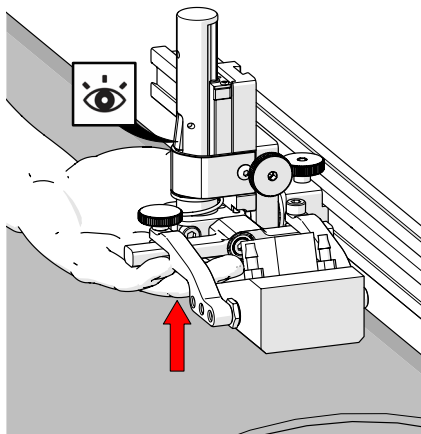

Fig. 38 - Latch probe holder

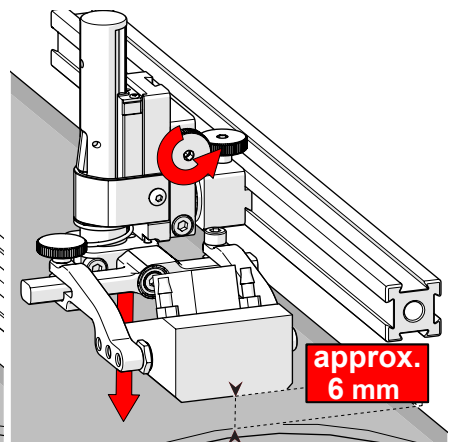

Fig. 39 - Lower toward scan surface

1. Ensure the probe holder is in the latched upper position. Lift the probe holder until the latch is fully exposed and snaps out to lock (Fig. 38).
2. Loosen the vertical adjustment knob and slide the probe holder down until the wedge is approximately 6 mm (¼ in) above inspection surface (Fig. 39).
3. Tighten the vertical adjustment knob (Fig. 39).

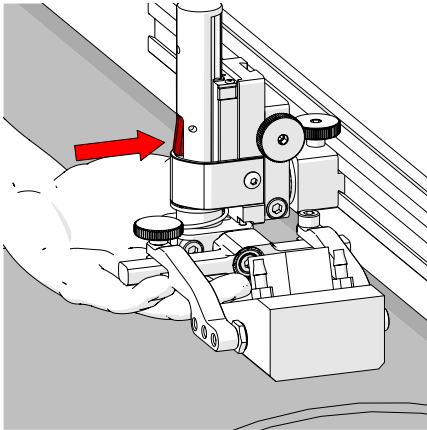

Fig. 40 - Press latch button

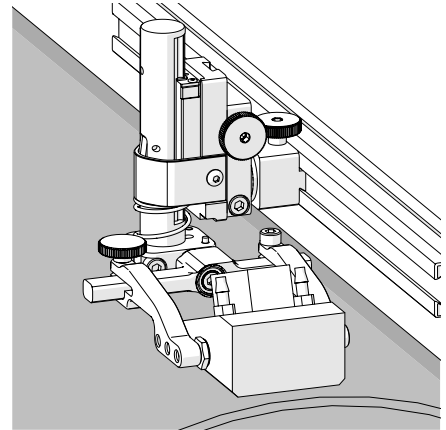

Fig. 41 - Lower toward scan surface

4. Lift the yoke slightly and press the latch button (Fig. 40), then slowly lower towards scanning surface to apply spring pressure to the wedge (Fig. 41).

TIP: If less spring force is desired, refer to step 2 and place the wedge approximately 20 mm (¾ in) above the inspection surface.

5.4.3. Probe Holder Transverse Adjustment

To adjust the probe holder's transverse angle, follow these steps:

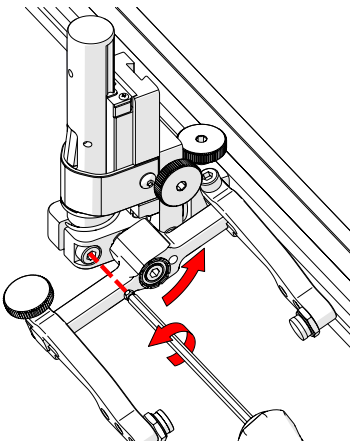

Fig. 42 - Loosen 3 mm screw

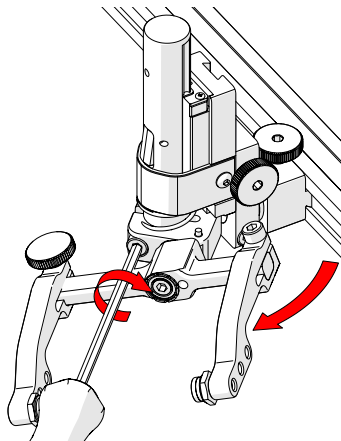

Fig. 43 - Rotate and tighten

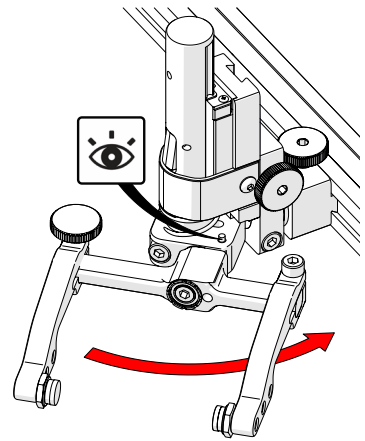

Fig. 44 - Stop post locates 90°

1. Ensure the probe holder is in latched, upper position (*Fig. 38*).
2. Using the supplied 3 mm hex driver loosen the transverse adjustment screw (*Fig. 42*) and rotate the yoke about the vertical shaft achieving the desired angle.
3. Tighten the transverse adjustment screw (*Fig. 43*).

To return the transverse adjustment to neutral (90°). The probe holder must be in the latched, upper position (*Fig. 38*). Rotate the yoke until the stop post contacts the base of the probe holder (*Fig. 44*). Then tighten the transverse adjustment screw.

5.4.4. Probe Holder Longitudinal Adjustment

To adjust the probe holder's vertical angle for longitudinal scanning, follow these steps:

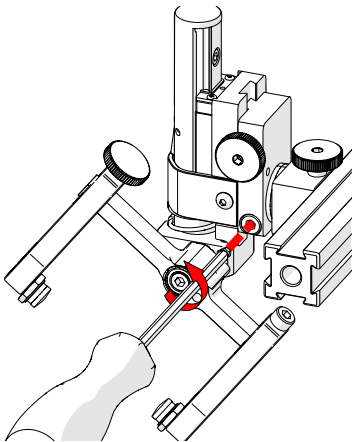

Fig. 45 - Loosen 3 mm screw

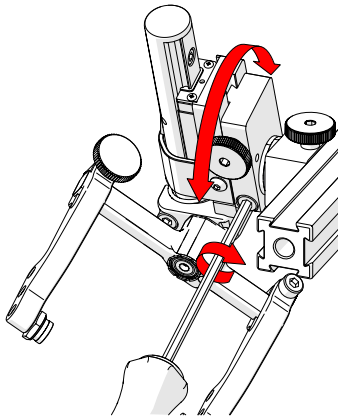

Fig. 46 - Rotate to position

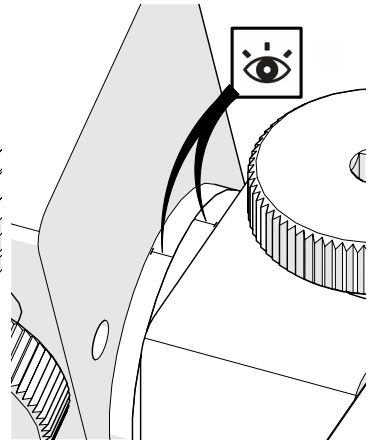

Fig. 47 - Line up markers

1. Ensure the probe holder is in latched, upper position (*Fig. 38*).
2. Using the supplied 3 mm hex driver (*Fig. 15*), loosen the longitudinal adjustment screw (*Fig. 45*).
3. Rotate the main body of the probe holder until it is at the desired angle.
4. Tighten the longitudinal adjustment screw (*Fig. 46*).

To return the longitudinal adjustment to neutral (90°). Line up the longitudinal adjustment indicator markers (*Fig. 47*).

5.4.5. Probe Holder Left/Right Conversion

To reverse the probe holder, follow these steps:

NOTE: To perform this operation, the 1.5 mm hex wrench (Fig. 17) is required.

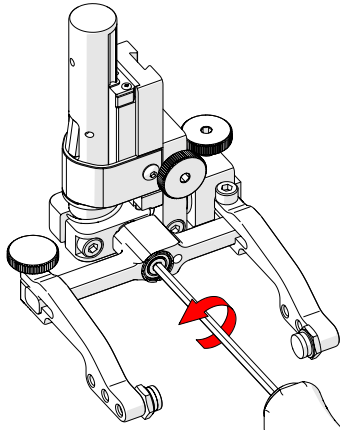

Fig. 48 - Unscrew yoke pivot screw

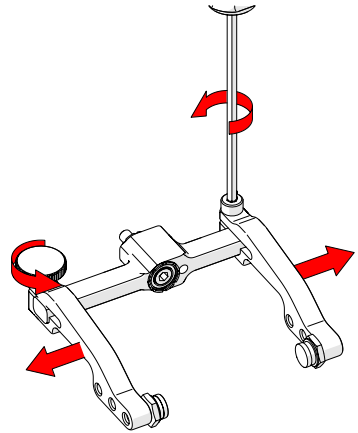

Fig. 49 - Remove probe holder arms

1. Ensure the probe holder is in latched, upper position (Fig. 38).
2. Using the supplied 3 mm hex driver (Fig. 15), unscrew the yoke pivot screw and remove the yoke (Fig. 48).
3. Loosen the probe holder arm adjustment knob and the arm clamp screw. Slide the probe holder arms off the yoke (Fig. 49).

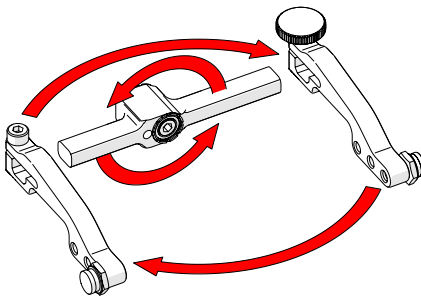

Fig. 50 - Flip yoke and reverse arms

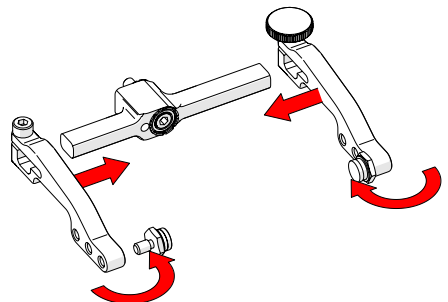

Fig. 51 - Attach arms & move buttons

4. Flip the yoke 180° and swap the probe holder arms (Fig. 50).
5. Place the pivot buttons on the inside of the probe holder arms (Fig. 51) using a 3/8 in wrench (Fig. 16).

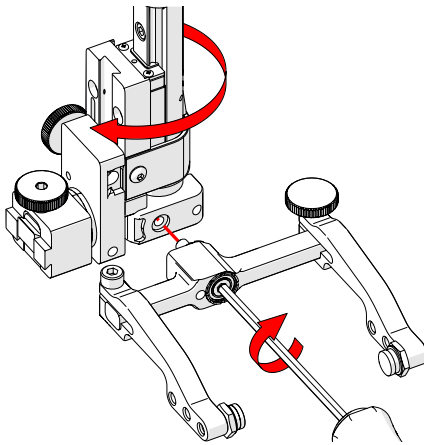

Fig. 52 - Screw yoke to opposite side

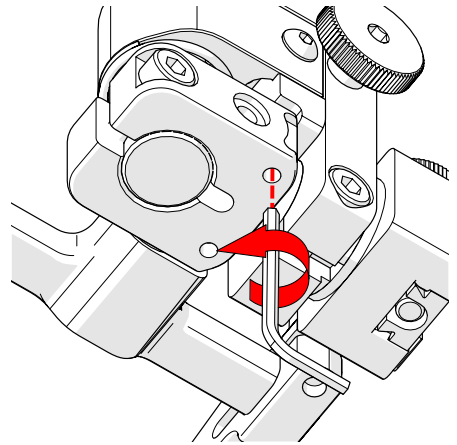

Fig. 53 - Lower 90° stop post

6. Mount the yoke to the opposite side of the base using the supplied 3 mm hex driver (Fig. 52).

TIP: Keep the yoke level with the base to ensure no conflicts with the plunger/set screw attached to the yoke.

7. Locate the recessed M3 screw (stop post) on the bottom of the probe holder. Unscrew the stop post using a 1.5 mm hex wrench until it has cleared all obstructions. Do not remove the stop post (Fig. 53).

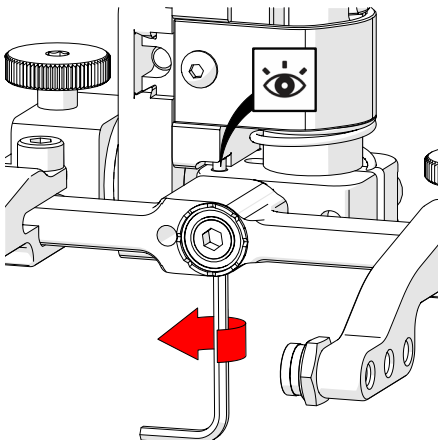

Fig. 54 - Raise opposite 90° stop post

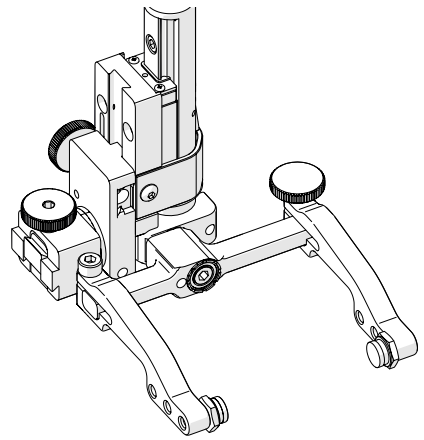

Fig. 55 - Reversed probe holder

8. Raise the stop post on the opposite side until the side of the post contacts the 90° stop point on the probe holder's base (Fig. 54).

5.5. Pivot Buttons

Available in various shapes and sizes, fitting different wedge dimensions (see *Pivot Button Style on page 40*).

Use the supplied 3/8 in wrench (Fig. 16) to remove and install pivot buttons (Fig. 56).

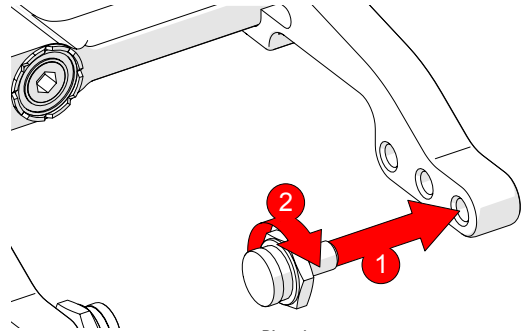

Fig. 56 - Pivot buttons

5.6. Cable Management System

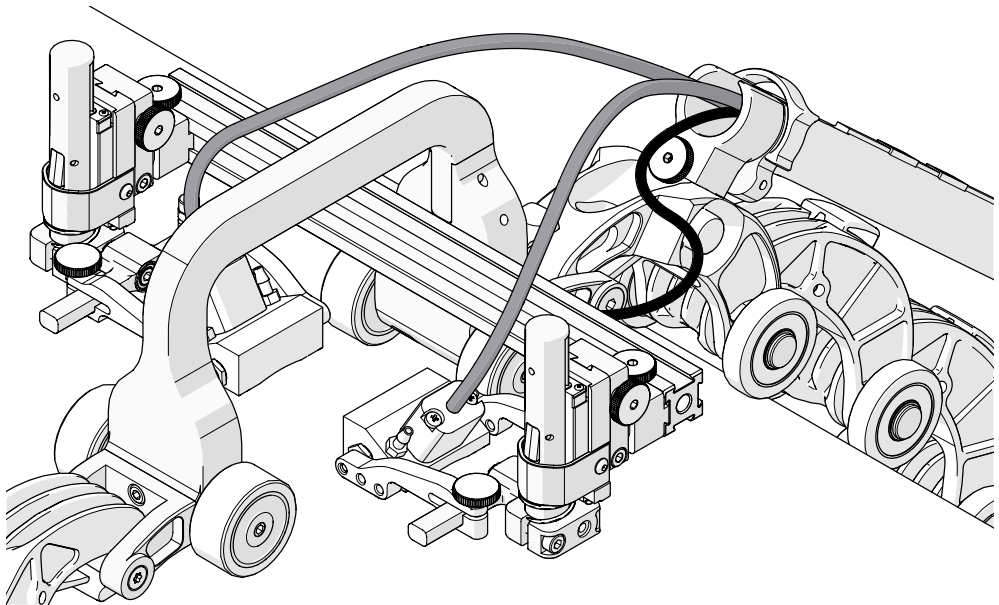

Fig. 57 - Cable management

The cable management provides a means of bundling and protecting cables and hoses that connect to the scanner.

5.6.1. Cable Management Dovetail Mount

To attach cable management, follow these steps:

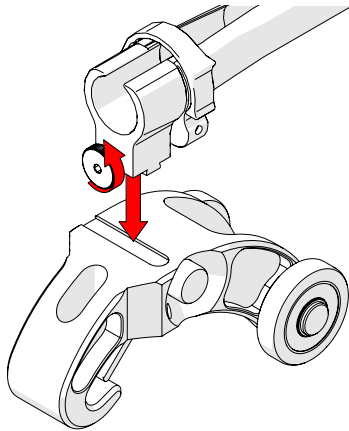

Fig. 58 - Loosen and slide on

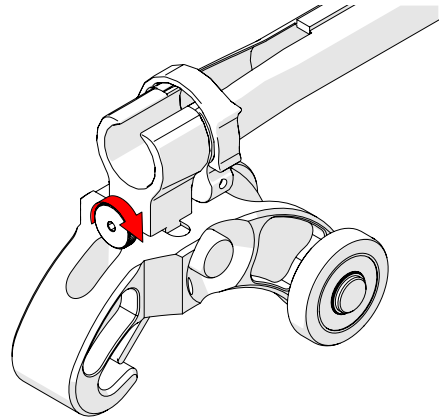

Fig. 59 - Tighten knob

1. Loosen the knob on the cable management dovetail mount. Position the mount onto the Dovetail QuickLink (Fig. 58).
2. Once centred on the Dovetail QuickLink, tighten the cable management's dovetail mount knob (Fig. 59).

5.6.2. Cable Management Setup

Cable management is available in a variety of lengths and provides a means of bundling and protecting cables and hoses that run to a scanner.

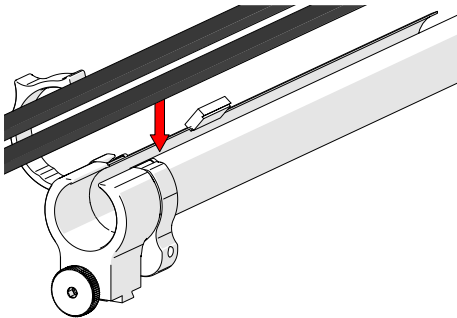

Fig. 60 - Insert cables and hoses

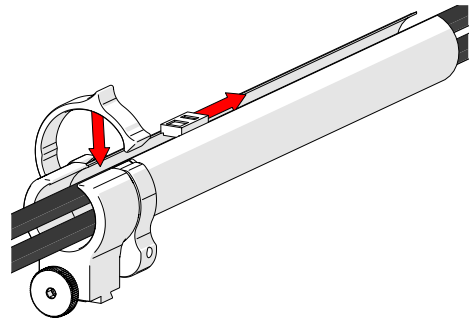

Fig. 61 - Zip up to close

1. Open the zipper of the cable management. Begin at the tube's dovetail mount and place the cabling in the tube (Fig. 60).
2. Follow the cable placement, zipping the tube closed (Fig. 61).

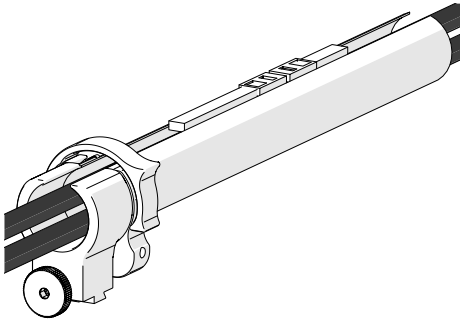

Fig. 62 - Zip opposite end

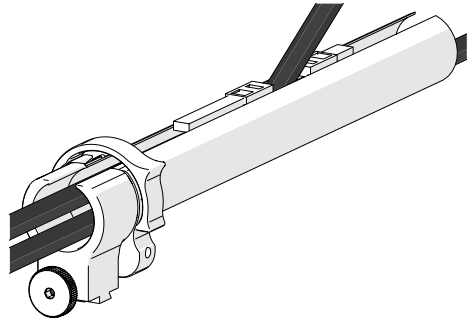

Fig. 63 - Flexibility

3. Once the cable is placed the entire length of the tube, bring the zipper from the tube's opposite end, meeting at any point in the middle (Fig. 62).
4. When necessary, the two zippers may be opened to allow cables to exit the tube anywhere between the ends (Fig. 63).

5.6.3. Clamp Setup

If the tube becomes disconnected from the cable management dovetail mount, follow these instructions to re-attach the tube and dovetail mount.

1. Loosen the clamp screw using the supplied 3 mm hex driver.
2. Slide the clamp around the tube first and then slide the tube around the outside of the cable management dovetail mount (Fig. 64). Align the zipper opening and the cable management dovetail mount opening.
3. Slide the clamp over the tube and cable management dovetail mount, pinching the tube in between (Fig. 65).
4. Tighten the clamp screw (Fig. 66).

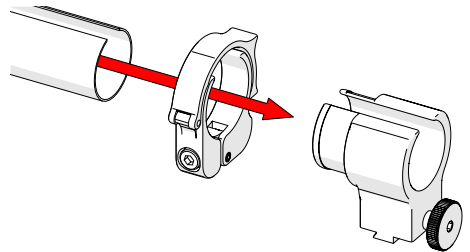

Fig. 64 - Slide tube around mount

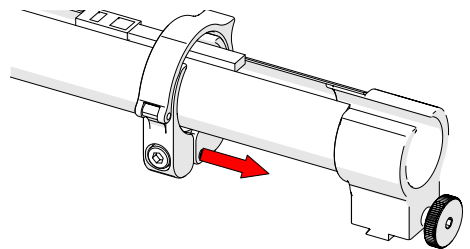

Fig. 65 - Slide clamp onto mount

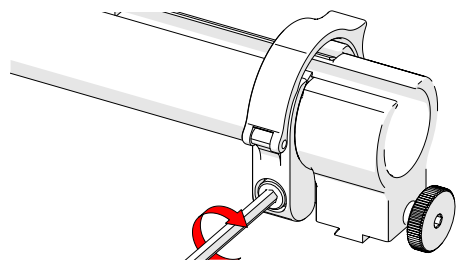

Fig. 66 - Tighten clamp screw

5.7. Magnetic Wheel Kit



WARNING! MAGNETIC MATERIAL. The magnetic wheel kit produce a magnetic field which may cause failure or permanent damage to items such as watches, memory devices, CRT monitors, medical devices or other electronics. People with pacemakers or ICD's must stay at least 25 cm (10 in) away.

When using a chain scanner is not appropriate, the magnetic wheel kit (Fig. 67) can replace the non-magnetic wheels on a **ROTIX** scanner body. Two sets of the magnetic wheel kits can also be used on the scanner body to double the magnetic force.

To install or remove wheels (see *Wheel Removal/Installation* on page 13).

NOTE: Do not use magnetic wheels with a chain assembly.

NOTE: Magnetic wheels may lose their magnetic properties if heated above 175°F (80° C).

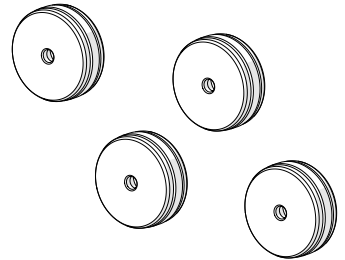

Fig. 67 - Magnetic wheel kit

5.8. Preamp Bracket

Compatible with most standard preamps, use screws or the optional velcro straps to attach a preamp to the preamp bracket.

Intended Use

- ▶ The preamp bracket is intended to mount objects (e.g. preamps, splitters, etc.) that:
- ▶ have a maximum weight of 1.36 kg (3 lb)
- ▶ are attached to the with a lanyard or probe cables strong enough to prevent the object from falling
- ▶ have smooth edges so as not to cut the bracket's velcro strap

5.8.1. Mounting Preamp Bracket

The preamp bracket mounts to any dovetail groove.

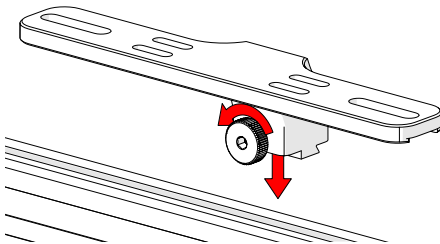

Fig. 68 - Loosen knob and mount to dovetail groove

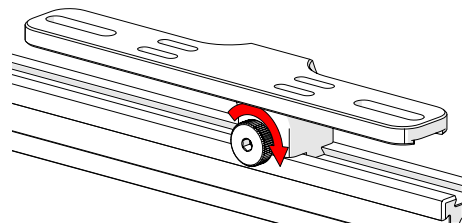

Fig. 69 - Tighten knob

1. Loosen the knob and align dovetail nut with the dovetail groove (Fig. 68).
2. Tighten the knob to lock the preamp bracket in place (Fig. 69).

5.8.2. Attaching Preamp with Screws

Use the adjustable screw mounting channel on the bottom of the bracket to attach a preamp (screws not included).

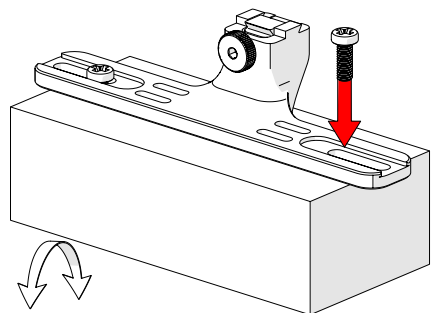

Fig. 70 - Attach preamp with screws

5.8.3. Attaching Preamp with Velcro Straps

To attach the preamp to the bracket using velcro straps (*sold separately*), follow these steps:

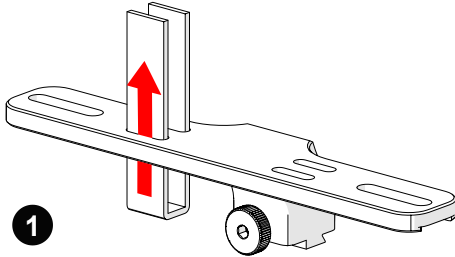

Fig. 71 - Insert velcro straps

1. Slide the velcro strap through the bracket's holes (Fig. 71).
2. Centre and place the preamp on the bracket wrapping the velcro around the preamp (Fig. 72).
3. Secure the preamp to the bracket attaching each side of the velcro (Fig. 73).

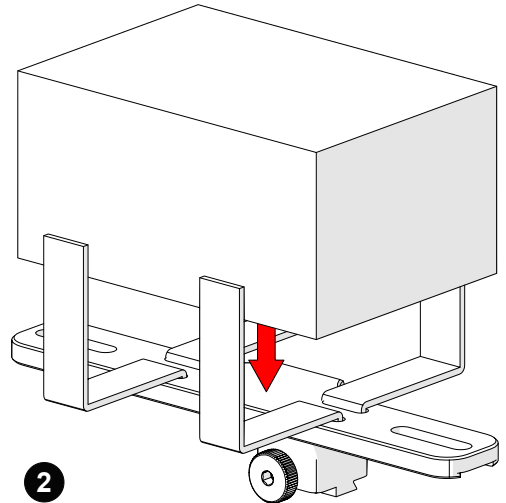

Fig. 72 - Place preamp and wrap velcro

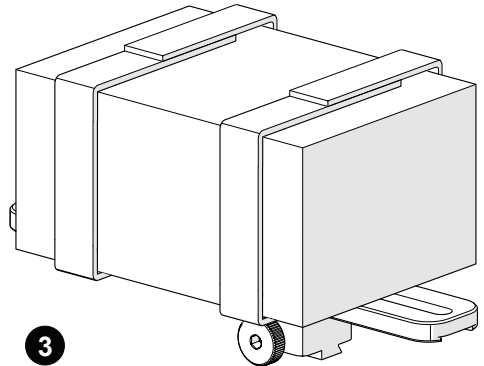

Fig. 73 - Mount bracket on a frame bar

OPERATION

6.1. Setup of ROTIX on a Scanning Surface

1. Determine the diameter of the pipe or tube to be scanned. Included in the **ROTIX** kit and this manual is a setup chart indicating the number of links required based on the diameter of the pipe or tubing (Fig. 74).

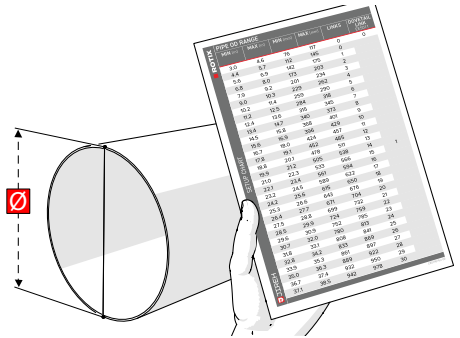

Fig. 74 - Refer to setup chart

2. Attach the appropriately sized frame bar (Fig. 75) to the reduced width link (see Attach a Frame Bar on page 12).

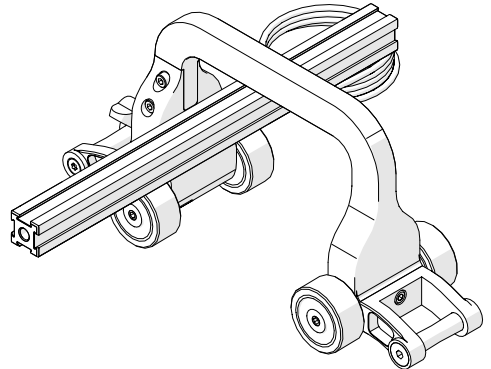

Fig. 75 - Attach frame bar

3. Assemble the appropriate configuration to the frame bar (Fig. 76). Install the wedge and probes that will be used (see Vertical Probe Holder on page 16).

TIP: The following example is a two probe configuration for a 30.4 cm (12 in) pipe diameter.

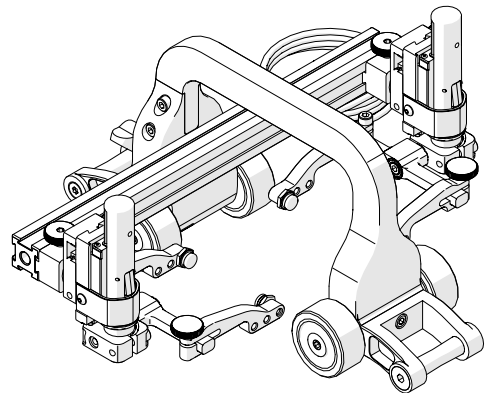

Fig. 76 - Mount probe holders

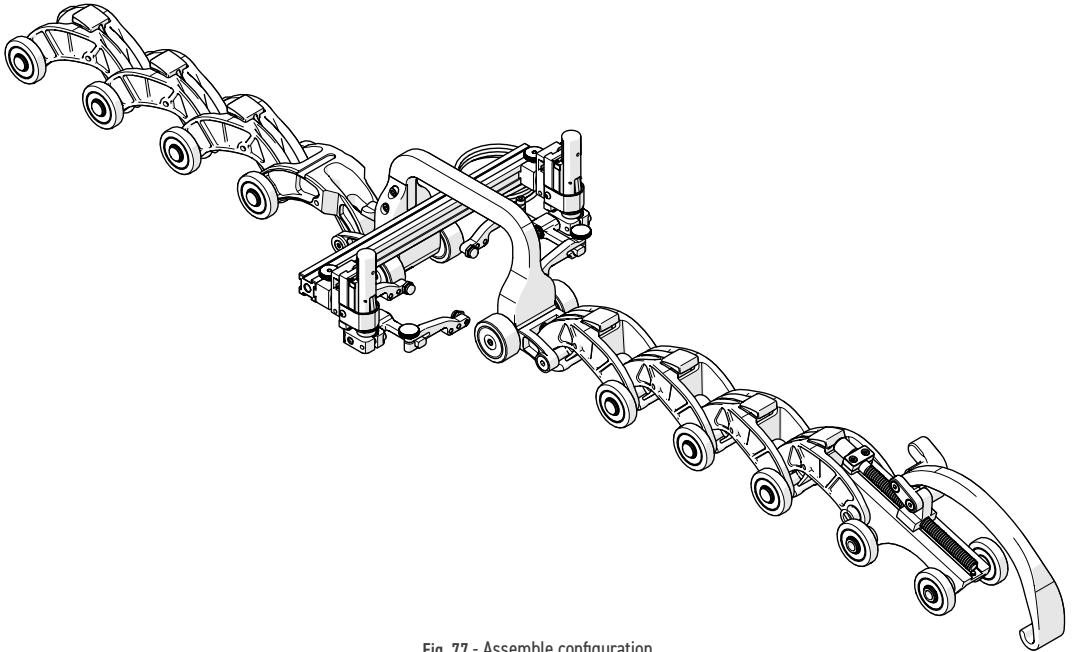

Fig. 77 - Assemble configuration

4. On a flat surface, connect the appropriate number of links (see *Vertical Probe Holder* on page 16) as indicated on the **ROTIX** setup chart. Arrange the link setup so the buckle and catch link will be 180° opposite the scanner body (Fig. 77).

TIP: Place the dovetail link directly behind the reduced width link.

5. Drape the configured assembly around the pipe/tube to be inspected (Fig. 78). Ensure the double wheel chain links straddle the weld (during two probe scanning).

NOTE: Ensure the scanner does not roll off the scan surface before securing the chain.

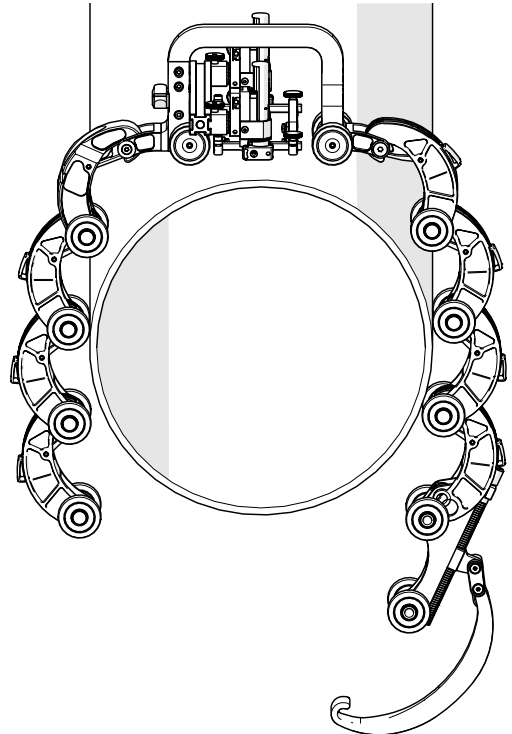

Fig. 78 - Place on pipe

- Bring the QuickLink Buckle's arm towards the opposite QuickLink. Hook the QuickLink Buckle's arm to the middle axle of the QuickLink (Fig. 79). The QuickLink Buckle adjustment knob (Fig. 80-1) may have to be loosened to allow the arm to reach the QuickLink.

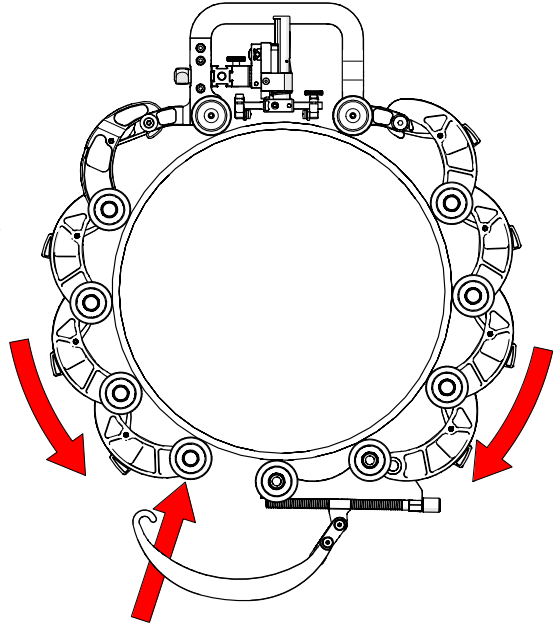

Fig. 79 - Hook QuickLink Buckle to QuickLink

- The tightness of the **ROTIX** on the pipe can be adjusted using the QuickLink Buckle adjustment knob (Fig. 80-1).

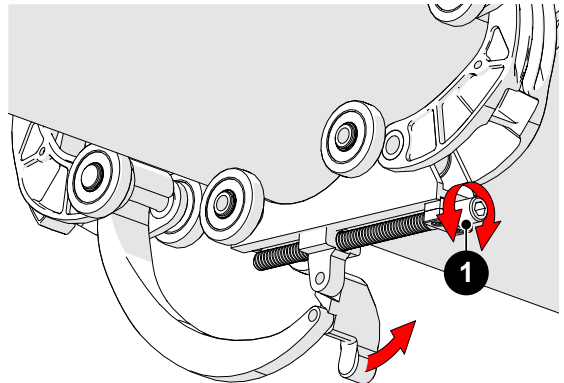

Fig. 80 - Adjust pressure of QuickLink Buckle

- Rotate the knob until the QuickLink Buckle's lever can be pushed down, locking the QuickLink Buckle in place (Fig. 81).

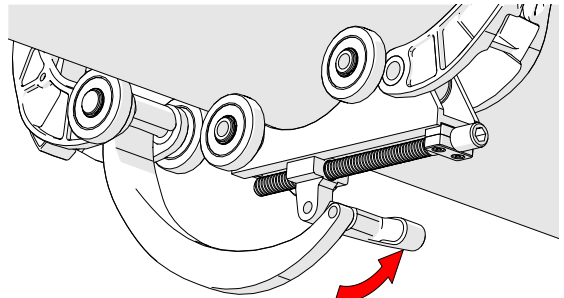

Fig. 81 - Press down to lock

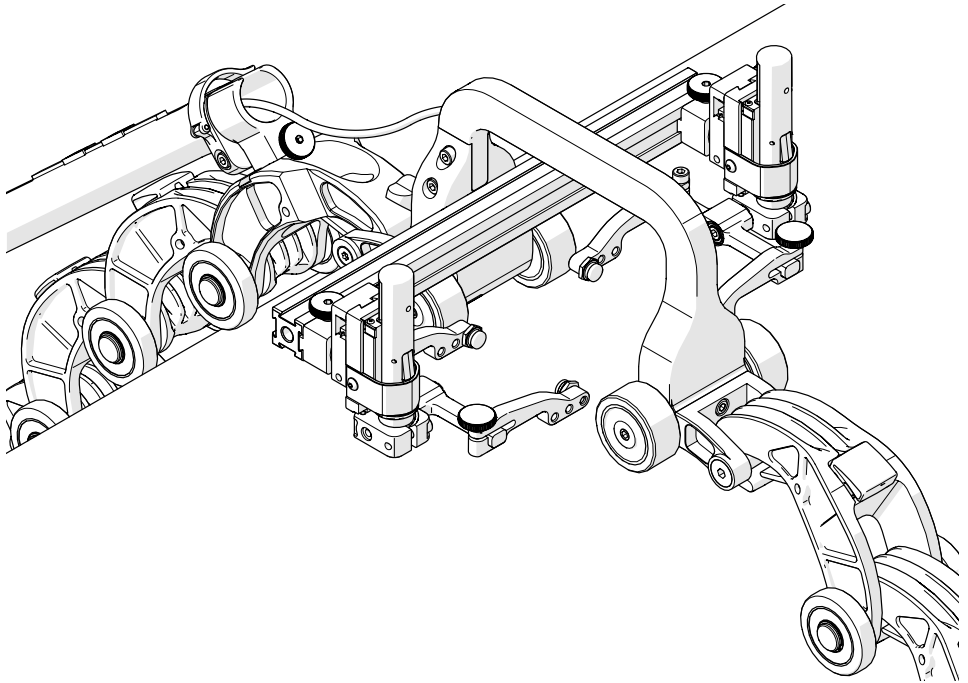

Fig. 82 - Configured four probe configuration

9. Route all cabling and hoses (*Only encoder cable shown*) to the cable management (*see Cable Management System on page 22*).
10. Lower probe holders to the scan surface (*see Vertical Probe Holder on page 16*).

MAINTENANCE

General cleaning of components is important to keep your system working well. All components that have no wiring or cables are completely waterproof. Components can be washed with warm water, dish soap and a medium bristle brush.

Before using the scanner, ensure all connectors are free of water and moisture.

NOTE: *All components with wiring, cables or electrical connections are splashproof. However, these components are **NOT** submersible.*

NOTE: *Never use strong solvents or abrasive materials to clean your scanner components.*

TROUBLESHOOTING

Problem	Possible Cause	Solution
The QuickLink chain is too loose/tight	Incorrect number of QuickLinks for proper scanner configuration.	Refer to the ROTIX setup chart (<i>see Reduced Width Chain Configuration Setup Chart on page 45</i>) for the required number of QuickLinks for the diameter of the pipe/tube to be scanned. Ensure the correct outer diameter measurement of the pipe/tube. Reset the scanner with the correct number of links.
	The QuickLink Buckle is incorrectly setup.	Adjust the tightness of the QuickLink Buckle (<i>see page 30</i>).
Insufficient probe contact.	The scanner is not set correctly.	Reconfigure the scanner as per instructions (<i>see Setup of ROTIX on a Scanning Surface on page 28</i>).

8.1. Technical Support

For technical support, contact Jireh Industries (*see "Jireh Industries Ltd." on page 1*).

SERVICE AND REPAIR



WARNING! DO NOT DISASSEMBLE. No user-serviceable parts. Disassembling any of the components in this product, beyond the instructions in this user manual, could void the regulatory certifications and/or effect the safety of the product.

SPARE PARTS

To order accessories or replacement parts for your ROTIX system.
(contact Jireh Industries Ltd. on page 1)

NOTE: These drawings are for parts order. This is not a list of kit contents.

10.1. Kit Components

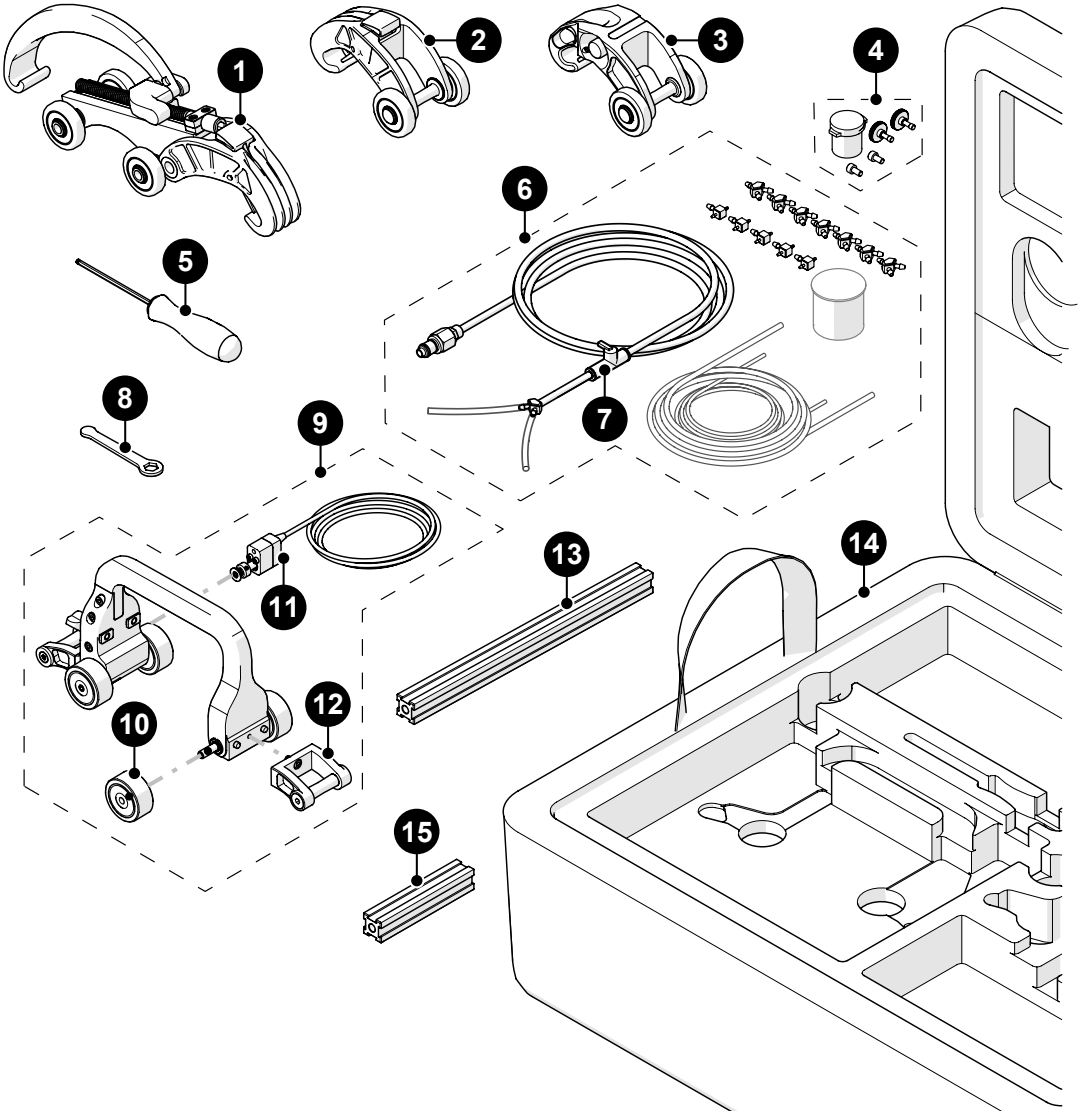

Fig. 83 - ROTIX parts

BOM ID	Part #	Description
1	EES014	QuickLink buckle
2	EES004	QuickLink
3	EES019	Dovetail QuickLink
4	PHG014	2 probe spare parts kit
5	EA414	Hex driver, 3 mm (0.118 in)
6	CMG007	Irrigation kit, 2-4 probe
7	LA034	Irrigation Shutoff Valve
8	EA470	10 mm (3/8 in) wrench
9	CES104-	Reduced width ROTIX link (see Encoder Connector Type)
10	CES012	Non-magnetic wheel
11	CES047-__	Reduced width encoder assembly (see Encoder Connector Type)
12	CES095	QuickLink tail
13	BG0038-25	Frame bar, 20 cm
14	CEA041	ROTIX case
15	BG0038-10	Frame bar, 10 cm

10.1.1. Encoder Connector Type

Connector Type	Company/Instrument	Connector Type	Company/Instrument
B	Olympus OmniScan MX Zetec Topaz	G	Sonotron Isonic 25xx
C	Olympus Focus LT Zetec Z-Scan Eddyfi Ectane 2	U	Sonatest Veo / Prisma
E	Olympus OmniScan SX/MX2/X3 M2M MANTIS/GEKKO LEMO	V	Pragma PAUT
F	TD (Technology Design)	AD	Sonatest Veo / Prisma - Single Axis

NOTE: Additional encoder connector styles are available.
(contact Jireh Industries Ltd. on page 1)

10.2. Accessories

10.2.1. Cable Management

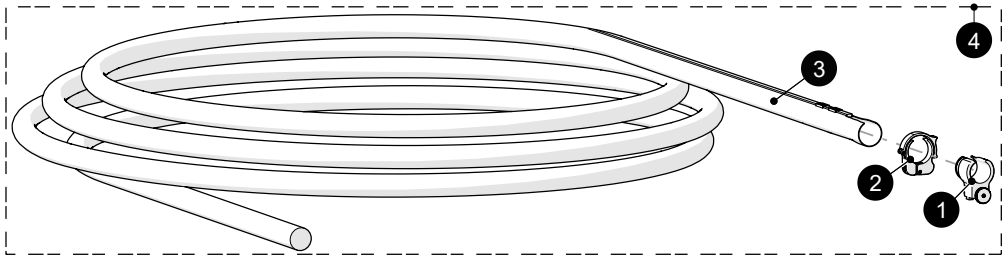

BOM ID	Part #	Description
1	CES067	Cable Management Mount, Dovetail Mount
2	CES066	Cable Management Clamp, Dovetail Mount
3	<i>See Cable Management Slewing</i>	
4	CES044- <u> </u>	Cable Management: Dovetail (<i>see cable management slewing</i>)

Fig. 84 - Cable management

10.2.1.1 Cable Management Slewing

Part #	Length
CX0141	4.5 m (14.8 ft)
CX0145	9.5 m (31.2 ft)

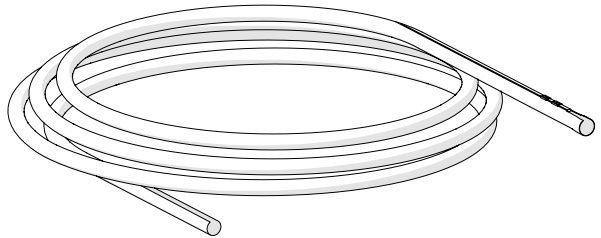

Fig. 85 - Cable management slewing

10.2.2. Preamp Bracket

BOM ID	Part #	Description
1	CES029	Preamp Bracket
2	CES029-V	Preamp Bracket with Velcro

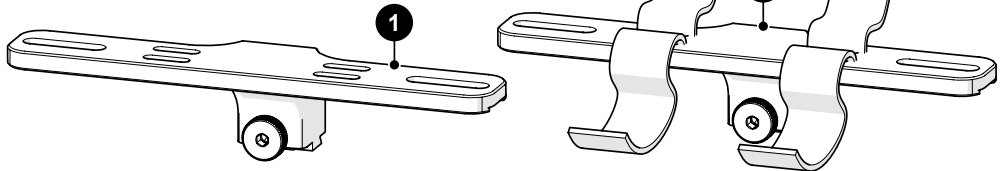

Fig. 86 - Preamp bracket

10.2.3. Magnetic Wheel Kit

Part #	Description
BTG014	Magnetic Wheel Kit

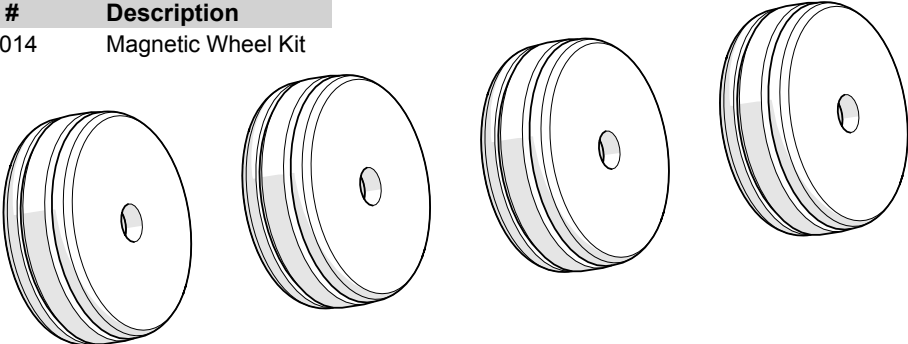
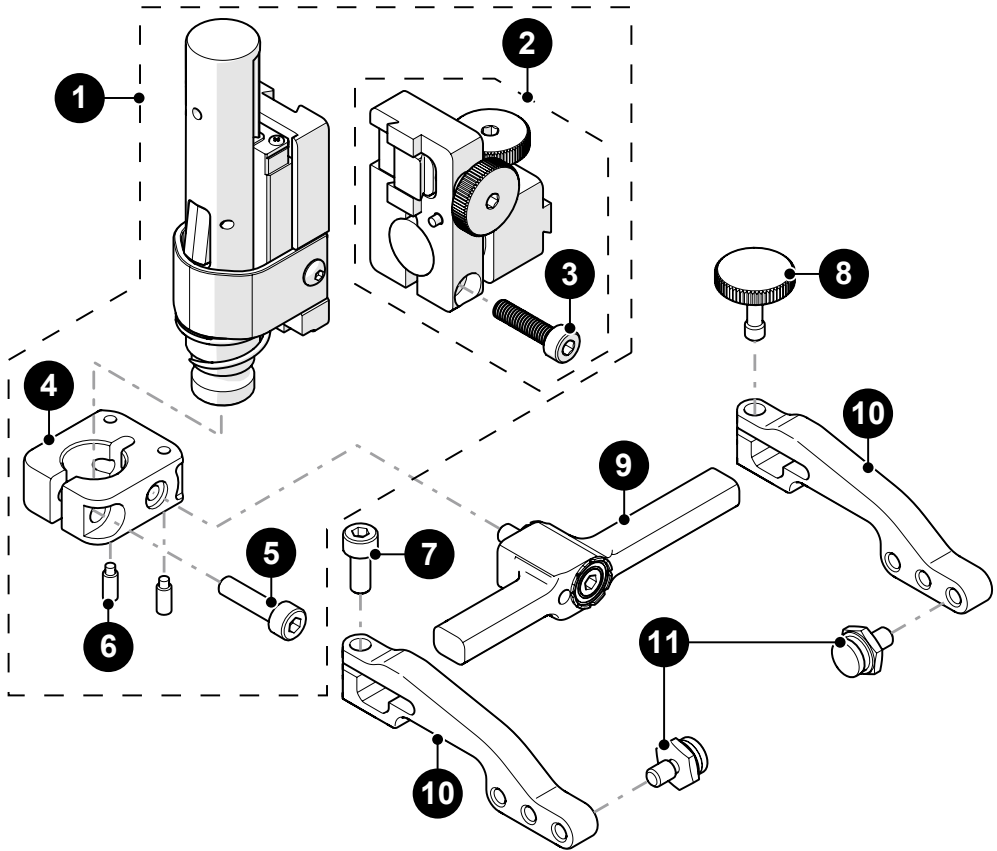

Fig. 87 - Magnetic wheel kit

10.3. Vertical Probe Holder Parts



BOM ID	Part #	Description
1	PHS028	Vertical Probe Holder Subassembly
2	PHS061	Vertical Probe Holder Sub-Assembly: pivoting mount
3	MA307	Screw, M4x16 mm High Strength SST SHCS
4	PH0087	Vertical Probe Holder Base
5	MD050-016	SHCS, M4 x 0.7 x 16 mm, SST
6	MA096	Screw, M3x8 mm Dog Point Set, SST
7	MD050-010	SHCS, M4 x 0.7 x 10 mm, SST
8	PH0082	Knurled Knob, M4 x 0.7 x 10 mm, 3 mm stand off, SST
9		see Yoke Style
10		see Arm Style
11	PH0011- <u> </u>	Pivot Button Style (see Pivot Button Style)

Fig. 88 - Vertical probe holder

10.4. Probe Holder Components

10.4.1. Arm Style

Arm Style	Part #	Image	Arm Style	Part #	Image
A Standard, Flat	PH0090		B Short, Flat	PH0089	
C Long, Flat	PH0099		D Standard, Drop	PH0093	
E Short, Drop	PH0092		F Long, Drop	PH0094	
G Standard, Extra-Drop	PH0096		H Short, Extra-Drop	PH0095	
I Extra-Short, Flat	PH0159		J Extra-Short, Drop	PH0161	

Fig. 89 - Probe holder arm selection

10.4.2. Yoke Style

Yoke Style	Part #	Length	Image	Yoke Style	Part #	Length	Image
S Standard	PHS052	6.3 cm (2.47 in)		W Wide	PHS063	7.9 cm (3.06 in)	

Fig. 90 - Probe holder yoke selection

10.4.3. Pivot Button Style

Pivot Hole Size	Wedge Type	Image	Pivot Hole Size	Wedge Type	Image
01 8.0 mm (0.315 in)	Olympus PA		02 5.0 mm (0.197 in)	Olympus TOFD	
03 2.7 mm (0.106 in)	Sonatest DAAH PA		04 9.5 mm (0.375 in)	-	
06 3.0 mm (0.118 in)	-		07 2.3 mm (0.09 in)	-	
08 Conical Head	-		09 5 mm (0.197 in) Internal	Zetec PA/TOFD	

Fig. 91 - Pivot button selection

NOTE: Additional probe holder pivot button types are available. (contact Jireh Industries Ltd. on page 1)

10.5. Variable Components

10.5.1. Frame Bars

Part #	Length	Image	Part #	Length	Image
BG0038-05	5 cm (1.97 in)		BG0038-10	10 cm (3.94 in)	
BG0038-15	15 cm (5.91 in)		BG0038-20	20 cm (7.87 in)	
BG0038-25	25 cm (9.84 in)		BG0038-30	30 cm (11.81 in)	
BG0038-35	35 cm (13.78 in)		BG0038-40	40 cm (15.75 in)	
BG0038-45	45 cm (17.72 in)		BG0038-50	50 cm (19.69 in)	
BG0038-55	55 cm (21.65 in)				

Fig. 92 - Frame bar selection

10.6. Case

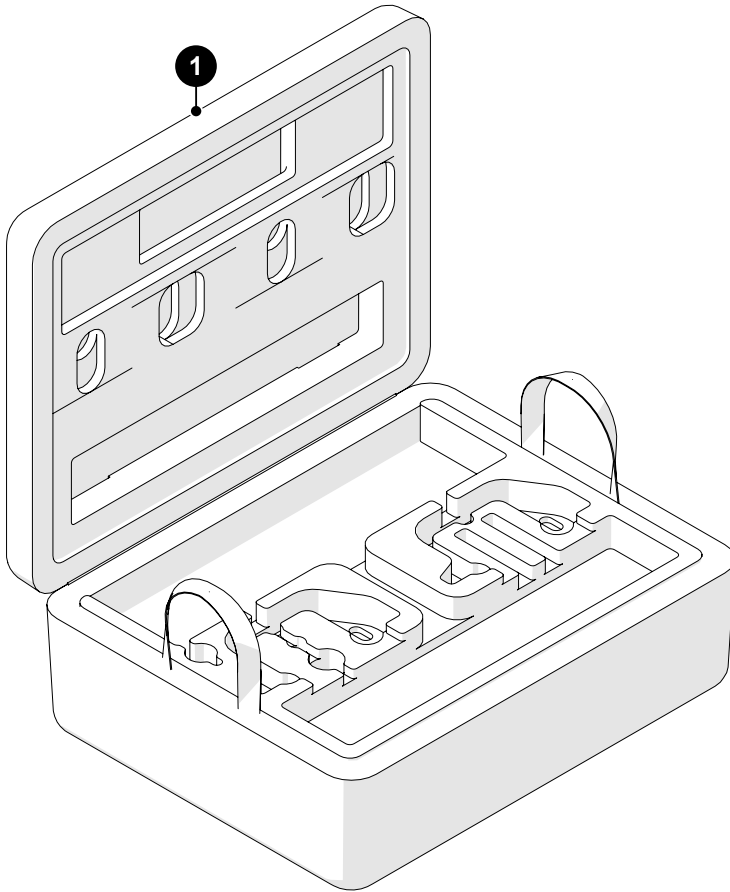

BOM ID	Part #	Description
1	CEA013	ROTIX Reduced Width Case

Fig. 93 - Case

DISPOSAL

WEEE Directive

In accordance with European Directive on Waste Electrical and Electronic Equipment (*WEEE*), this symbol indicates that the product must not be disposed of as unsorted municipal waste, but should be collected separately. Refer to Jireh Industries for return and/or collection systems available in your country.



LIMITED WARRANTY

WARRANTY COVERAGE

Jireh Industries warranty obligations are limited to the terms set forth below: Jireh Industries Ltd. (“Jireh”) warrants this hardware product against defects in materials and workmanship for a period of THREE (3) YEARS from the original date of purchase. If a defect exists, at its option Jireh will (1) repair the product at no charge, using new or refurbished replacement parts, (2) exchange the product with a product that is new or which has been manufactured from new or serviceable used parts and is at least functionally equivalent to the original product, or (3) refund the purchase price of the product. A replacement product/part assumes the remaining warranty of the original product or ninety (90) days from the date of replacement or repair, whichever provides longer coverage for you. When a product or part is exchanged, any replacement item becomes your property and the replaced item becomes Jireh’s property. When a refund is given, your product becomes Jireh’s property.

OBTAINING WARRANTY SERVICE

To utilize Jireh’s warranty service you must ship the product, at your expense, to and from Jireh Industries. Before you deliver your product for warranty service you must phone Jireh and obtain an RMA number. This number will be used to process and track your product. Jireh is not responsible for any damage incurred during transit.

EXCLUSIONS AND LIMITATIONS

This Limited Warranty applies only to hardware products manufactured by or for Jireh Industries. This warranty does not apply: (a) to damage caused by accident, abuse, misuse, misapplication, or non-Jireh products; (b) to damage caused by service (including upgrades and expansions) performed by anyone who is not a Jireh Authorized Service Provider; (c) to a product or a part that has been modified without the written permission of Jireh.

Jireh Industries Ltd.

53158 Range Road 224
Ardrossan AB T8E 2K4
Canada

780.922.4534

jireh.com

All brands are trademarks or registered trademarks of their respective owners and third-party entities.

Changes or modifications to this unit or accessories not expressly approved by the party responsible for compliance could void the user's authority to operate the equipment.

All specifications are subject to change without notice.

© 2023 - 2025 Jireh Industries Ltd.

APPENDIX

13.1. Reduced Width Chain Configuration Setup Chart

PIPE OD RANGE					QUICKLINKS EES004	DOVETAIL QUICKLINK EES019
MIN (in)	MAX (in)	MIN (mm)	MAX (mm)			
4.2	5.3	107	135	0	1	
5.4	6.7	137	170	1		
6.7	7.9	170	201	2		
7.9	9.1	201	231	3		
9.1	10.3	231	262	4		
10.3	11.5	262	292	5		
11.5	12.6	292	320	6		
12.6	13.7	320	348	7		
13.7	14.8	348	376	8		
14.8	15.9	376	404	9		
15.9	17.0	404	432	10		
17.0	18.3	432	465	11		
18.1	19.4	460	493	12		
19.2	20.6	488	523	13		
20.3	21.6	516	549	14		
21.4	22.6	544	574	15		
22.5	23.7	572	602	16		
23.5	24.8	597	630	17		
24.6	25.9	625	658	18		
25.7	27.0	653	686	19		
26.8	28.1	681	714	20		
27.9	29.1	709	739	21		
28.9	30.2	734	767	22		
30.0	31.3	762	795	23		
31.1	32.4	790	823	24		
32.2	33.5	818	851	25		
33.2	34.5	843	876	26		
34.3	35.6	871	904	27		
35.4	36.7	899	932	28		
36.5	37.8	927	960	29		
37.5	38.9	953	988	30		

CE0204 Rev 01



Jireh Industries Ltd.
53158 Range Road 224
Ardrossan, Alberta
Canada
T8E 2K4

780-922-4534

jireh.com