



MOTIX

EJ0020 Rev 00.5

Automated Chain Scanner

SAFETY WARNINGS / PRECAUTIONS

KEEP THIS MANUAL – DO NOT LOSE

THIS MANUAL IS PART OF THE **MOTIX** SYSTEM AND MUST BE RETAINED FOR THE LIFE OF THE PRODUCT. PASS ON TO SUBSEQUENT OWNERS.

Ensure any amendments are incorporated with this document.



WARNING! The **MOTIX** is designed for a specific use. Using the **MOTIX** outside of its intended use is dangerous. Failure to comply with the warnings, instructions, and specifications in this manual could result in **SEVERE INJURY** or **DEATH**. Read and understand this manual before using.



WARNING! **ELECTRICAL CORDS CAN BE HAZARDOUS.** Misuse can result in **FIRE** or **DEATH by ELECTRICAL SHOCK**. Inspect thoroughly before each use. Do **NOT** use if damaged. Do **NOT** use when wet. Keep away from water. Do **NOT** drive, drag or place objects over cord.



WARNING! Do **NOT** operate scanner in an explosive environment. Do **NOT** operate scanner in the presence of volatile substances.



WARNING! **MAGNETIC MATERIAL.** The handheld controller produces a strong magnetic field which may cause failure or permanent damage to items such as watches, memory devices, CRT monitors, medical devices or other electronics.



People with pacemakers or ICD's must stay at least 25 cm (10 in) away.



WARNING! LASER RADIATION. The optical guide contains a Class 1M laser. Do not view directly with optical instruments.



WARNING! If this product is to be used with any Child Products listed in (*Chaper 2.3*), be sure to read and comply with the warnings, instructions, and specifications in the Child Product's User Manual(s).



WARNING! DO NOT DISASSEMBLE. No user-serviceable parts. Disassembling any of the components in this product, beyond the instructions in this user manual, could void the regulatory certifications and/or effect the safety of the product.



CAUTION! Pinch points exist with this product. Keep fingers and hands clear of pinch points.



CAUTION! Do **NOT** operate the **MOTIX** crawler on an inspection surface which is electrically connected to a component that is being welded.



CAUTION! DO NOT DISCONNECT UNDER LOAD. Shut off power before connecting or disconnecting. Permanent damage to electronics could occur.



EMERGENCY STOP. This symbol indicates emergency stop button.



The **WEEE** symbol indicates that the product must not be disposed of as unsorted municipal waste, but should be collected separately.

(see "Disposal" on page 111 for additional details)

TABLE OF CONTENTS

1	Identification	1
1.1.	Product Brand	1
1.2.	Manufacturer	1
1.3.	Compliance Declarations	1
1.3.1.	ISED Emissions Compliance (Canada).....	1
1.3.2.	FCC Suppliers Declaration of Conformity (United States).....	1
1.3.3.	European Union CE Declarations	2
1.3.4.	UKCA Declarations	2
2	Product Specifications	3
2.1.	Base MOTIX System.....	3
2.1.1.	Intended Use	3
2.1.1.1.	Operating Limits	3
2.1.1.2.	Operating Environment.....	4
2.1.1.3.	User.....	4
2.1.2.	Unintended Use.....	4
2.1.3.	Dimensions and Weight	4
2.1.4.	Power Requirements.....	5
2.1.5.	Environmental Sealing	5
2.1.6.	Performance Specifications	6
2.1.7.	Encoder Interface Specifications	6
2.2.	Compatible Components Specifications	7
2.2.1.	Preamp Bracket	7
2.2.1.1.	Intended Use	7
2.2.1.2.	Operating Limits	7
2.3.	Child Products Specifications	8
2.3.1.	Motorized Couplant Pump	8
2.3.2.	Motorized Raster Arm	8
2.3.3.	Optical Guide	8
2.3.4.	Battery Kit	8

Definitions	9
3.1. Definition of Symbols	9
3.2. Safety Symbols	9
3.3. Safety Signal Words	10

System Components	11
4.1. Component Identification	11
4.1.1. Base System	11
4.1.2. Compatible Components	13
4.1.3. Child Products	14
4.2. Tools	15
4.2.1. Included Tools	15
4.2.2. Optional Tools	15
4.3. Base System Components	16
4.3.1. Crawler	16
4.3.1.1 Encoder	16
4.3.1.2 Connections	17
4.3.1.3 Emergency Stop Button	17
4.3.2. Power Controller	18
4.3.2.1 AC/DC Power Supply	19
4.3.3. Umbilical	20
4.3.3.1 Encoder Signal Isolation	20
4.3.4. Handheld Controller	21
4.3.5. Auxiliary Cable	22
4.3.6. J300 Encoder Cable	22
4.3.7. Chain Link	22
4.3.8. Dovetail Link	22
4.3.9. Standard Overtop Link	23
4.3.10. Large Overtop Link	23
4.3.11. Buckle	23
4.3.12. Irrigation Kit	23
4.3.13. Cable Management	23
4.3.14. Tools	24
4.3.15. Cases	24
4.4. Compatible Components	25
4.4.1. Frame Bar	25
4.4.2. Slip Joint Probe Holder	25
4.4.3. Vertical Probe Holder	25
4.4.4. Heavy Duty Vertical Probe Holder	25
4.4.5. HydroFORM Cart	25
4.4.6. Preamp Bracket	26

4.4.7.	Battery Powered Optical Guide	26
4.4.8.	Encoder Adapter	26
4.5.	Child Products	27
4.5.1.	Motorized Couplant Pump	27
4.5.2.	Motorized Raster Arm	27
4.5.3.	Optical Guide	27
4.5.4.	Battery	27

5

Preparation for Use 28

5.1.	System Connectivity	28
5.2.	Configurations	30
5.2.1.	Two or Four Probe Cantilever	30
5.2.2.	Two Probe	32
5.3.	Crawler	34
5.3.1.	Swivel Mount	34
5.3.1.1.	Mounting components	34
5.3.1.2.	Align Swivel Mount	35
5.3.2.	Handle	36
5.3.3.	Emergency Off Button	36
5.3.4.	Umbilical	37
5.3.5.	Cable Retainer	37
5.4.	Handheld Controller	38
5.4.1.	Magnetic Mounts	38
5.5.	Chain Connections	39
5.5.1.	Large Overtop Link	39
5.5.2.	Standard Overtop Link	39
5.5.3.	Connecting Chain Links with Buttons	39
5.5.4.	Disconnecting Chain Links with Top Button	40
5.5.5.	Disconnecting Dovetail Link	40
5.5.6.	Connecting Overtop Links with Pins	41
5.6.	Probe Holders	42
5.6.1.	Vertical Probe Holder	42
5.6.1.1.	Probe Holder Setup	42
5.6.1.2.	Probe Holder Vertical Adjustment	43
5.6.1.3.	Probe Holder Transverse Adjustment	44
5.6.1.4.	Probe Holder Longitudinal Adjustment	45
5.6.1.5.	Probe Holder Left/Right Conversion	46
5.6.2.	Slip Joint Probe Holder	48
5.6.2.1.	Probe Holder Setup	48
5.6.2.2.	Probe Holder Adjustment	50
5.6.2.3.	Probe Holder Force Adjustment	51
5.6.2.4.	Slip Joint Probe Holder Left/Right Conversion	53

5.6.3.	Heavy Duty Vertical Probe Holder	55
5.6.3.1	Probe Holder Setup	55
5.6.3.2	Probe Holder Vertical Adjustment.....	57
5.6.3.3	Probe Holder Left/Right Conversion	57
5.6.4.	Cable Clips.....	59
5.7.	Battery Powered Optical Guide	60
5.8.	Cable Management	62
5.8.1.	Cable Management Dovetail Mount	62
5.8.2.	Cable Management Setup	63
5.8.3.	Clamp Setup	64
5.9.	Preamp Bracket	65
5.9.1.	Mounting Preamp Bracket	65
5.9.2.	Attaching Preamp with Screws	65
5.9.3.	Attaching Preamp with Velcro Straps	66

6

Operation 67

6.1.	Setup of MOTIX on a Scanning Surface	67
6.2.	System Startup	72
6.3.	Operation.....	74
6.3.1.	Handheld Controller Layout	74
6.3.1.1	Touchscreen	74
6.3.1.2	D-pad	74
6.3.1.3	Joysticks	75
6.3.2.	Mode Select Screen	76
6.3.3.	Jog Mode	76
6.3.4.	Latched Jog Mode	78
6.3.5.	1 Axis Scan Mode	79
6.3.5.1	1 Axis Scan Screen	80
6.3.6.	System Utilities Screen	82
6.3.6.1	User Settings Screen	83
6.3.6.2	Diagnostics Screens	84
6.3.6.2.1	Detected Modules	84
6.3.6.2.2	System 1	84
6.3.6.2.3	System 2	85
6.3.6.2.4	System 3	85
6.3.6.2.5	Motix	86
6.3.6.3	Touch Calibration Screen	87
6.3.6.4	Joystick Calibration Screen	88
6.3.6.5	Draw	89
6.3.7.	High Internal Temperature Screen	89

7

Maintenance..... 91

7.1.	Safety Precautions Before Maintenance	91
7.2.	Cleaning.....	91
7.3.	Maintenance Schedule	92

8	Troubleshooting	93
8.1.	Startup Issues	93
8.1.1.	Joystick Off Center	93
8.1.2.	Checking Network	93
8.2.	Startup Override	94
8.2.1.	Scan Devices	95
8.2.2.	Reset Parameters	96
8.2.3.	System Parameters	96
8.2.4.	Device Address.....	96
8.3.	Additional Issues	97

9	Service and Repair	98
9.1.	Technical Support	98

10	Spare Parts	99
10.1.	Crawler	99
10.2.	Kit Components	100
10.2.1.	Encoder Connector Type	102
10.2.2.	Power Cord Type	102
10.2.3.	Cable Management, Dovetail Mount	103
10.2.4.	Cable Management Sleeving	103
10.3.	Slip Joint Probe Holder Parts	104
10.4.	Vertical Probe Holder Parts	105
10.5.	Heavy Duty Vertical Probe Holder	106
10.5.1.	Probe Holder Components	107
10.5.2.	Arm Style	107
10.5.3.	Yoke Style	107
10.5.4.	Swing Arm Style	107
10.5.5.	Heavy Duty Yoke Style	107
10.5.6.	Pivot Button Style	108
10.6.	Variable Components	108
10.6.1.	Frame Bar	108
10.7.	Accessories.....	109
10.7.1.	Preamp Bracket	109
10.7.2.	Battery Powered Optical Guide	109
10.8.	Cases.....	110

11	Disposal	111
12	Limited Warranty	112
13	Appendix	114
	13.1. MOTIX Setup Chart	114

IDENTIFICATION

1.1. Product Brand

This user manual describes the proper safety precautions, setup and use of the **MOTIX** system.

1.2. Manufacturer

Distributor:

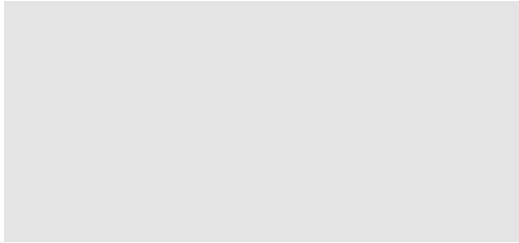

Manufacturer:

Jireh Industries Ltd.
53158 Range Road 224
Ardrossan, Alberta, Canada
T8E 2K4
Phone: 780.922.4534
jireh.com

1.3. Compliance Declarations

1.3.1. ISED Emissions Compliance (Canada)

CAN ICES-003(A) / NMB-003(A)

This Class A digital apparatus complies with Canadian ICES-003.

Cet appareil numérique de la classe A est conforme à la norme NMB-003 du Canada.

1.3.2. FCC Suppliers Declaration of Conformity (United States)

This device complies with Part 15 of the FCC Rules. Operation is subject to the following two conditions: (1) this device may not cause harmful interference, and (2) this device must accept any interference received, including interference that may cause undesired operation.

This equipment has been tested and found to comply with the limits for a Class A digital device, pursuant to part 15 of the FCC Rules. These limits are designed to provide reasonable protection against harmful interference when the equipment is operated in a commercial environment. This equipment generates, uses, and can radiate radio frequency energy and, if not installed and used in accordance with the instruction manual, may cause harmful interference to radio communications. Operation of this equipment in a residential area is likely to cause harmful interference in which case the user will be required to correct the interference at his own expense.

RESPONSIBLE PARTY NAME:	Jireh Industries
ADDRESS:	2955 S Sam Houston Pkwy E Suite 300 Houston, Texas United States 77047
TELEPHONE:	832-564-0626

1.3.3. European Union CE Declarations

Jireh Industries hereby declares that the MOTIX product complies with the essential requirements and other relevant provisions of the following European Union directives:



- 2014/30/EU EMC Directive
- 2014/35/EU Low Voltage Directive
- 2012/19/EU Directive on Waste Electrical and Electronic Equipment
- 2011/65/EU Directive on Restriction of Hazardous Substances (RoHS)

1.3.4. UKCA Declarations

Jireh Industries hereby declares that the MOTIX product complies with the essential requirements and other relevant provisions of the following UK directives.



Title	Edition/Date of Issue
Electromagnetic Compatibility Regulations	2016
Electrical Equipment (Safety) Regulations	2016
Waste Electrical and Electronic Equipment Regulations	2013
Restriction of the Use of Certain Hazardous Substances in Electrical and Electronic Equipment Regulations	2012

PRODUCT SPECIFICATIONS

2.1. Base MOTIX System

This section outlines the product specifications of the base system. When the base system is used together with compatible components (*Chapter 2.2*) or child products (*Chapter 2.3*), the product specifications of the base system may be superseded. (see “*Compatible Components Specifications*” on page 7) and (see “*Child Products Specifications*” on page 8).

2.1.1. Intended Use

The **MOTIX**’s primary purpose is to perform inspections of ferrous and non-ferrous pipes by moving an inspection tool around the surface. It is intended for industrial use only.

2.1.1.1 Operating Limits

Category	Parameter	Specification
Inspection Surface	Minimum OD, external circumferential driving with raster arm & EJS014	203.2 mm (8 in)
	Minimum OD, external circumferential driving with dovetail bar & EJS013	152.4 mm (6 in)
	Maximum OD, external circumferential driving	1066.8 mm (42 in)
	Maximum surface temperature	50°C (122°F)
Scanner	Maximum umbilical length	30 m (100 ft)
	Maximum payload <i>(performance may vary with surface condition)</i>	9 kg (20 lb) <i>(Umbilical and attachments are considered payload)</i>
	Attachments	Restricted to those listed in compatible components or child products

2.1.1.2 Operating Environment

The MOTIX is for use in dry industrial environments having ambient temperatures shown below. It is **NOT** intended for use in explosive environments.

Category	Parameter	Specification
Environment	Minimum ambient temperature	-20°C (-4°F)
	Maximum ambient temperature	50°C (122°F)

2.1.1.3 User

The MOTIX is intended to be used by persons who have read and understand the user manual. The intended user is to be a person without limitations in the physical abilities of the upper and lower limbs, sight, or hearing.

2.1.2. Unintended Use

The MOTIX is NOT intended for:

- ▶ use outside of its intended use
- ▶ driving into/over obstructions, excluding standard weld caps

2.1.3. Dimensions and Weight

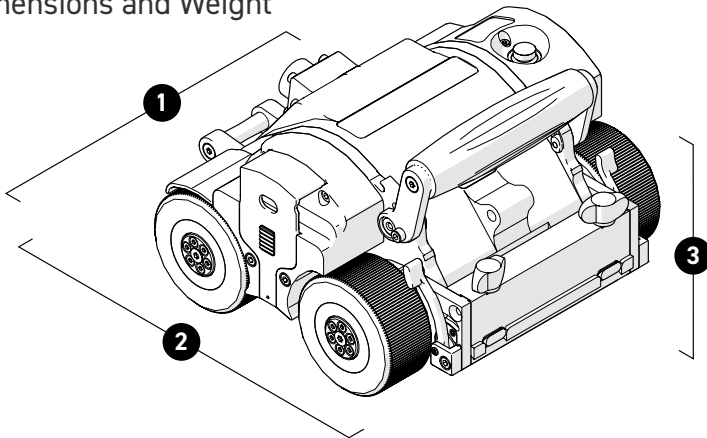

Fig. 1 - Dimensions

1	Crawler width:	20.6 cm	8.1 in
2	Crawler depth:	23.8 cm	9.4 in
3	Crawler height:	14 cm	5.5 in
	Crawler weight:	4.634 kg	10.22 lb

2.1.4. Power Requirements



WARNING! A reliable power source must be used to power the crawler. Connections must be secured to prevent accidental disconnection. Power failure may cause the crawler to freewheel down when operating in a vertical orientation. Portable generator usage is not recommended unless accompanied by the use of an uninterruptible power supply.



WARNING! Proper grounding of the power supply is important for safe operation. When a generator is used to supply power to the system (*not recommended*), the generator must be properly grounded (*refer to generator manual*).



CAUTION! DO NOT DISCONNECT UNDER LOAD. Shut off power before connection or disconnecting. Permanent damage to electronics could occur.



CAUTION! Power must be supplied from an approved Jireh power source.

Input Voltage:	25-45VDC
----------------	----------

Input Power:	320 W
--------------	-------

2.1.5. Environmental Sealing

Dust-tight, watertight (*not submersible*).

2.1.6. Performance Specifications

Category	Parameter	Specification
Crawler	Maximum speed	14.2 cm/sec (5.6 in/sec)
	Encoder resolution	220.4 counts/mm (5,598.4 counts/in)

2.1.7. Encoder Interface Specifications

Output type: 4 channel quadrature 5VDC RS422 compatible.

Power: Power must be supplied to the interface.

5VDC +/-10% power limited to < 15w.

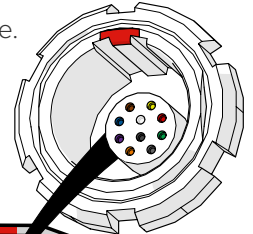

1	Enc B
2	Enc B'
3	Enc A
4	Enc A'
5	Aux Enc A'
6	Aux Enc A
7	Aux Enc B'
8	Aux Enc B
9	Enc +5V
10	Enc Com
H	Shield

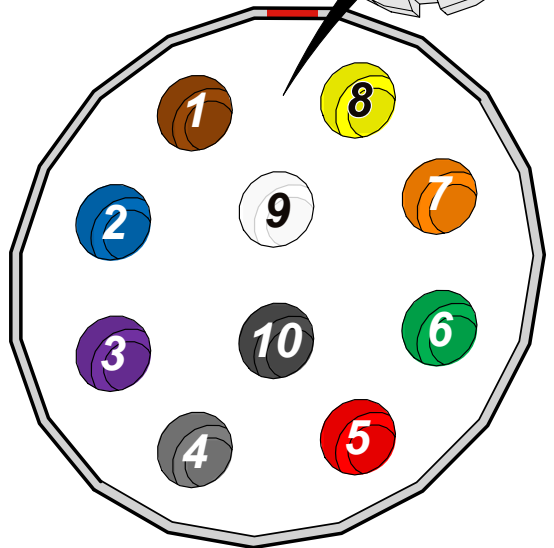

Fig. 2 - JIREH Industries pin out configuration

2.2. Compatible Components Specifications

The components listed do modify the product specifications (*i.e. intended use, power requirements, etc.*) from those of the base system. The specifications listed here supersede those of the base system.

2.2.1. Preamp Bracket CES029-

2.2.1.1 Intended Use

The Preamp Bracket is intended to mount objects such as preamps, splitters, etc. on a rack or dovetail bar that is mounted to the MOTIX crawler. The mounted object is attached to the MOTIX with a lanyard or probe cables strong enough to prevent the object from falling, should the straps or screws that hold it to the bracket fail. Also, if the object is mounted with straps, it is to have smooth edges so as not to cut the straps.

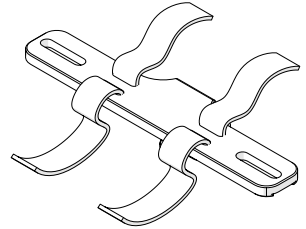

Fig. 3 - Preamp bracket

2.2.1.2 Operating Limits

Category	Parameter	Specification
Preamp bracket	Maximum weight of mounted object	1.36 kg (3 lb)

2.3. Child Products Specifications

The products listed in this section integrate with the MOTIX to perform certain tasks. Their use modifies the product specifications (*i.e. intended use, power requirements, etc.*) from those of the MOTIX. These products have a User Manual of their own, which should also be referred to for their product specifications.

2.3.1. Motorized Couplant Pump CMA015

The Motorized Couplant Pump is a powered pumping unit that supplies couplant fluid to scanning equipment.

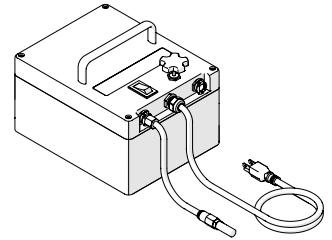

Fig. 4 - Motorized couplant pump

2.3.2. Motorized Raster Arm CWG002-

Available in various lengths, the Motorized Raster Arm can carry many different probes for various types of corrosion scans. The Motorized Raster Arm is intended to be mounted in the MOTIX's swivel mount.

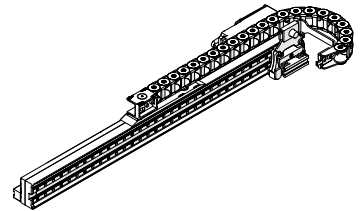

Fig. 5 - Motorized raster arm

2.3.3. Optical Guide CXG035

The Optical Guide mount's to any dovetail attached to a motorized crawler. The Optical Guide provides a green colour, point of reference for guiding scanners along a given path (*i.e. a weld*).

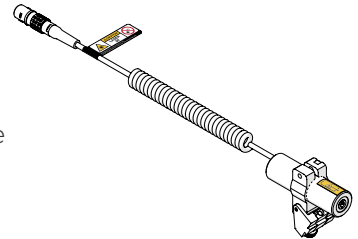

Fig. 6 - Optical guide

2.3.4. Battery Kit DVG001-

The battery provides portable power to the crawler.

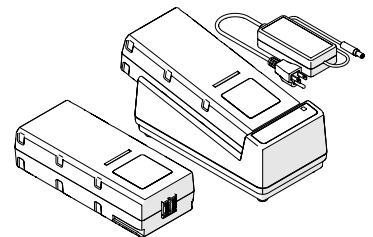

Fig. 7 - Battery kit

DEFINITIONS

3.1. Definition of Symbols



Instructions to 'look here' or to 'see this part'.

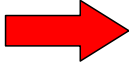

Denotes movement. Instructing user to carry out an action in a specified direction.

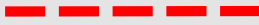

Indicates alignment axis.



Alerts the user that the view has changed to a reverse angle.

3.2. Safety Symbols

The following safety symbols might appear on the product and in this document. Read and understand their meaning below:



General warning symbol

This symbol is used to alert the user to potential hazards. All safety messages that follow this symbol shall be obeyed to avoid possible harm or material damage.



Shock hazard caution symbol

This symbol is used to alert the user to potential electric shock hazards. All safety messages that follow this symbol shall be obeyed to avoid possible harm.



Laser warning symbol

This symbol is used to alert the user to potential laser hazards. All safety messages that follow this symbol shall be obeyed to avoid possible harm or material damage.

3.3. Safety Signal Words

The following safety signal words might appear in this document. Read and understand their meaning below:

DANGER!

The DANGER signal word indicates an imminently hazardous situation. It calls attention to a procedure, practice, or the like that if not correctly performed or adhered to will result in death or serious personal injury. Do not proceed beyond a DANGER signal word until the indicated conditions are fully understood and met.

WARNING!

The WARNING signal word indicates a potentially hazardous situation. It calls attention to a procedure, practice, or the like that if not correctly performed or adhered to could result in death or serious personal injury. Do not proceed beyond a WARNING signal word until the indicated conditions are fully understood and met.

CAUTION!

The CAUTION signal word indicates a potentially hazardous situation. It calls attention to a procedure, practice, or the like that if not correctly performed or adhered to may result in minor or moderate personal injury, material damage, particularly to the product, destruction of part or all of the product, or loss of data. Do not proceed beyond a CAUTION signal word until the indicated conditions are fully understood and met.

SYSTEM COMPONENTS

4.1. Component Identification

4.1.1. Base System

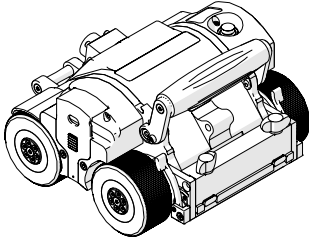

Fig. 8 - MOTIX (crawler)
EJA003

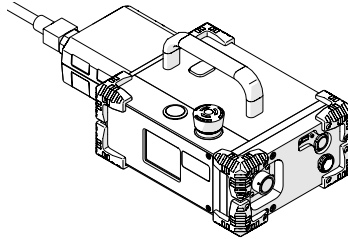

Fig. 9 - Power controller
CXA040-

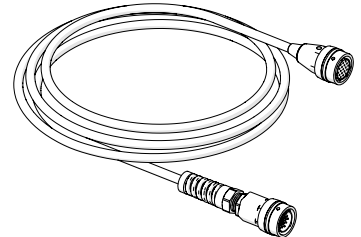

Fig. 10 - Umbilical
UMA022-

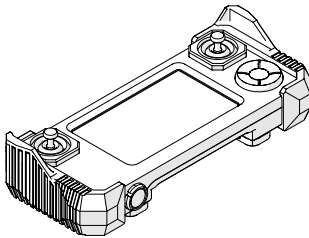

Fig. 11 - Handheld controller
DMA006

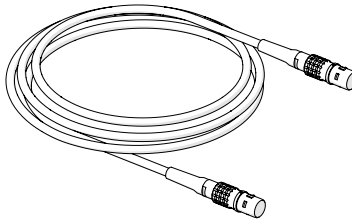

Fig. 12 - Auxiliary cable
UMA017-06

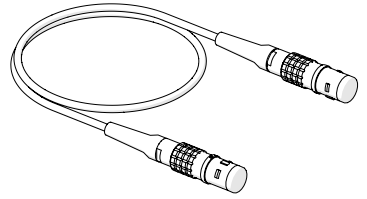

Fig. 13 - Encoder cable
UMA025-

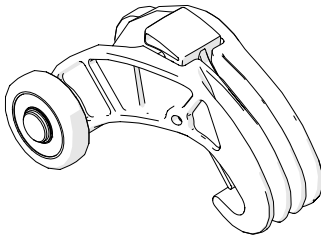

Fig. 14 - QuickLink
EES004

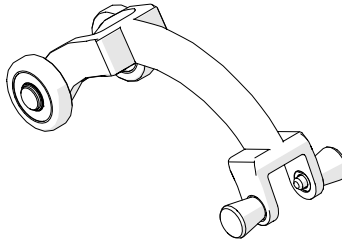

Fig. 15 - Standard overtop link
EJS013

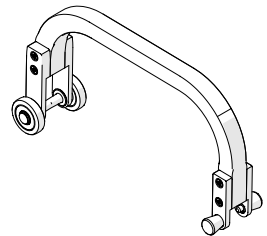

Fig. 16 - Large overtop link
EJS014

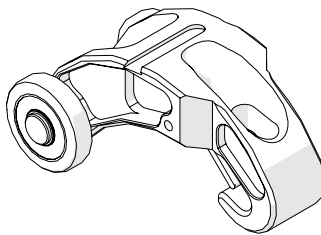

Fig. 17 - Dovetail QuickLink
EES011

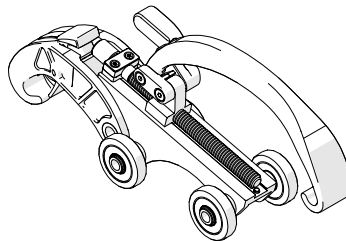

Fig. 18 - QuickLink buckle
EES014

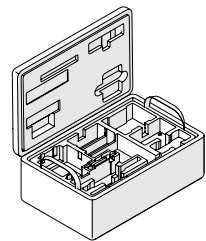

Fig. 19 - MOTIX case
EJA004

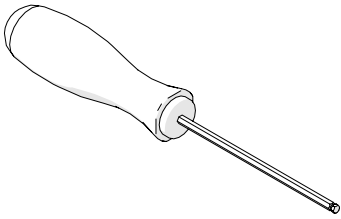

Fig. 20 - 3 mm hex driver
EA414

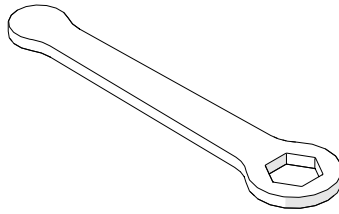

Fig. 21 - 3/8 in wrench
EA470

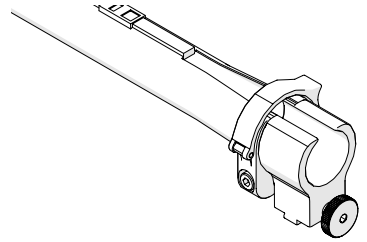

Fig. 22 - Cable management
CES044-

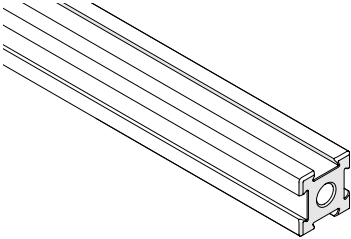

Fig. 23 - Frame bar
BG0038-

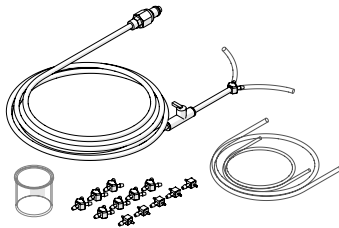

Fig. 24 - Irrigation Kit
CMG009-

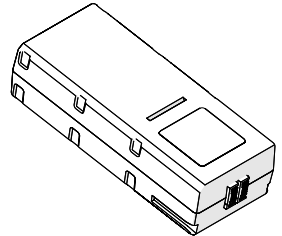

Fig. 25 - Battery
DVA001

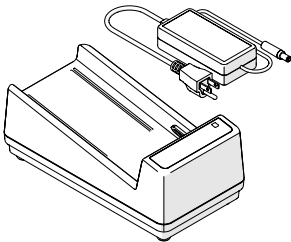

Fig. 26 - Charger and power adapter
DVG002-

4.1.2. Compatible Components

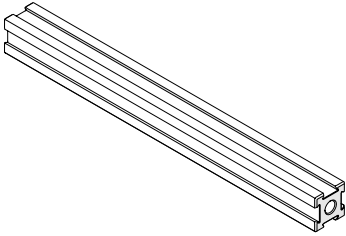

Fig. 27 - Frame bar
BG0038-

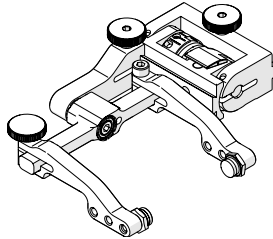

Fig. 28 - Slip joint probe holder
PHA012-

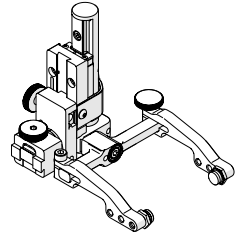

Fig. 29 - Vertical probe holder
PHA015-

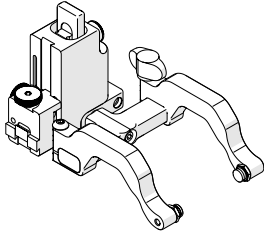

Fig. 30 - Heavy duty vertical probe holder
PHS043-

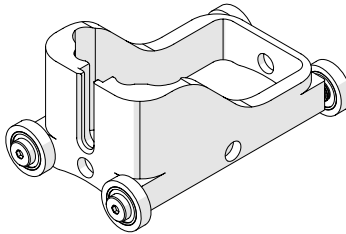

Fig. 31 - HydroFORM cart
PHS044

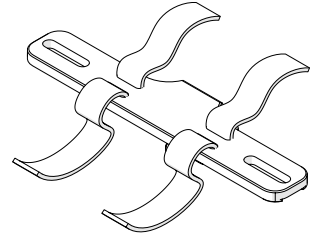

Fig. 32 - Preamp bracket
CES029-

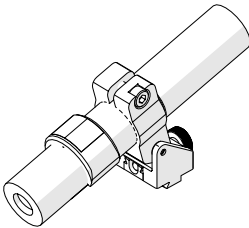

Fig. 33 - Battery powered optical guide
CXS080

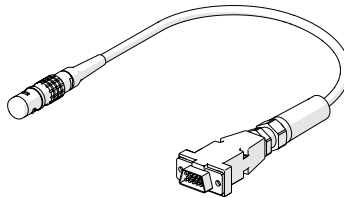

Fig. 34 - Encoder adapter
UMA010-

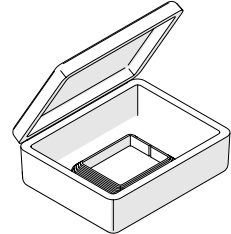

Fig. 35 - Motorized pump / umbilical case
CMA016

4.1.3. Child Products

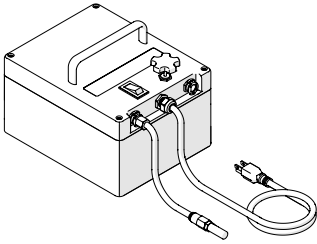

Fig. 36 - Motorized Couplant Pump
CMA015

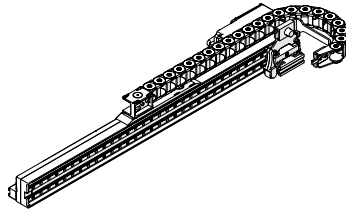

Fig. 37 - Motorized raster arm
CWG002-

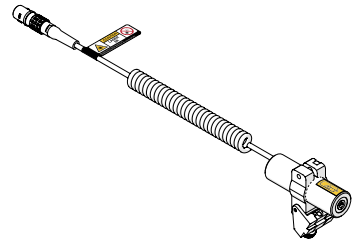

Fig. 38 - Optical guide
CXG035

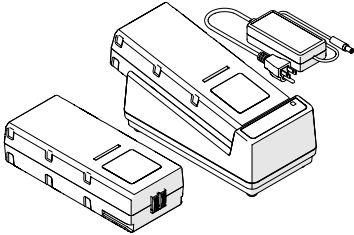

Fig. 39 - Battery Kit
DVG001-

4.2. Tools

4.2.1. Included Tools

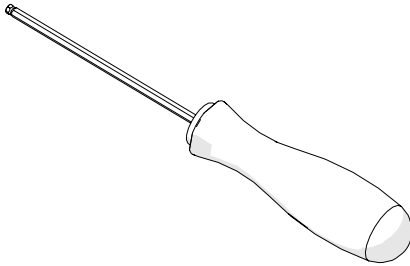

Fig. 40 - 3 mm hex driver

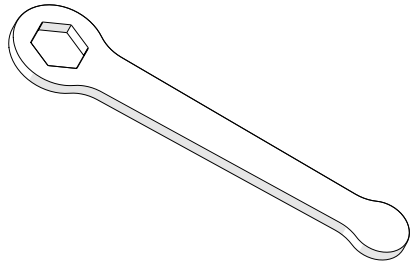

Fig. 41 - 3/8 in wrench

The included 3 mm hex driver (*Fig. 40*) is suitable for most typical adjustments within the **MOTIX** system.

Also included in this kit is a 3/8 in wrench (*Fig. 41*) which is used to remove and install probe holder pivot buttons.

4.2.2. Optional Tools

Some specialized adjustments require tools that are not included in this kit.

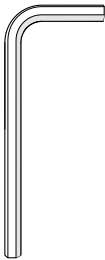

Fig. 42 - 1.5 mm hex wrench

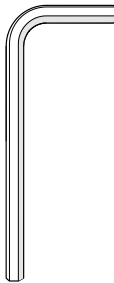

Fig. 43 - 2 mm hex wrench

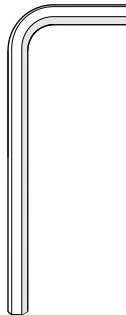

Fig. 44 - 3 mm hex wrench

4.3. Base System Components

4.3.1. Crawler

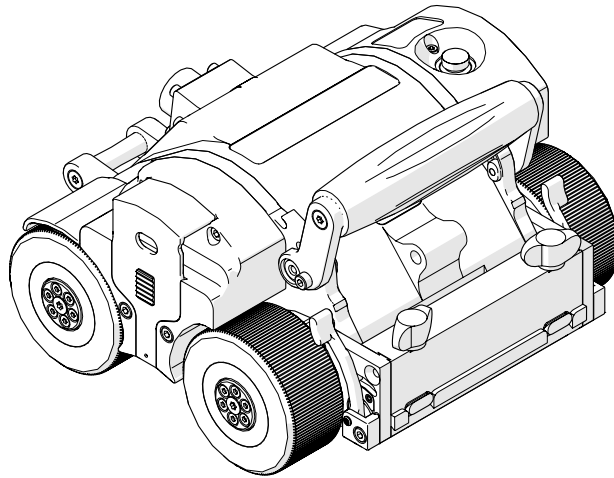

Fig. 45 - MOTIX crawler

The crawler provides the means for motorized travel. A handle is provided for convenience

4.3.1.1 Encoder

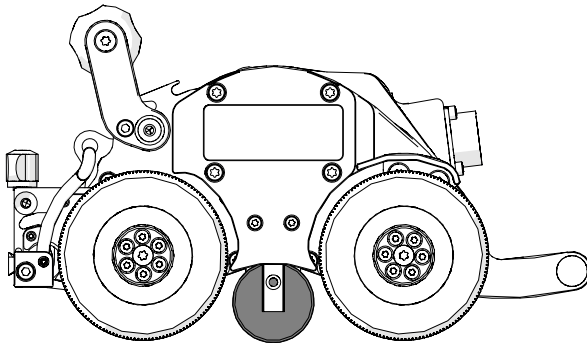

Fig. 46 - Encoder wheel

The crawler includes an independent encoder wheel. This encoder wheel provides accurate encoding even in the event of drive wheel slip.

The spring-loaded encoder wheel maintains scan surface contact through all listed scan diameter sizes

(see "Operating Limits" on page 3). Adjustment of the encoder wheel is not required.

4.3.1.2 Connections

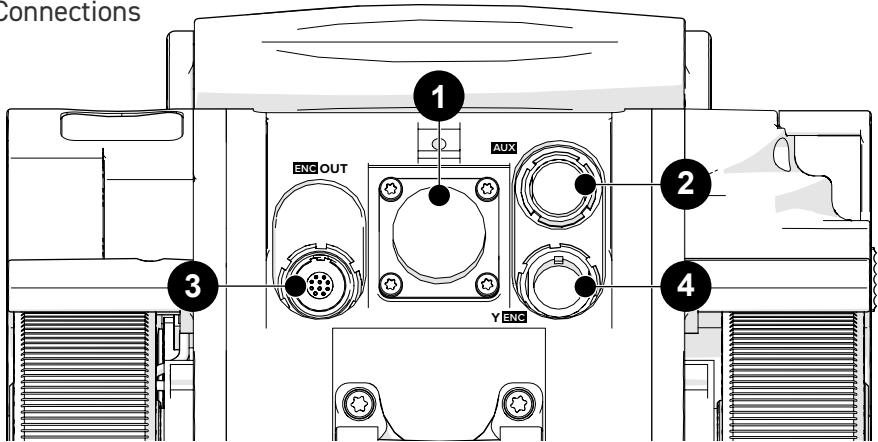

Fig. 47 - Crawler connections

1	Umbilical connection	Connection for the umbilical.
2	AUX	Connection for an auxiliary device.
3	ENC OUT	Encoder output connection.
4	Y ENC	Connection for a 2 nd encoder axis input or motorized module connection. The device connected to the Y-ENC 8-pin has its encoder signals passed through as the 2nd encoder axis on the encoder output connectors.

4.3.1.3 Emergency Stop Button

The red button on the top of the crawler is an emergency off button to the entire system. When pressed, all power will disengage.

To restore system power, press the power button on the power controller (see “Power Controller” on page 18).



Fig. 48 - Emergency off

NOTE: Terminating system power may cause the crawler to freewheel around a pipe.

4.3.2. Power Controller



CAUTION! **DO NOT DISCONNECT UNDER LOAD.** Shut off power before connection or disconnecting. Permanent damage to electronics could occur.



WARNING! There are no user serviceable components inside the power controller. Dangerous voltages can be present inside the case. Do **NOT** open. Return to manufacturer for repair.

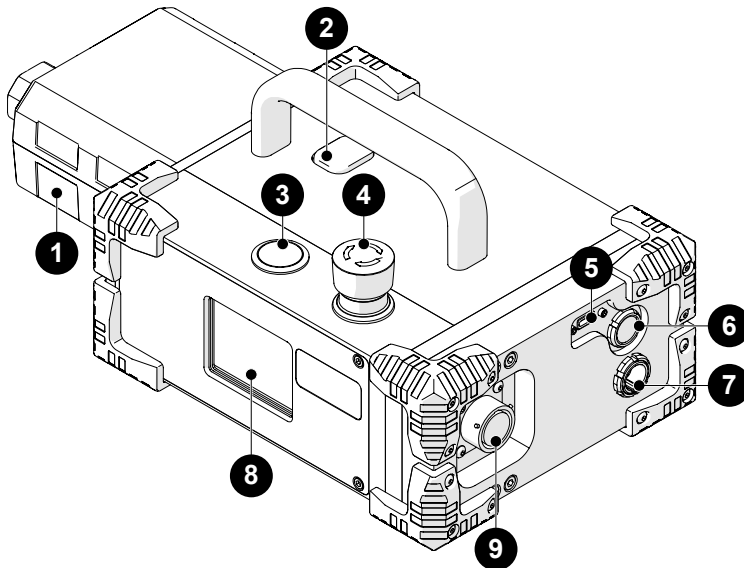

Fig. 49 - Power controller

The power controller accepts 25-45VDC power from the AC/DC power supply or battery. A start/stop safety circuit and physical **ON** and **OFF** push buttons are integrated into the power controller.

- | | | |
|----------|--------------------|---|
| 1 | AC/DC power supply | Connect plug from a properly grounded source.
Use IEC320 cord approved for AC/DC power supply. |
| 2 | Release button | Unlatch the AC/DC power supply or battery from the power controller. |
| 3 | Power button | Activate system power by pressing (and releasing) the silver button. |

4	Stop button	The red stop button latches down when pressed, this stop button shuts down the system. Twist the stop button clockwise to return to the released position. This must be done before power can be activated.
5	Scanlink™ connector	USB-C connection for Scanlink devices.
6	CTRL socket	Connection for the auxiliary cable.
7	ENC socket	Connection for the encoder cable.
8	Status LCD	Power controller status display.
9	Umbilical connection	Connection for the umbilical.

In the event of a break in the stop circuit (*the stop circuit runs through the power controller cable, umbilical and the crawler's emergency stop button*) power will shut off.

4.3.2.1 AC/DC Power Supply



WARNING! ELECTRICAL CORDS CAN BE HAZARDOUS. Misuse can result in **FIRE** or **DEATH** by **ELECTRICAL SHOCK**. Inspect thoroughly before each use. Do **NOT** use if damaged. Do **NOT** use when wet. Keep away from water. Do **NOT** drive, drag or place objects over cord.

The **1** AC/DC power supply (*Fig. 49*) is used to connect the power controller to a suitable 100-240VAC, 50/60Hz grounded power source capable of supplying a minimum of 5 amps.

The safety of the power controller relies on the provision of a proper ground connection.

In environments with moisture present, a GFCI (*Ground Fault Circuit Interrupter*) must be used to ensure operator safety.

NOTE: *Some generators or DC-AC inverters may introduce significant levels of noise to the system. This may degrade overall system performance or reduce the system life expectancy. Use of generators or DC-AC inverters is not recommended and are used at the operator's risk.*

4.3.3. Umbilical

The umbilical is the backbone of the system. It provides all power, network distribution as well as encoder signal transmission. Circuitry is incorporated into the umbilical to protect or isolate all signals. The umbilical provides separation between the power controller and the crawler. Various umbilical lengths are available.

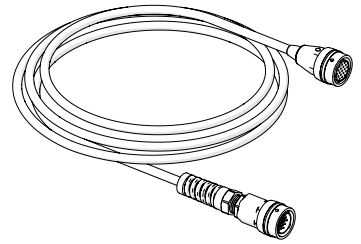

Fig. 50 - Umbilical

4.3.3.1 Encoder Signal Isolation

The umbilical contains a built-in circuit which buffers encoder signals in addition to providing isolation and protection to user instrumentation. The isolator requires 5VDC from the user's instrument and this is built into the supplied encoder cables.

4.3.4. Handheld Controller



WARNING! MAGNETIC MATERIAL. The handheld controller contains magnetic material. Those with pacemakers or ICD's must stay at least 10 cm (4 in) away.



CAUTION! DO NOT DISCONNECT UNDER LOAD. Shut off power before connection or disconnecting. Permanent damage to electronics could occur.

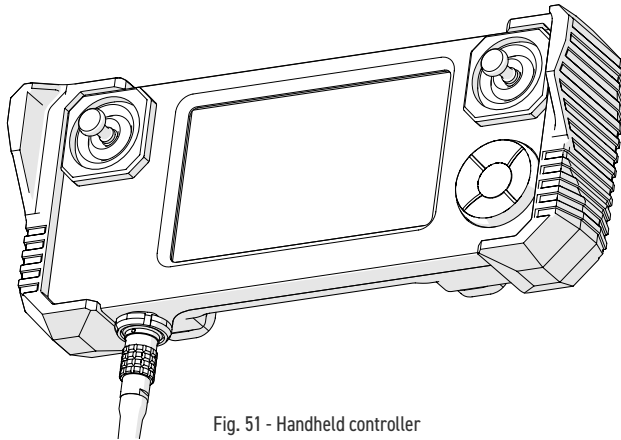

Fig. 51 - Handheld controller

The handheld controller is used to manipulate a scanner installed on an inspection surface. User settings and scan information are edited using the handheld controller. The handheld controller is connected to the power controller or umbilical with the auxiliary cable.

The handheld controller utilizes a resistive touch screen, care should be taken to not use sharp or gritty objects on the screen as the touch membrane can scratch. If the screen is damaged, all programmed functions can still be accessed using the D-pad.

NOTE: Do **NOT** connect the handheld controller while system activated.

4.3.5. Auxiliary Cable

The auxiliary cable connects the handheld controller to the power controller. 36VDC and network signals are used in the cable.

Both auxiliary cable connectors are identical and interchangeable. The cable may be plugged into the 4-pin receptacle on the power controller or the crawler's umbilical.

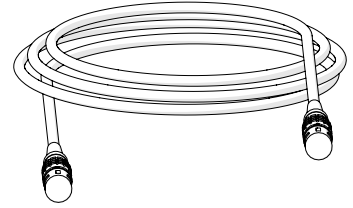

Fig. 52 - Auxiliary cable

4.3.6. J300 Encoder Cable

The encoder cable connects the **MOTIX** system to the user's instrument. This cable allows transmission of two-axis position signals from the **MOTIX** to the instrument. The encoder cable also provides 5VDC from the user's instrument to the encoder isolation circuitry.

Various encoder styles are available for various instruments.

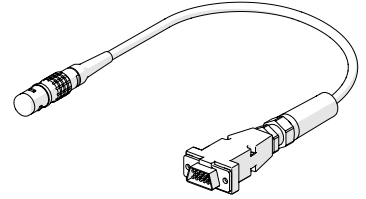

Fig. 53 - Encoder cable

4.3.7. Chain Link

The chain links connect to assemble the required length to mount the system to a pipe.

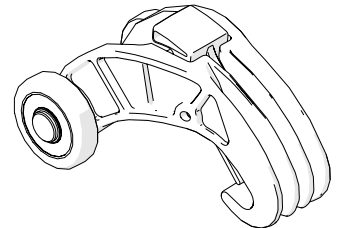

Fig. 54 - Chain link

4.3.8. Dovetail Link

The dovetail link provides a mounting point for the cable management.

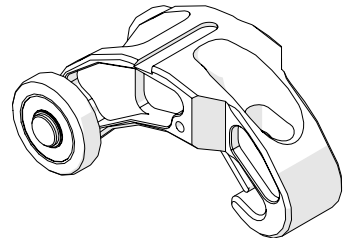

Fig. 55 - Dovetail link

4.3.9. Standard Overtop Link

The standard overtrop link attaches to the front of the **MOTIX** for use with cantilever configurations.

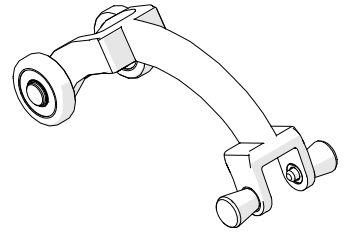

Fig. 56 - Standard overtrop link

4.3.10. Large Overtrop Link

The large overtrop link is designed for use with a motorized raster arm (*sold separately*) (see “*Motorized Raster Arm*” user manual) or when using a two probe configuration.

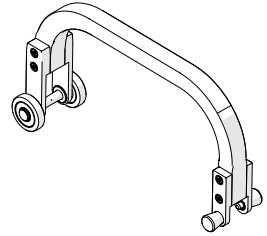

Fig. 57 - Large overtrop link

4.3.11. Buckle

The buckle offers adjustment of the chain link tension as well as provides the connection point of the chain assembly.

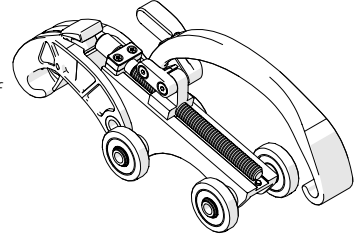

Fig. 58 - Buckle

4.3.12. Irrigation Kit

The irrigation kit provides a variety of hoses, fittings, connectors and splitters commonly used during non-destructive inspection.

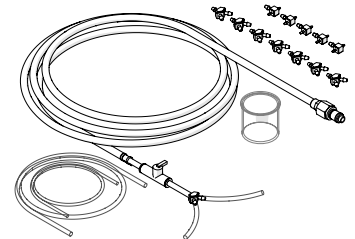

Fig. 59 - Irrigation kit

4.3.13. Cable Management

The cable management provides a means of protecting and organizing cables, tubes and hoses.

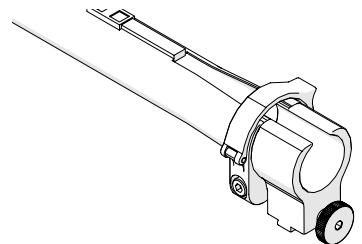

Fig. 60 - Cable management

4.3.14. Tools

Several tools are included for various scanner and accessory adjustments. (see *"Included Tools" on page 15 for additional details*)

4.3.15. Cases

Depending on the configuration selected at the time of purchase. This will determine the types and amount of cases included with the system.

4.4. Compatible Components

4.4.1. Frame Bar

Frame bars use dovetail grooves into which probe holders and accessories may be attached. Available in various lengths.

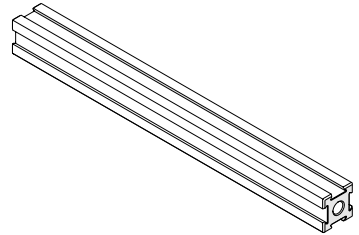

Fig. 61 - Frame bar

4.4.2. Slip Joint Probe Holder

The slip joint probe holder is generally used during limited access inspection. The low profile design requires minimal radial clearance. The slip joint probe holder is designed to carry many different types of probes and wedges, it is available with various types of yokes, arms and pivot buttons.

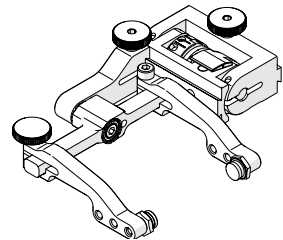

Fig. 62 - Slip joint probe holder

4.4.3. Vertical Probe Holder

The vertical probe holder is designed to carry many different types of probes and wedges. Available with various types of yokes, arms and pivot buttons. The vertical probe holder features several different adjustment options for each unique probe/wedge setup.

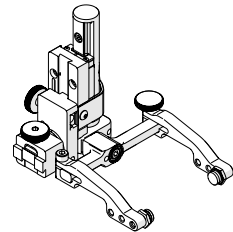

Fig. 63 - Vertical probe holder

4.4.4. Heavy Duty Vertical Probe Holder

The heavy duty vertical probe holder is designed to carry larger probes. Available with various arm, yoke and pivot buttons, the heavy duty vertical probe holder exerts more down force on a large footprint probe/wedge.

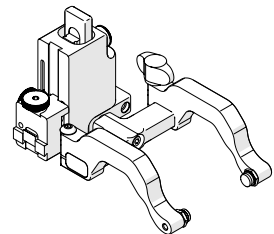

Fig. 64 - Heavy duty vertical probe holder

4.4.5. HydroFORM Cart

The HydroFORM Cart carries an Olympus HydroFORM™ probe. The HydroFORM cart is designed to be used in conjunction with the heavy duty vertical probe holder.

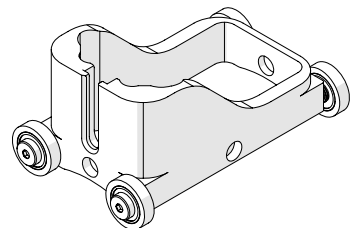

Fig. 65 - HydroFORM cart

4.4.6. Preamp Bracket

The preamp mounts to any dovetail groove. It is compatible with more standard preamps.

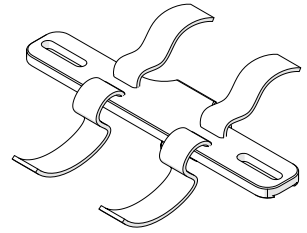

Fig. 66 - Preamp bracket

4.4.7. Battery Powered Optical Guide

The battery powered optical guide provides a red colour point of reference useful for guiding scanners along a given path (*i.e. a weld*).

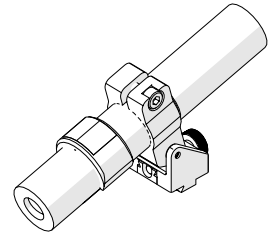

Fig. 67 - Battery powered optical guide

4.4.8. Encoder Adapter

The encoder adapter changes the scanner's built in encoder connector style.

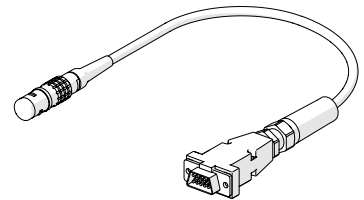

Fig. 68 - Encoder adapter

4.5. Child Products

4.5.1. Motorized Couplant Pump

The motorized couplant pump is a powered pumping unit used for supplying couplant fluid to the scanning surface.

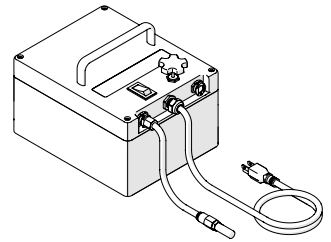

Fig. 69 - Motorized couplant pump

4.5.2. Motorized Raster Arm

The motorized raster arm is available in various lengths and offers programmable speed and travel settings.

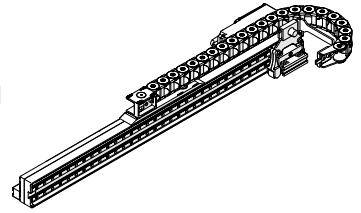

Fig. 70 - Motorized raster arm

4.5.3. Optical Guide

The optical guide mounts to any dovetail and provides a green colour point of reference useful for guiding scanners along a given path (*i.e. a weld*).

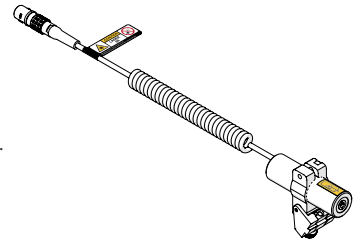

Fig. 71 - Optical guide

4.5.4. Battery

The rechargeable battery provides portable power to the crawler and components (*i.e. motorized raster arm*).

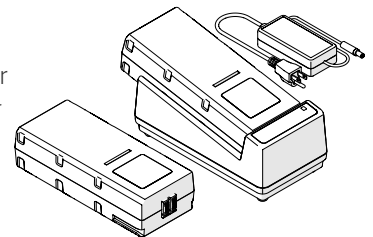

Fig. 72 - Battery

PREPARATION FOR USE

5.1. System Connectivity

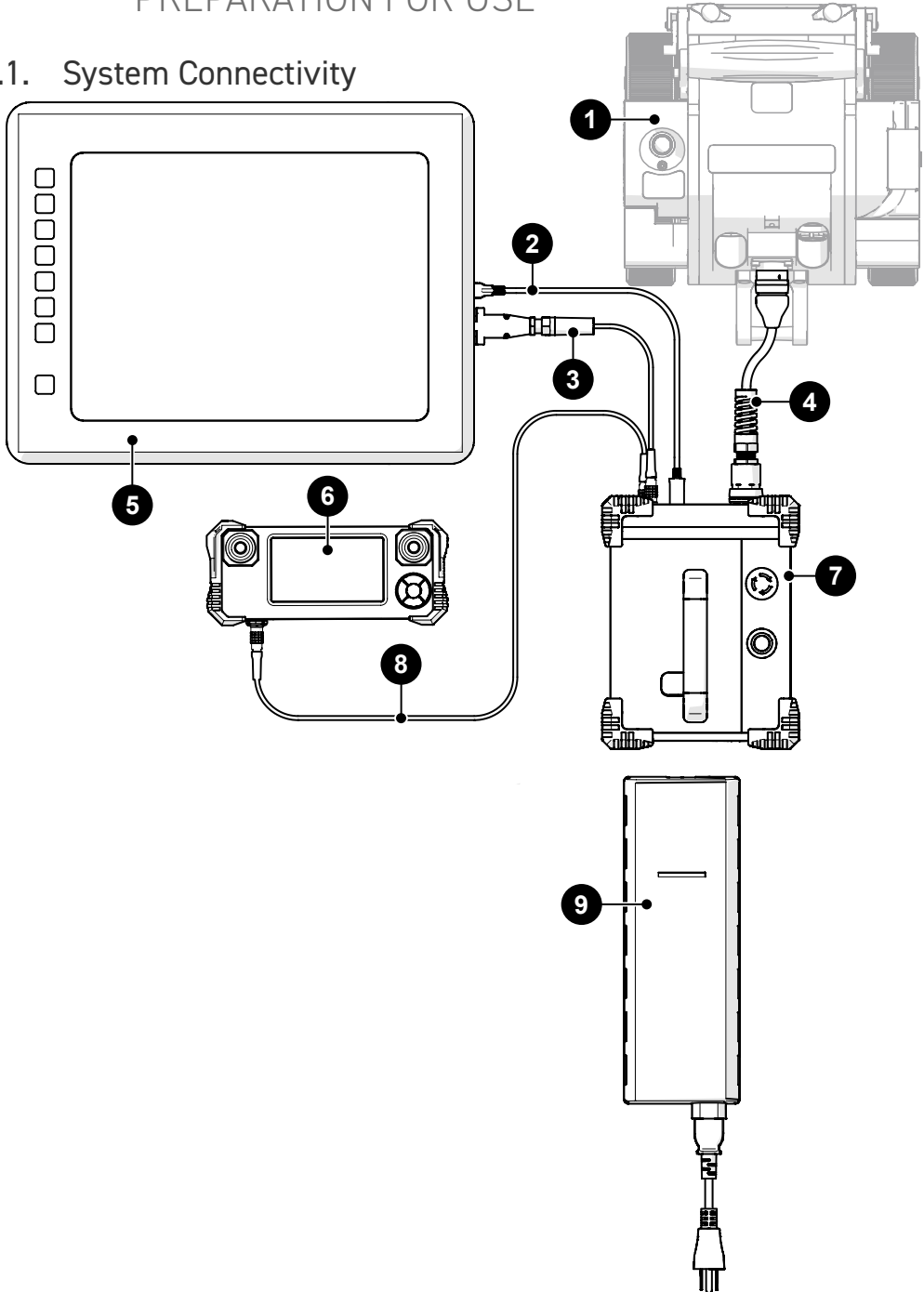

Fig. 73 - Standard crawler configuration

BOM ID	Description
1	MOTIX crawler
2	Scanlink™ cable
3	Encoder connector
4	Umbilical
5	User instrument
6	Handheld controller
7	Power controller
8	Auxiliary cable
9	AC/DC power supply

To configure the MOTIX system for scanning, follow these steps:



CAUTION! DO NOT DISCONNECT UNDER LOAD. Shut off power before connection or disconnecting. Permanent damage to electronics could occur.



1. Mount and connect the **4** umbilical to **1** the crawler.
2. Connect **4** umbilical to **7** power controller.
3. Connect **6** handheld controller to **7** power controller using the **8** auxiliary cable.
4. Connect **3** encoder cable from the **5** user's instrument to the **7** power controller.
5. Insert **9** AC/DC power supply into the **7** power controller.
6. (see "Configurations" on page 30) to set up a particular component.

5.2. Configurations

5.2.1. Two or Four Probe Cantilever

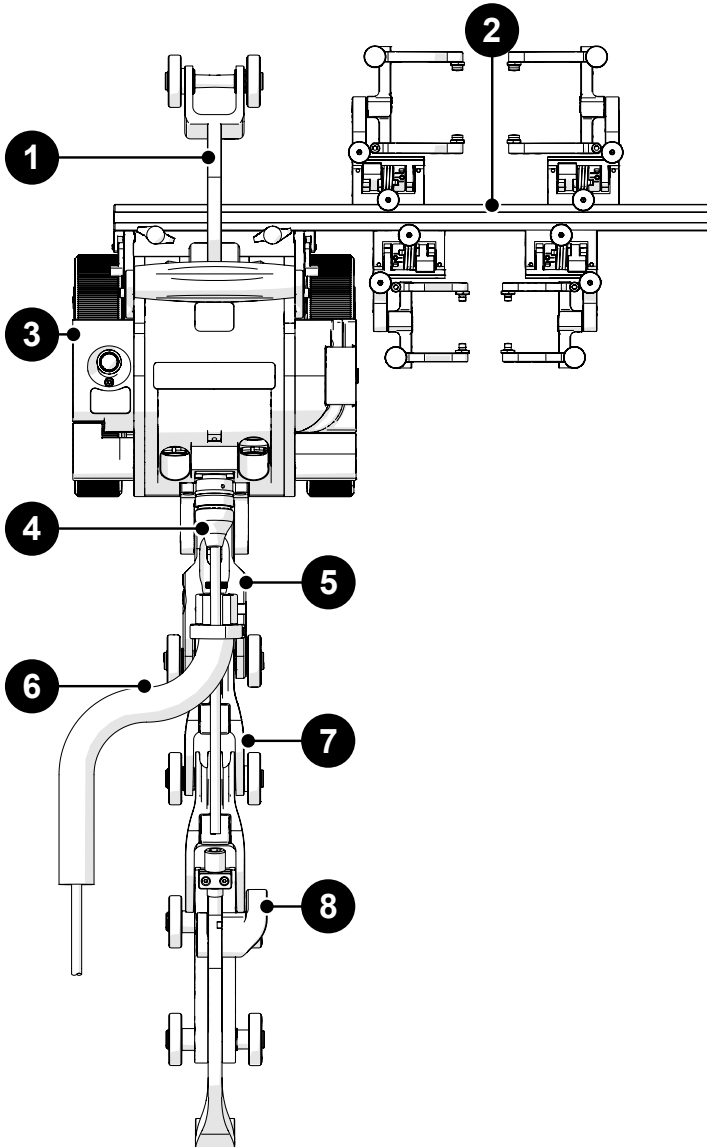

Fig. 74 - Two or four probe cantilever

BOM ID	Description
1	Standard overtop link
2	Probe holder frame
3	MOTIX crawler
4	Umbilical
5	Dovetail link
6	Cable management
7	Chain link
8	Buckle

To configure the **MOTIX** system for scanning, follow these steps:



CAUTION! DO NOT DISCONNECT UNDER LOAD. Shut off power before connection or disconnecting. Permanent damage to electronics could occur.



1. Mount and connect the **4** umbilical to the **3** crawler.
2. Route the **4** umbilical through the **6** cable management.
3. Attach the configured **2** frame bar and probe holders to the **3** crawler (see “Mounting components” on page 34).
4. Connect the appropriate **5** **7** links, **8** buckle and **1** standard overtop link (see “Chain Connections” on page 39).

5.2.2. Two Probe

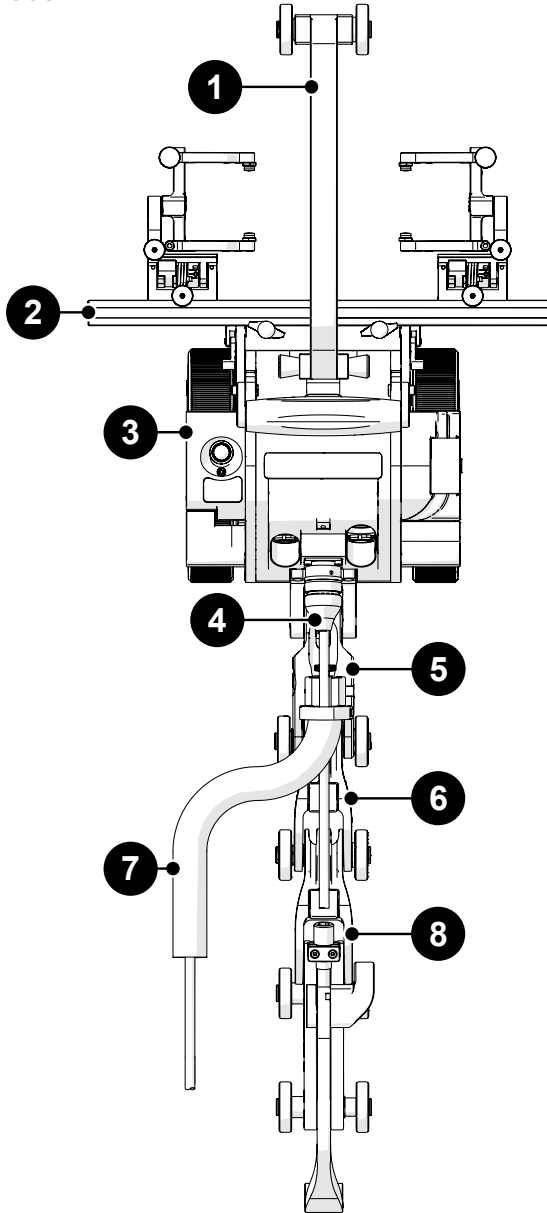

Fig. 75 - Two probe

BOM ID	Description
1	Short link
2	Large overtop link
3	Probe holder frame
4	MOTIX crawler
5	Umbilical
6	Dovetail link
7	Cable management
8	Buckle

To configure the **MOTIX** system for scanning, follow these steps:



CAUTION! DO NOT DISCONNECT UNDER LOAD. Shut off power before connection or disconnecting. Permanent damage to electronics could occur.

1. Mount and connect the **4** umbilical to the **2** crawler.
2. Route the **4** umbilical through the **7** cable management.
3. Attach the configured **2** frame bar and probe holders to the **3** crawler (see “Mounting components” on page 34).
4. Connect the appropriate **5** **6** links, **8** buckle, **1** Large overtop link (see “Chain Connections” on page 39).

5.3. Crawler

5.3.1. Swivel Mount

The swivel mount is located at the front of the crawler and is used to connect scanning components. The swivel mount is to be adjusted parallel with the scan surface.

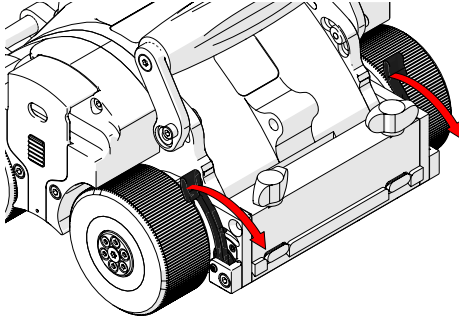

Fig. 76 - Unlock swivel mount

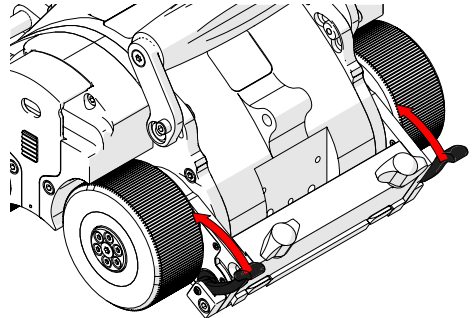

Fig. 77 - Lock swivel mount

The swivel mount utilizes two levers (*Fig. 76*) to unlock the swivel mount. Once the appropriate angle has been set, lock the two levers (*Fig. 77*).

5.3.1.1 Mounting components

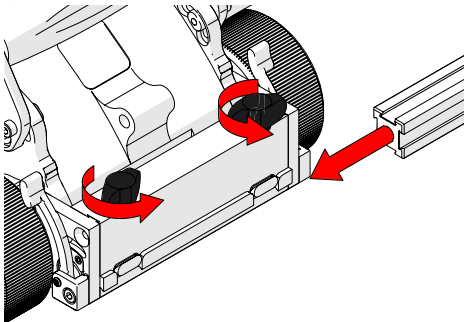

Fig. 78 - Frame bar installation

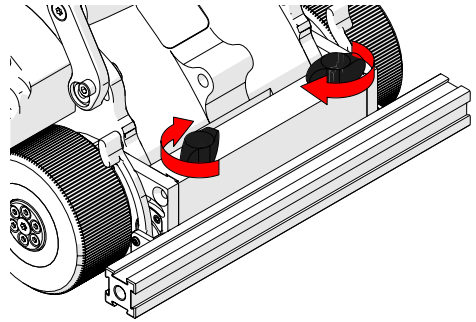

Fig. 79 - Tighten wing knobs

1. Rotate the two black wing knobs (*Fig. 78*) to loosen the dovetail jaws. Slide the frame bar along the dovetail jaws.
2. Once the frame bar placed appropriately, rotate the two black wing knobs to clamp the component in place (*Fig. 79*).

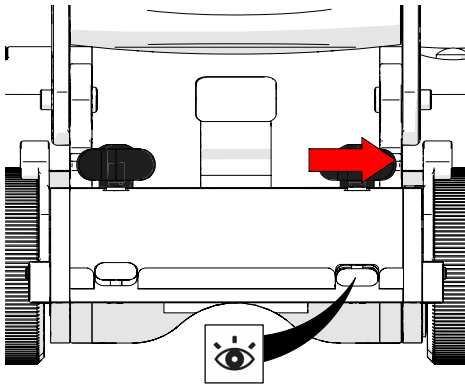

Fig. 80 - Lower dovetail jaws

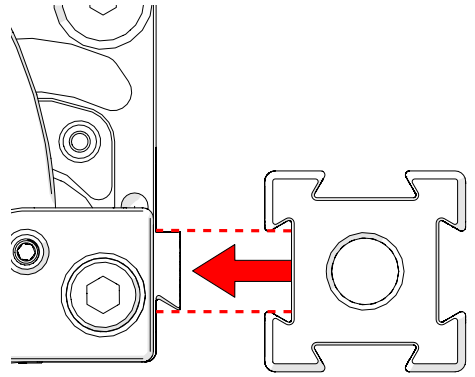

Fig. 81 - Mount frame bar

Alternatively, accessories can also be mounted straight to the swivel mount.

3. Rotate the black wing knobs aligning the dovetail jaws with the mount's grooves (Fig. 80).
4. Press the frame bar or accessory to the swivel mount (Fig. 81) and tighten the black wing knobs.

5.3.1.2 Align Swivel Mount

When required, it is possible to ensure a horizontal angle of the swivel mount using the etched line on the crawler (Fig. 82).

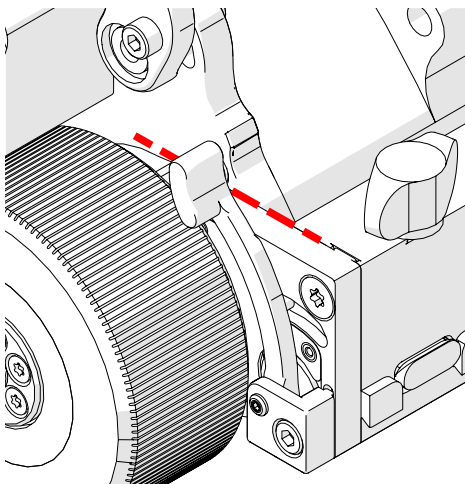

Fig. 83 - Swivel mount aligned horizontally

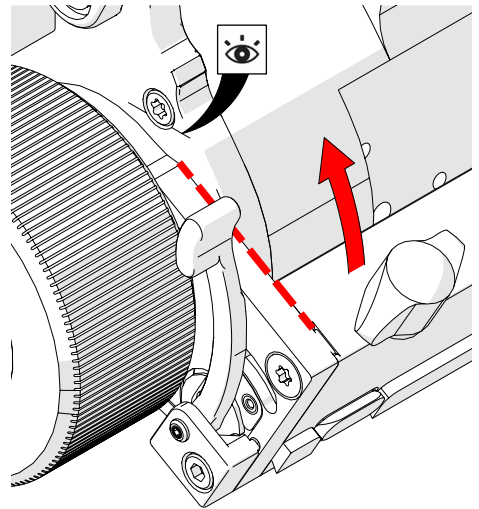

Fig. 82 - Pivot swivel mount

5.3.2. Handle

The handle of the crawler can be moved when required.

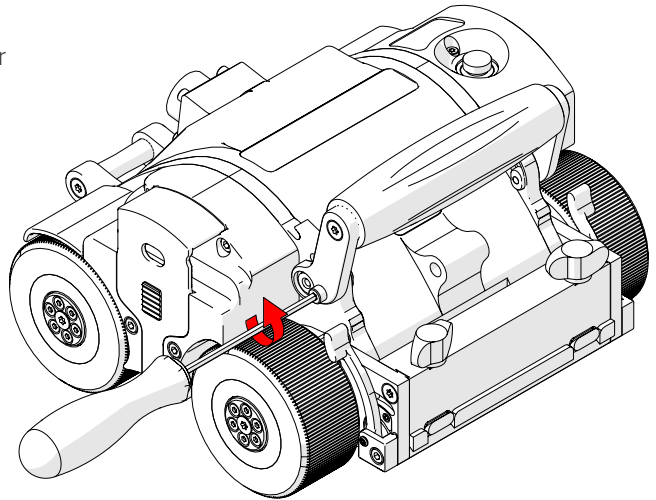

Fig. 84 - Unscrew handle lock screw

1. To lower the handle, use the supplied 3 mm driver to loosen the handle lock screws on either side of the handle (Fig. 84).

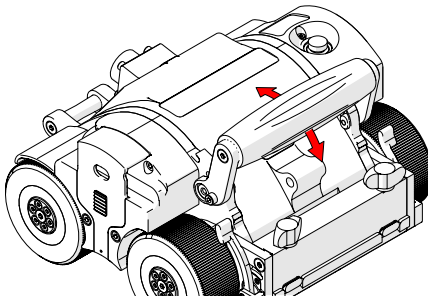

Fig. 85 - Pivot handle as desired

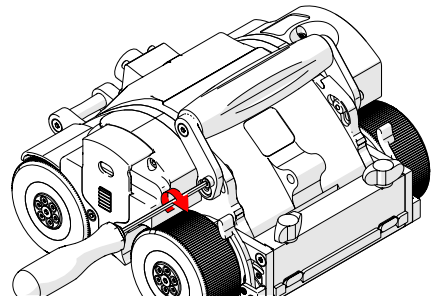

Fig. 86 - Tighten lock screw

2. Pivot the handle as required (Fig. 85).
3. Tighten the handle lock screws when complete (Fig. 86).

5.3.3. Emergency Off Button

The red button on the top left of the crawler provides an emergency off button to the entire system. When pressed, all power to the **MOTIX** system will disengage.

To restore system power, it is necessary to press the power button located on the power controller (see "Power Controller" on page 18).



Fig. 87 - Emergency off

NOTE: Terminating system power may cause the crawler to freewheel around pipe.

5.3.4. Umbilical

To connect the umbilical to the crawler, follow these steps:

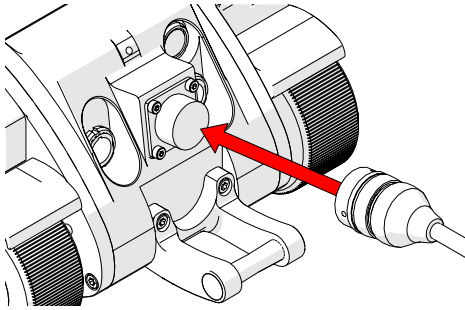

Fig. 88 - Press to umbilical connection

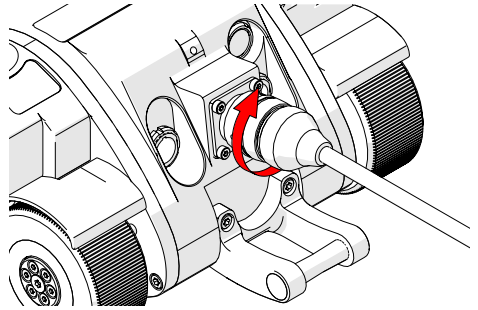

Fig. 89 - Press and rotate to seat pins of umbilical

1. Press the umbilical to the umbilical connection of the crawler (*Fig. 88*).
2. Rotate the umbilical until the umbilical becomes seated in the pins of the umbilical connection (*Fig. 89*).

5.3.5. Cable Retainer

Located on the side of the crawler, the cable retainer offers a means of cable management for cables, hoses and tubes. Gently apply pressure to the grooves of the cable retainer and lift (*Fig. 78*). Route cables, hoses or tubes through the retainer and then press the cable retainer down (*Fig. 88*).

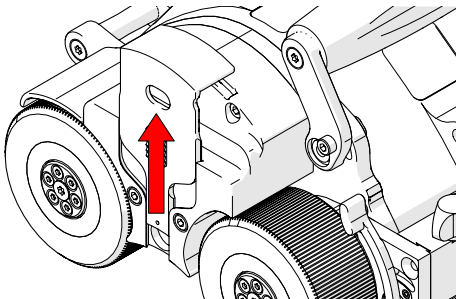

Fig. 90 - Lift retainer by hand

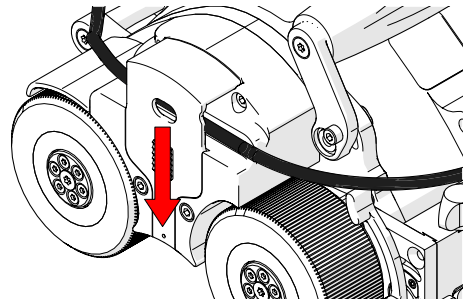

Fig. 91 - Place cables and hoses then close retainer

5.4. Handheld Controller



WARNING! MAGNETIC MATERIAL. The handheld controller produces a strong magnetic field which may cause failure or permanent damage to items such as watches, memory devices, CRT monitors, medical devices or other electronics.



People with pacemakers or ICD's must stay at least 10 cm (4 in) away.



CAUTION! DO NOT DISCONNECT UNDER LOAD. Shut off power before connection or disconnecting. Permanent damage to electronics could occur.



5.4.1. Magnetic Mounts

Magnetic mounts on the rear of the handheld controller assist in preventing the handheld controller from falling.

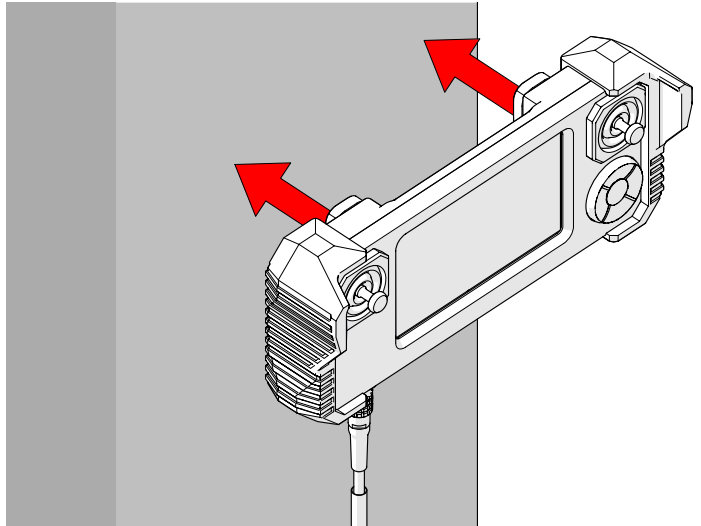

Fig. 92 - Mount to ferrous surfaces

5.5. Chain Connections

5.5.1. Large Overtop Link

The large overtop link (Fig. 16) is designed for use with a motorized raster arm (sold separately) (see "Motorized Raster Arm" user manual) or when using a two probe configuration (see "Two Probe" on page 32).

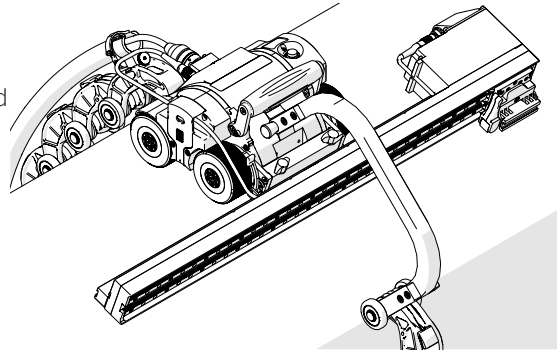

Fig. 93 - Large overtop link

5.5.2. Standard Overtop Link

The standard overtop link is designed for use with cantilever configurations (see "Two or Four Probe Cantilever" on page 30)

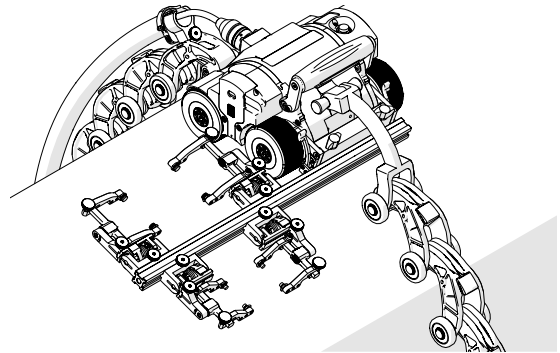

Fig. 94 - Standard overtop link

5.5.3. Connecting Chain Links with Buttons

To connect chain components, see the following steps:

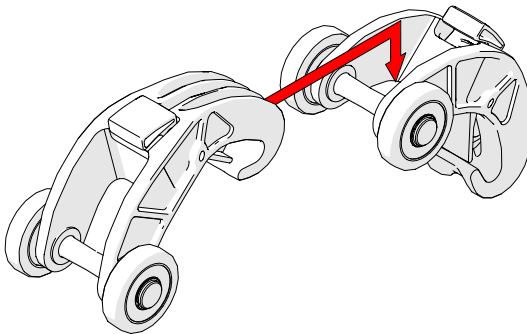

Fig. 95 - Lift the hook over the axle of the link

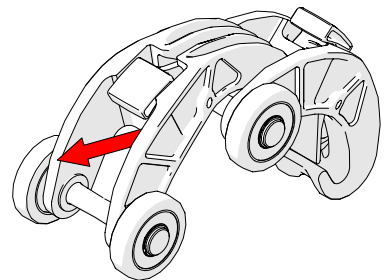

Fig. 96 - Pull the link backwards to secure catch

1. Lift the hook of the short link over the axle of the short link that is to be connected (Fig. 95).

2. Pull the short link until you hear a click that ensures the latch has been set (Fig. 96).

5.5.4. Disconnecting Chain Links with Top Button

To disconnect chain components that have a top button, see the following steps:

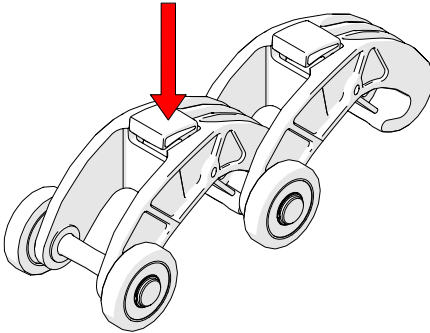

Fig. 97 - Press button

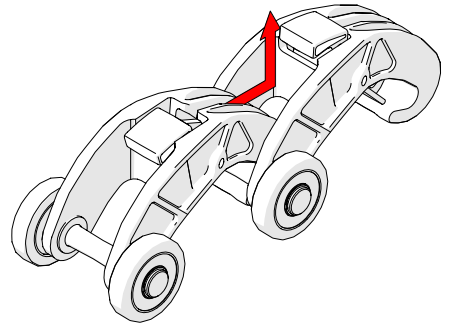

Fig. 98 - Slide link forward and lift

1. Press the button on the top of the short link (Fig. 97).
2. While pressing the button, slide the short link forward and up, clearing the hook of the short link from the 2nd short link's axle (Fig. 98).

5.5.5. Disconnecting Dovetail Link

To disconnect chain components that have a side button, see the following steps:

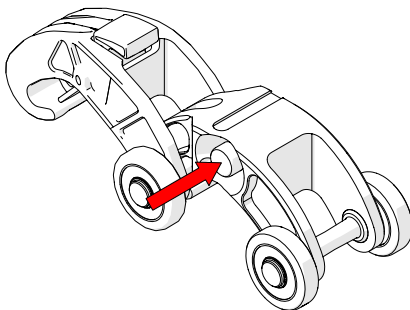

Fig. 99 - Press red button

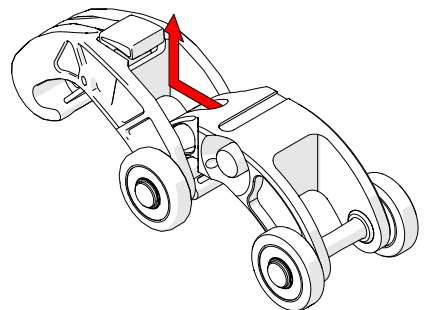

Fig. 100 - Slide link forward and lift

1. Press the button on the side of the dovetail link (Fig. 99).
2. While pressing the red button, slide the dovetail link forward and up, clearing the hook of the dovetail link from the short link's axle (Fig. 100).

5.5.6. Connecting Overtop Links with Pins

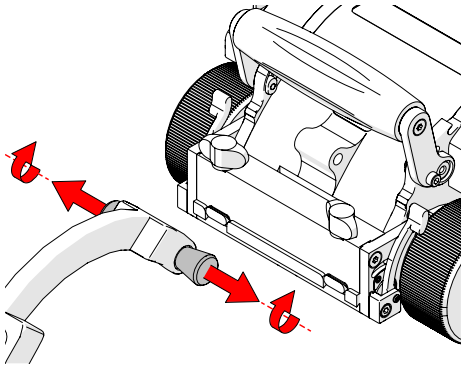

Fig. 101 - Pull pins and twist

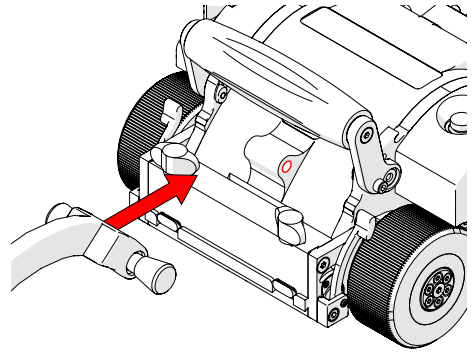

Fig. 102 - Align pins with mounting holes

1. Pull the pins and twist a quarter turn latching the pins in a retracted state (Fig. 101).
2. Align the pins with the mounting holes of the **MOTIX** (Fig. 102).
3. Twist the pins until they unlatch and extend into the connection holes of the **MOTIX** (Fig. 103).

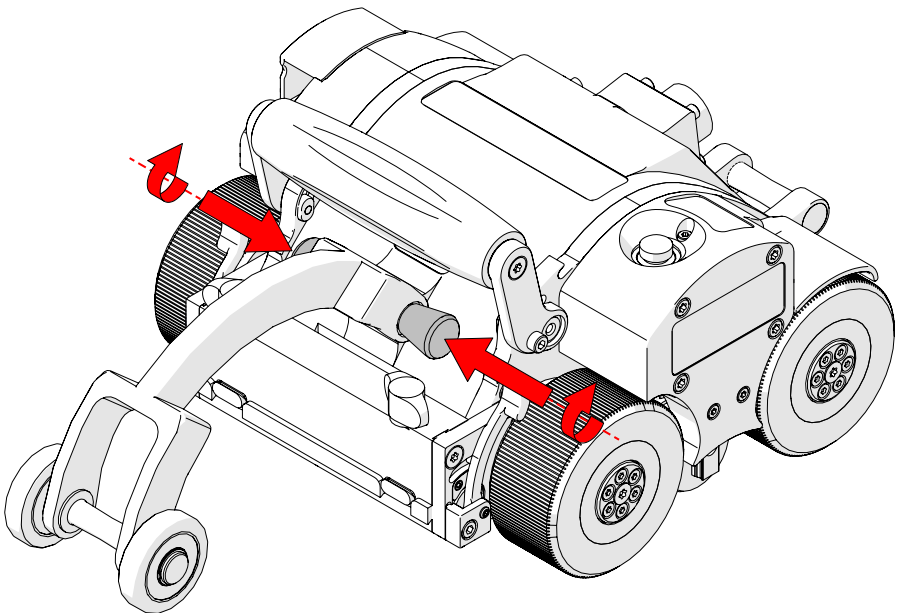

Fig. 103 - Twist pins to unlatch and connect

TIP: Adjustment of the crawler's handle may be required to attach the large overtop link (see "Handle" on page 36).

5.6. Probe Holders

5.6.1. Vertical Probe Holder

- A Latch
- B Probe Holder Adjustment Knob
- C Vertical Adjustment Knob
- D Pivot Buttons
- E Probe Holder Arms
- F Yoke
- G Probe Holder Arm Adjustment Knob
- H Transverse Adjustment Screw
- I Frame Bar

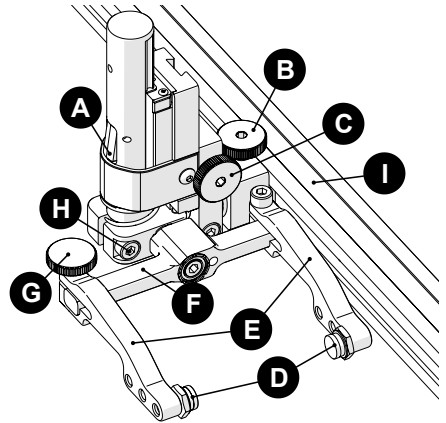

Fig. 104 - Vertical probe holder

5.6.1.1 Probe Holder Setup

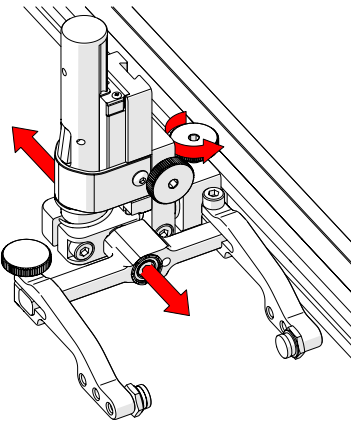

Fig. 105 - Adjust on frame bar

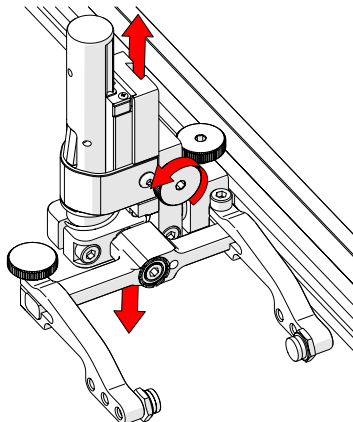

Fig. 106 - Vertical adjustment

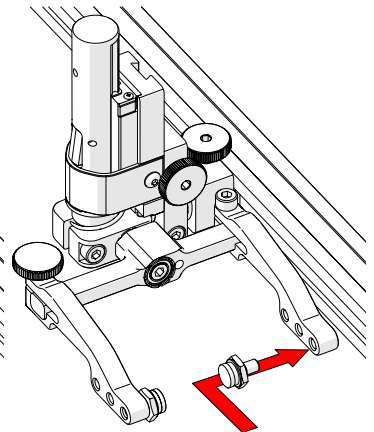

Fig. 107 - Place buttons

1. The probe holder adjustment knob allows the probe holder to be attached to a frame bar, as well as horizontal positioning on a frame bar (Fig. 105).
2. Vertical adjustment knob allows the vertical probe holder height adjustment (Fig. 106).
3. Position the pivot buttons where necessary. When a narrow scanning footprint is required, use the pivot button holes closest to the yoke (Fig. 107).

TIP: Probe pivoting may be impeded when closer to the yoke.

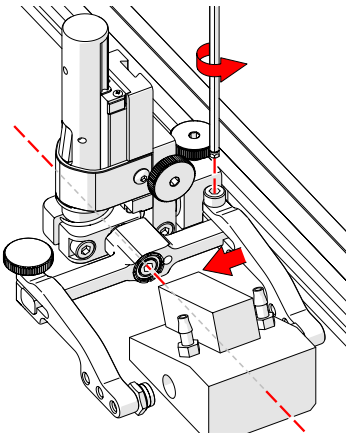

Fig. 108 - Adjust inner arm

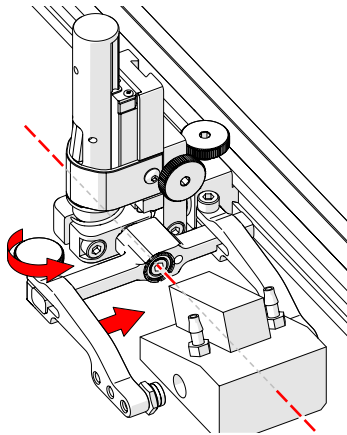

Fig. 109 - Adjust outer arm

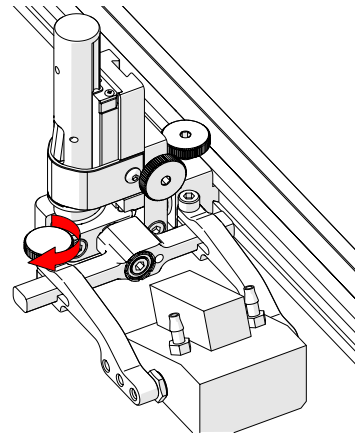

Fig. 110 - Tighten arm knob

4. Position the wedge on the inner probe holder arm (Fig. 108).

TIP: The probe holder yoke can accommodate many different probe and wedge sizes of varying widths. It is best to centre the wedge with the yoke's pivot axis. This can reduce wedge 'rocking' when scanning. Position the inner probe holder arm accordingly (Fig. 108) using the supplied 3 mm hex driver (Fig. 40).

5. Loosen the probe holder arm adjustment knob (Fig. 109) and slide the probe holder arm along the yoke pinching the wedge in place.
6. Tighten the probe holder arm adjustment knob (Fig. 110).

5.6.1.2 Probe Holder Vertical Adjustment

To adjust the probe holder vertically, follow these steps:

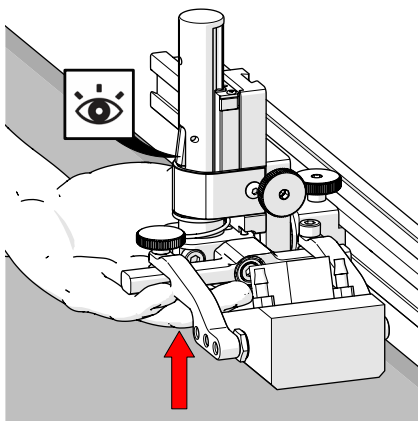

Fig. 111 - Latch probe holder

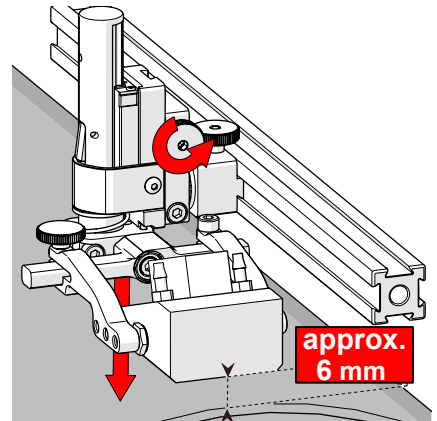

Fig. 112 - Lower toward scan surface

1. Ensure the probe holder is in the latched upper position. Lift the probe holder

until the latch is fully exposed and snaps out to lock (Fig. 111).

2. Loosen the vertical adjustment knob and slide the probe holder down until the wedge is approximately 6 mm ($\frac{1}{4}$ in) above inspection surface.
3. Tighten the vertical adjustment knob (Fig. 112).

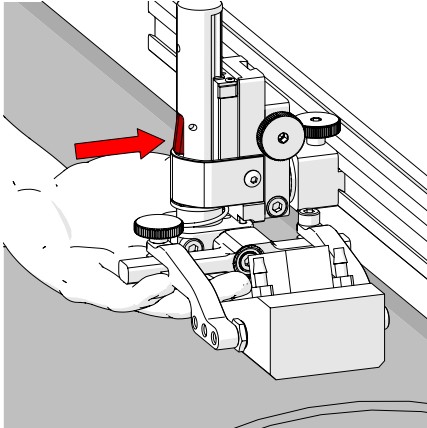

Fig. 113 - Press latch button

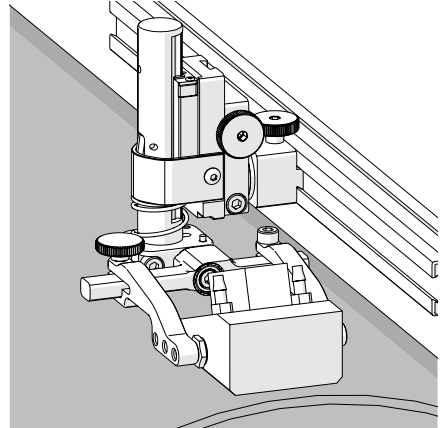

Fig. 114 - Lower toward scan surface

4. Lift the yoke slightly and press the latch button (Fig. 113), then slowly lower towards scanning surface to apply spring pressure to the wedge (Fig. 114).

TIP: If less spring force is desired, refer to step 2 and place the wedge approximately 20 mm ($\frac{3}{4}$ in) above inspection surface.

5.6.1.3 Probe Holder Transverse Adjustment

To adjust the probe holder's transverse angle, follow these steps:

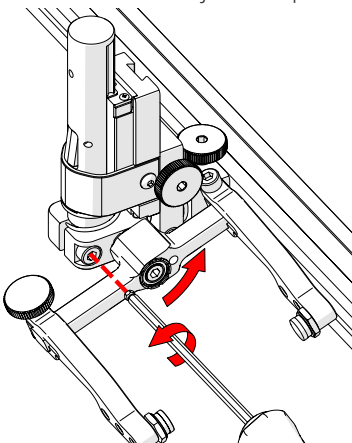

Fig. 115 - Loosen 3 mm screw

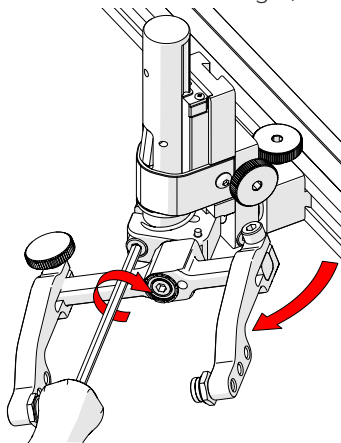

Fig. 116 - Rotate and tighten

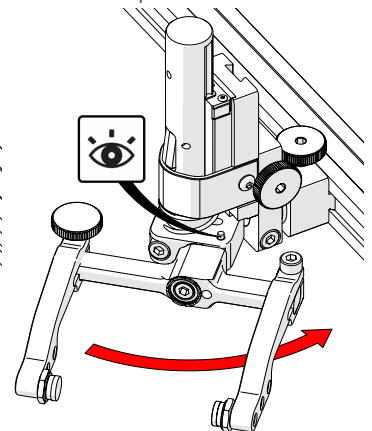

Fig. 117 - Stop post locates 90°

1. Ensure the probe holder is in the latched upper position (Fig. 111).

- Using the supplied 3 mm hex driver loosen the transverse adjustment screw (Fig. 115) and rotate the yoke about the vertical shaft achieving the desired angle.
- Tighten the transverse adjustment screw (Fig. 116).

To return the transverse adjustment to neutral (90°). The probe holder must be in the latched, upper position (Fig. 111). Rotate the yoke until the stop post contacts the base of the probe holder (Fig. 117). Then tighten the transverse adjustment screw.

5.6.1.4 Probe Holder Longitudinal Adjustment

To adjust the probe holder's vertical angle for longitudinal scanning, follow these steps:

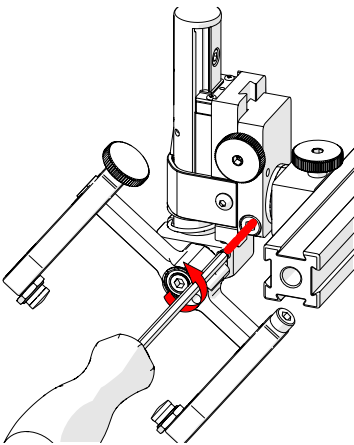

Fig. 118 - Loosen 3 mm screw

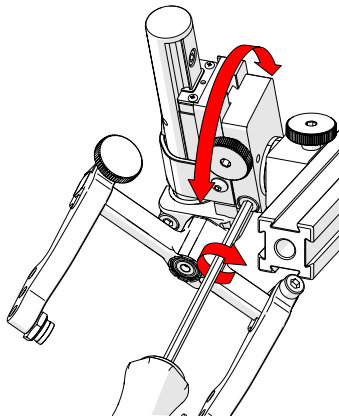

Fig. 119 - Rotate to position

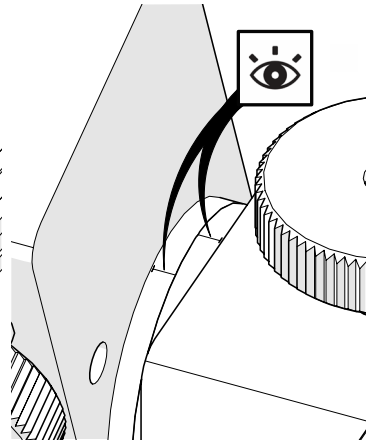

Fig. 120 - Line up markers

- Ensure the probe holder is in the latched upper position (Fig. 111).
- Using the supplied 3 mm hex driver (Fig. 40), loosen the longitudinal adjustment screw (Fig. 118).
- Rotate the main body of the probe holder until it is at the desired angle (Fig. 119).
- Tighten the longitudinal adjustment screw (Fig. 119).

To return the longitudinal adjustment to neutral (90°). Line up the longitudinal adjustment indicator markers (Fig. 120).

5.6.1.5 Probe Holder Left/Right Conversion

To reverse the probe holder, follow these steps:

NOTE: To perform this operation the 1.5 mm hex wrench (Fig. 42) is required.

1. Ensure the probe holder is in the latched upper position (Fig. 111).

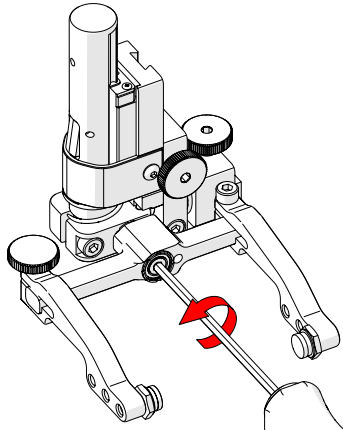

Fig. 121 - Unscrew yoke pivot screw

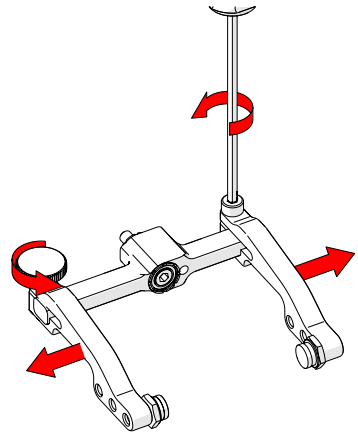

Fig. 122 - Remove probe holder arms

2. Using the supplied 3 mm hex driver (Fig. 40), unscrew the yoke pivot screw and remove the yoke (Fig. 121).
3. Loosen the probe holder arm adjustment knob and the arm clamp screw. Slide the probe holder arms off the yoke (Fig. 122).

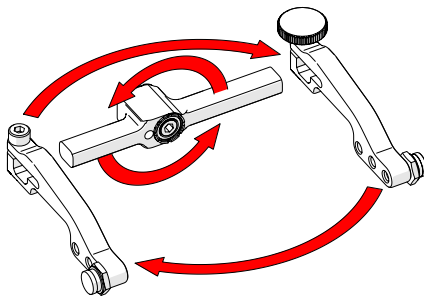

Fig. 123 - Flip yoke and reverse arms

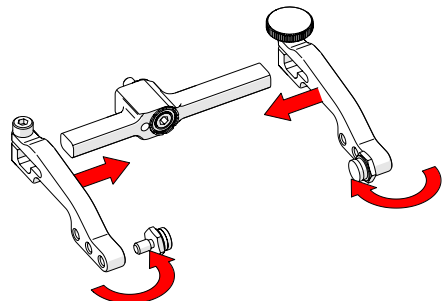

Fig. 124 - Attach arms & move buttons

4. Flip the yoke 180° and reverse the probe holder arms (Fig. 123).
5. Place the pivot buttons on the inside of the probe holder arms (Fig. 124) using a 3/8 in wrench (Fig. 41).

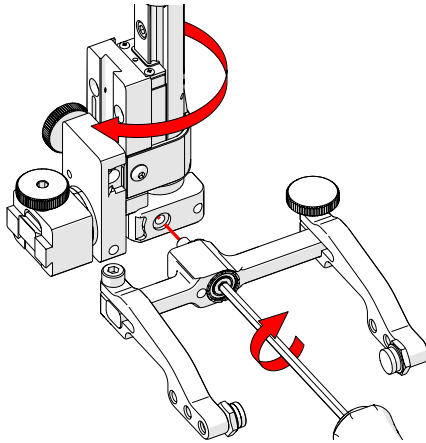

Fig. 125 - Screw yoke to opposite side

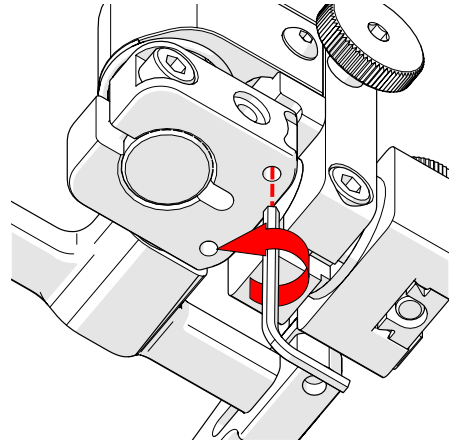

Fig. 126 - Lower 90° stop post

6. Mount the yoke to the opposite side of the base using the supplied 3 mm hex driver (Fig. 125).

TIP: Keep the yoke level with the base to ensure no conflicts with the plunger/set screw attached to the yoke.

7. Locate the recessed M3 screw (stop post) on the bottom of the probe holder. Unscrew the stop post using a 1.5 mm hex wrench until it has cleared all obstructions. Do not remove stop post (Fig. 126).

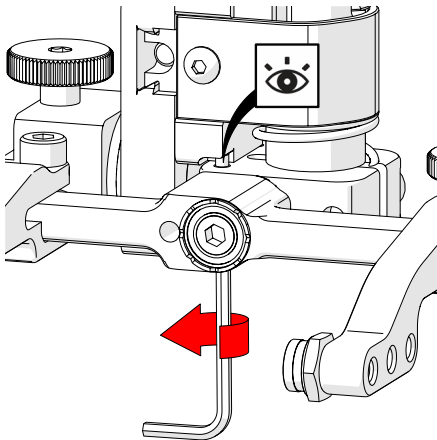

Fig. 127 - Raise opposite 90° stop post

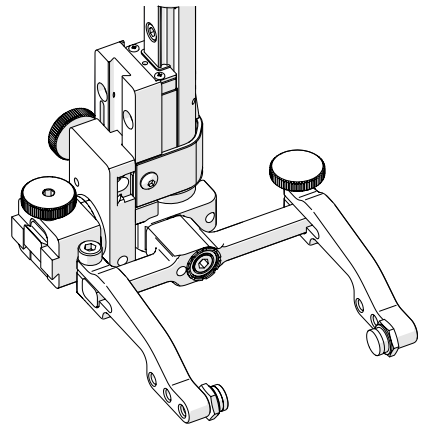
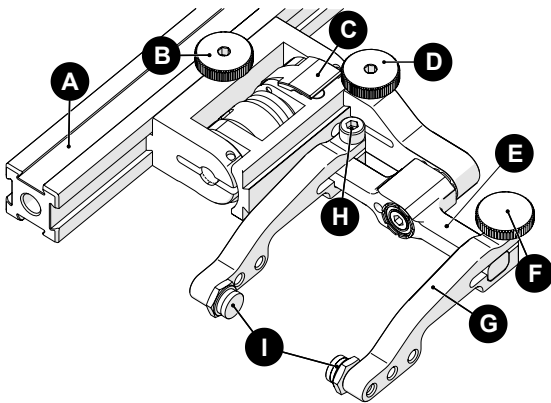

Fig. 128 - Reversed probe holder

8. Raise the stop post on the opposite side until the side of the post clearly contacts the 90° stop point on the probe holder's base (Fig. 127).

5.6.2. Slip Joint Probe Holder



A	Frame Bar
B	Probe Holder Adjustment Knob
C	Latch
D	Swing Arm Knob
E	Yoke
F	Probe Holder Arm Adjustment Knob
G	Probe Holder Arm
H	Arm Clamp Screw
I	Pivot Buttons

Fig. 129 - Slip Joint Probe Holder

5.6.2.1 Probe Holder Setup

To mount a UT wedge in the probe holder, follow these steps:

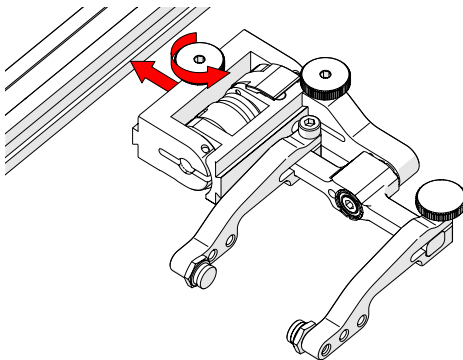

Fig. 130 - Attach to frame bar

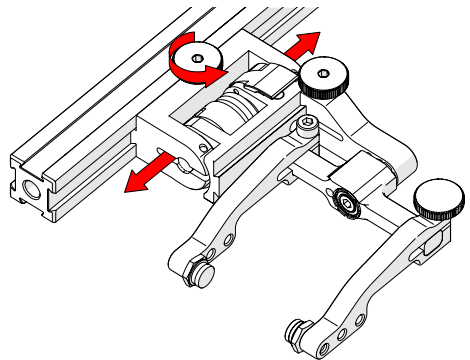

Fig. 131 - Adjust on frame bar

1. Rotate the probe holder adjustment knob and attach the probe holder to a frame bar (Fig. 130).
2. Use the probe holder adjustment knob to position the probe holder along the frame bar (Fig. 131).

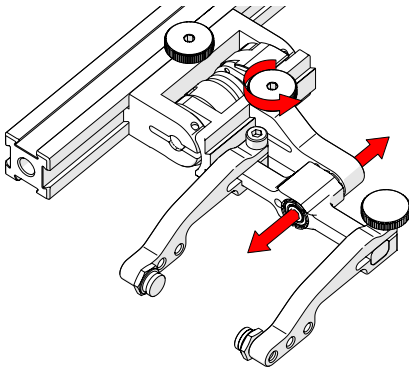

Fig. 132 - Adjust swing arm

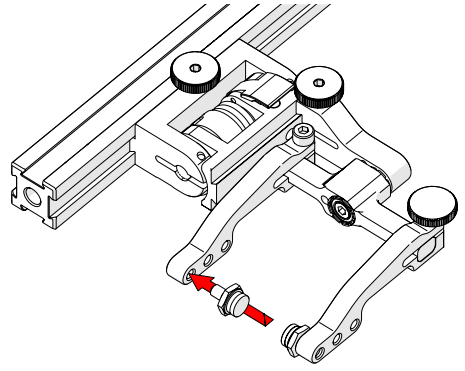

Fig. 133 - Place pivot buttons

3. Use swing arm knob to position the swing arm (Fig. 132).

TIP: The swing arm is typically used to adjust TOFD center to center distance relative to the phased array probes on a four probe configuration.

4. Using the supplied 3/8 in wrench (Fig. 41), place the pivot buttons (Fig. 133) farthest from the yoke for maximum wedge clearance.

TIP: If narrow scanning footprint is required, use pivot button holes closest to the yoke. Wedge pivoting may be impeded when closer to the yoke.

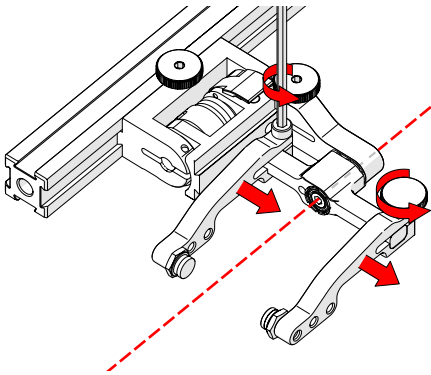

Fig. 134 - Adjust probe holder arms

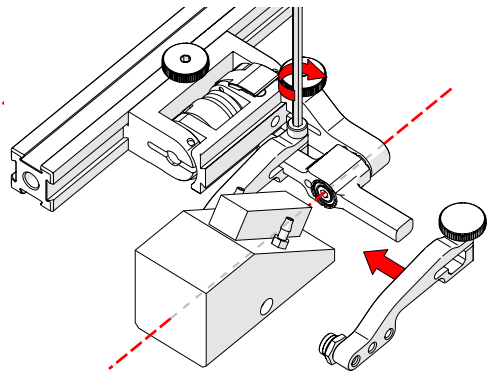

Fig. 135 - Place wedge

5. Loosen the probe holder arm adjustment knob (Fig. 134) and remove outer probe holder arm from yoke.
6. Adjust the inner probe holder arm as required to best centre the probe on the yoke's pivot axis (Fig. 134).

TIP: The probe holder yoke can accommodate many different probe and wedge sizes of varying widths. It is best to centre the wedge with the yoke's pivot axis to reduce wedge tipping when scanning. Position the inner probe holder arm accordingly with the centre of the yoke (Fig. 134).

7. Position the wedge on the inner probe holder arm (Fig. 135).
8. Slide outer probe holder arm along the yoke pinching the wedge in place.
9. Tighten probe holder arm adjustment knob (Fig. 136).

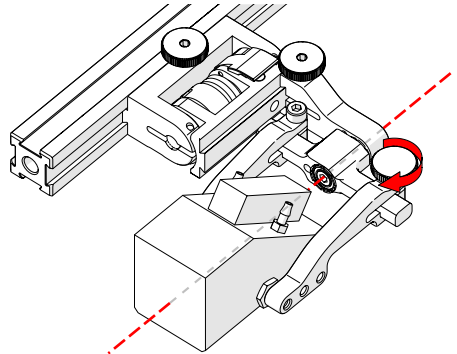

Fig. 136 - Pinch wedge with arm

5.6.2.2 Probe Holder Adjustment

To adjust the probe holder, follow these steps:

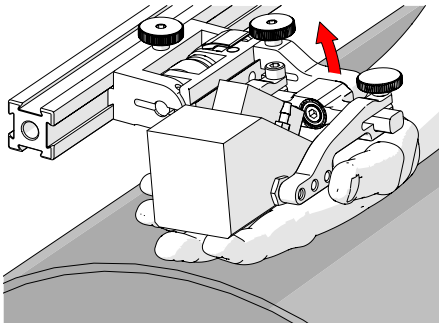

Fig. 137 - Lift to latched position

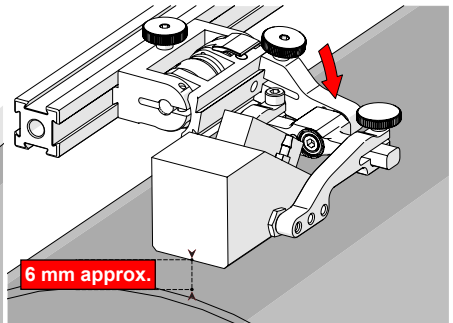

Fig. 138 - Lower to scanning surface

1. Ensure probe holder is in latched, upper position (Fig. 137). If the probe holder is already latched, it will only move within the slip joint adjustment range and have no spring tension.
2. Push the probe holder yoke down toward the inspection surface until the wedge is approximately 6 mm ($\frac{1}{4}$ in) from the inspection surface (Fig. 138).

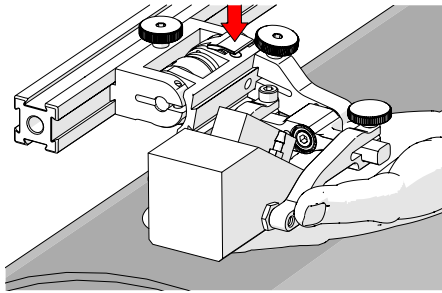

Fig. 139 - Lift and press latch button

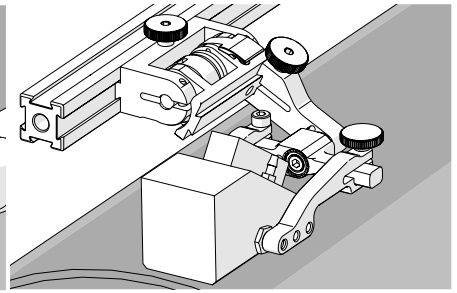

Fig. 140 - Spring loaded scan position

3. Lift probe slightly and press latch button (Fig. 139) to apply spring pressure to the wedge.
4. Gently lower probe holder and wedge to the scanning surface (Fig. 140).

5.6.2.3 Probe Holder Force Adjustment

It is possible to adjust the tension of the probe holder spring.

NOTE: The 2 mm hex wrench (Fig. 43) and 3 mm hex wrench (Fig. 44) are required to perform this operation.

Light	1 kg	2 lb
Medium	2 kg	4 lb
Heavy	3 kg	6 lb

When configured correctly, these settings exert the indicated spring force on the Probe.

To adjust the probe holder's force, follow these steps:

NOTE: Do not perform this operation on scanning surface.

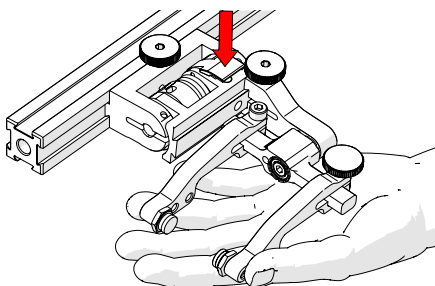

Fig. 141 - Lift slightly and press latch

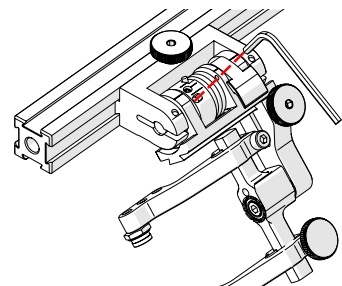

Fig. 142 - Unlatched position

1. Ensure the probe holder is in the upright latched position (Fig. 137).
2. Lift probe holder slightly and press the latch button (Fig. 141) to release the probe holder the full 45° degrees.
3. Insert the short arm of a 3 mm hex wrench into the 3 mm slot (Fig. 142).

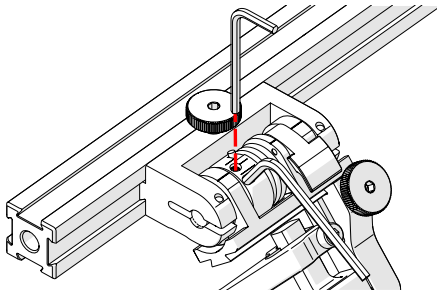

Fig. 143 - Insert hex tools

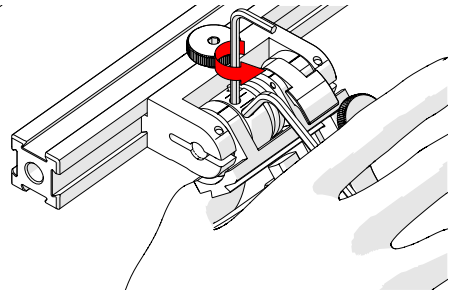

Fig. 144 - Press 3 mm hex wrench down

4. Place the 2 mm hex wrench into the force adjustment screw (*Fig. 143*).
5. Lightly press the long arm of the 3 mm hex wrench down. Using the 2 mm hex wrench, loosen the force adjustment screw but do not remove it (*Fig. 144*).
6. Gently apply pressure on the long leg of the 3 mm hex wrench until the force adjustment marker lines up with the desired spring tension. While keeping the markers in line, tighten the force adjustment screw (*Fig. 145*).

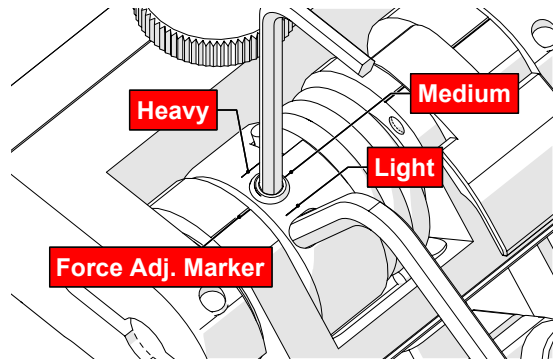

Fig. 145 - Choose desired tension

5.6.2.4 Slip Joint Probe Holder Left/Right Conversion

To reverse the probe holder, follow these steps:

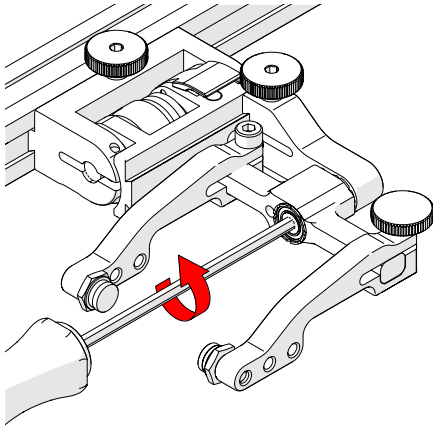

Fig. 146 - Unscrew yoke pivot screw

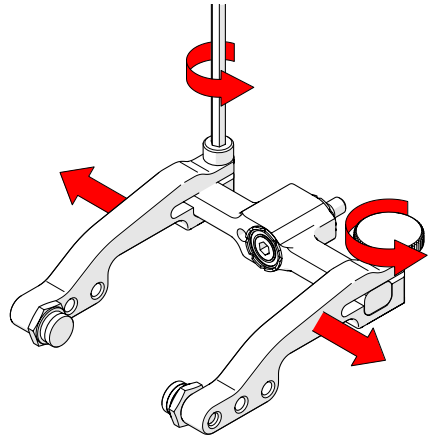

Fig. 147 - Remove arms

1. Unscrew the yoke from the swing arm (Fig. 146).
2. Loosen the probe holder arm adjustment knob and arm clamp screw. Slide the arms from the yoke (Fig. 147).

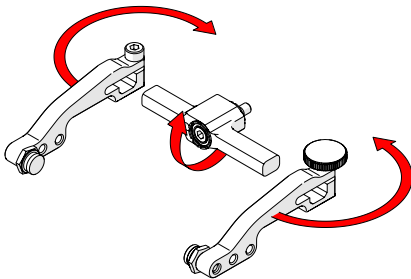

Fig. 148 - Flip yoke and reverse arms

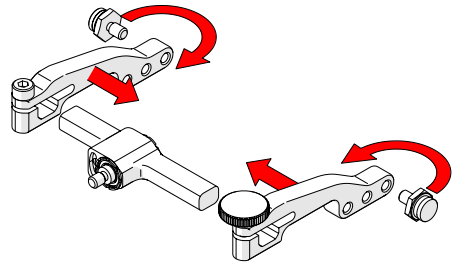

Fig. 149 - Attach arms and move buttons

3. Flip the yoke 180° and reverse the probe holder arms (Fig. 148).
4. Place the pivot buttons on the inside of the probe holder arms (Fig. 149) using a 3/8 in wrench (Fig. 2). Slide the arms onto the yoke and tighten the probe holder arm adjustment knob and the arm clamp screw.

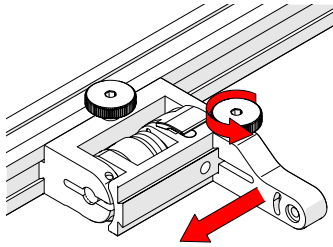

Fig. 150 - Position swing arm

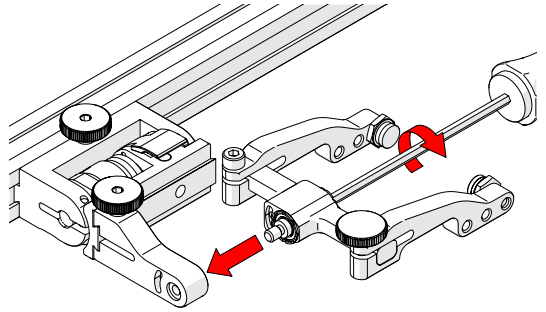

Fig. 151 - Install yoke to swing arm

5. Loosen the swing arm knob and slide the swing arm to the opposite end of the probe holder bracket (*Fig. 150*) or preferred position. Tighten swing arm knob.
6. Using the 3 mm hex driver, screw the yoke pivot screw into the opposite side of the probe holder swing arm (*Fig. 151*). Ensure the yoke is level to avoid issues with the plunger/set screw.

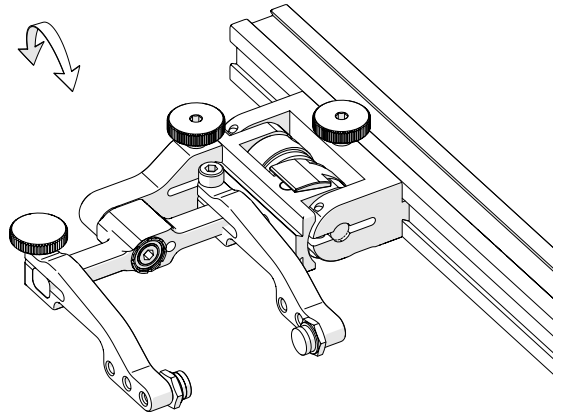

Fig. 152 - Reversed probe holder

5.6.3. Heavy Duty Vertical Probe Holder

- A Latch
- B Probe Holder Arm Adjustment Knob
- C Yoke
- D Probe Holder Arms
- E Pivot Buttons
- F Arm Clamp Screw
- G Probe Holder Adjustment Knob
- H Vertical Adjustment Knob

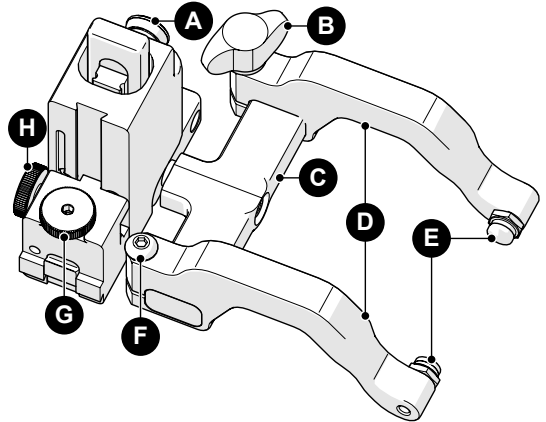

Fig. 153 - Heavy duty vertical probe holder

5.6.3.1 Probe Holder Setup

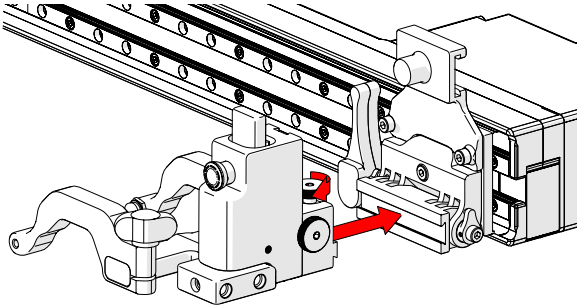

Fig. 154 - Mount probe holder to carrier

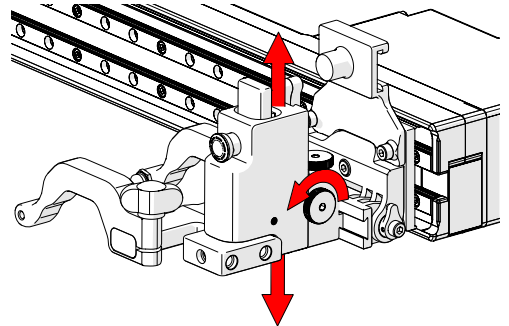

Fig. 155 - Vertical adjustment

1. Loosen the probe holder adjustment knob (*Fig. 154*) and mount the heavy duty vertical probe holder's dovetail jaw to the carrier.
2. The vertical adjustment knob (*Fig. 155*) allows the heavy duty vertical probe holder's height adjustment. This adjustment also controls the probe holder's spring tension.

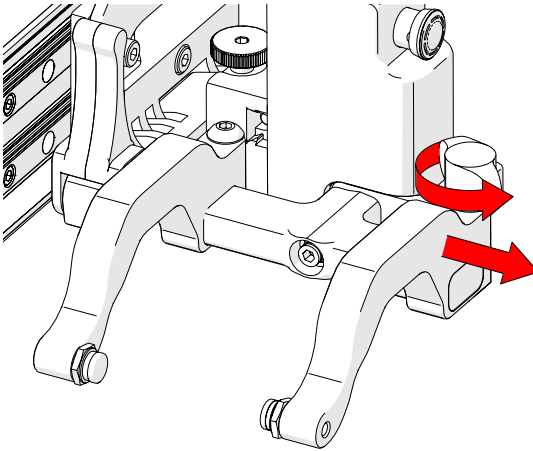

Fig. 156 - Remove outer arm

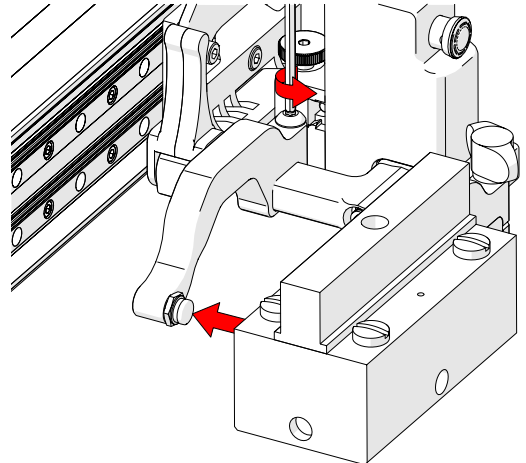

Fig. 157 - Adjust inner arm

3. Loosen the probe holder arm adjustment knob and remove the outer probe holder arm (Fig. 156).
4. Loosen the arm clamp screw (Fig. 157).
5. Place the wedge on the pivot button of the inner probe holder arm (Fig. 157).

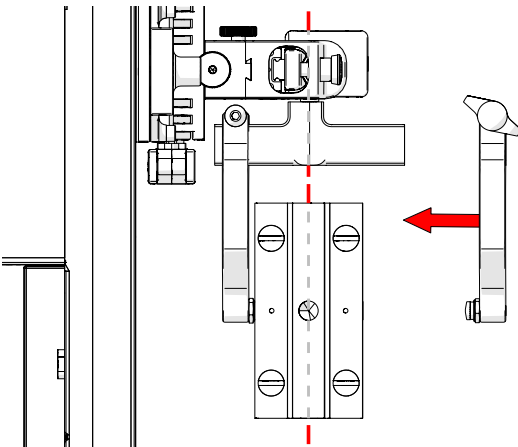

Fig. 158 - Align probe with yoke

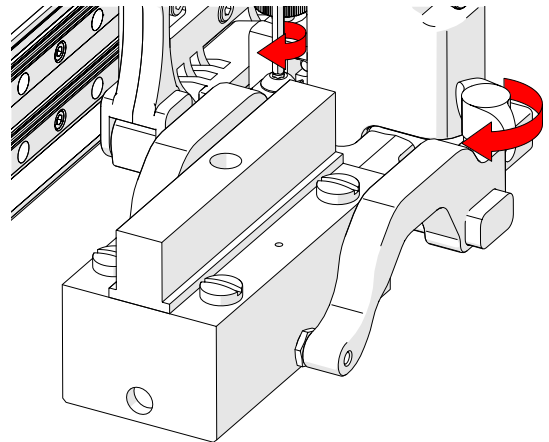

Fig. 159 - Tighten knob and screw

6. Align the middle of the wedge with the centre of the yoke (Fig. 158).
7. Tighten both the probe holder arm adjustment knob and the arm clamp screw (Fig. 158) while ensuring the wedge remains centred with the yoke.

5.6.3.2 Probe Holder Vertical Adjustment

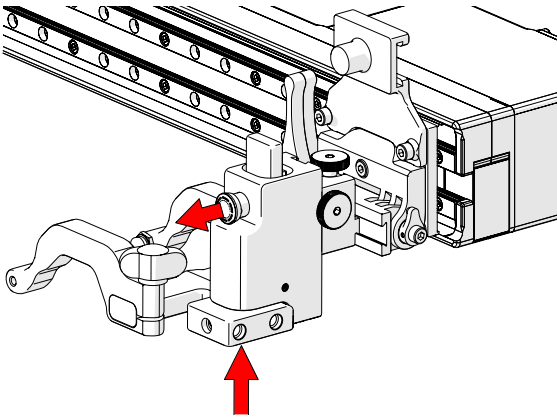

Fig. 160 - Press up and pull latch

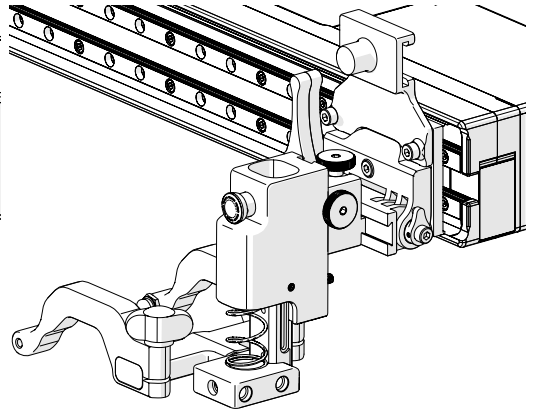

Fig. 161 - Lowered toward scan surface

1. Gently lift the heavy duty vertical probe holder and simultaneously pull the latch (Fig. 160). This action will unlock the probe holder. Slowly lower the probe holder towards the scan surface (Fig. 161).

5.6.3.3 Probe Holder Left/Right Conversion

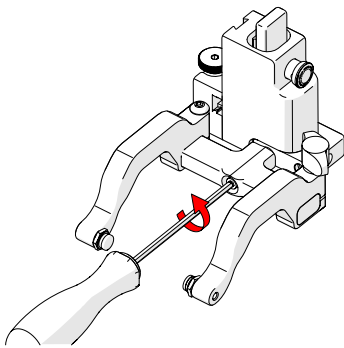

Fig. 162 - Remove yoke

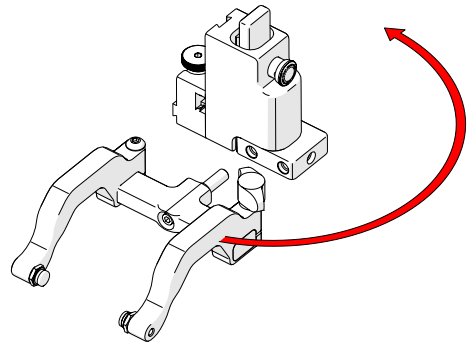

Fig. 163 - Orient to opposite side

1. Using the supplied 3 mm driver, unscrew the yoke (Fig. 162).
2. Position the yoke and arms to the opposite side of the probe holder (Fig. 163).

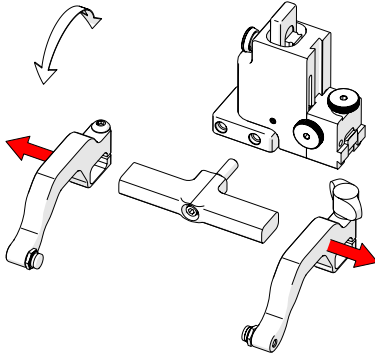

Fig. 164 - Remove probe holder arms

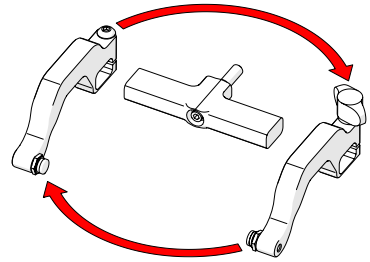

Fig. 165 - Reverse position around yoke

3. Loosen the arm clamp screw and probe holder arm adjustment knob allowing removal of the probe holder arms (Fig. 164).
4. Position removed arms to opposite sides of the yoke (Fig. 165).

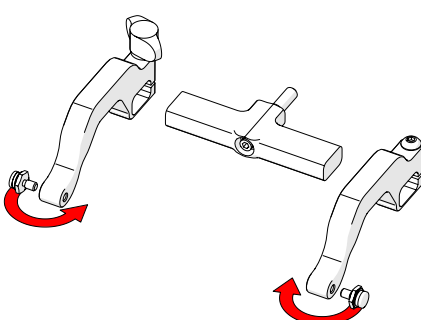

Fig. 166 - Position pivot buttons

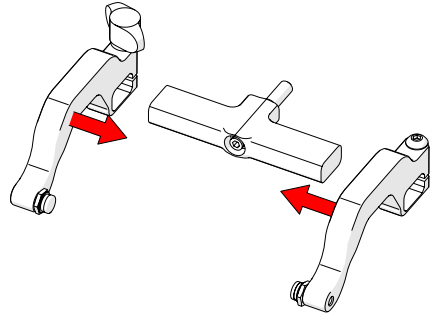

Fig. 167 - Place arms back onto yoke

5. Position the pivot buttons to the inside of the probe holder arms (Fig. 166).
6. Place the probe holder arms on the yoke and tighten the arm clamp screw and probe holder adjustment knob (Fig. 167).
7. Screw the yoke to the probe holder (Fig. 168).

TIP: When using a standard yoke length, position the yoke in the threaded hole closest to the frame bar. When using a wide yoke length, position the yoke in the threaded hole furthest from the frame bar.

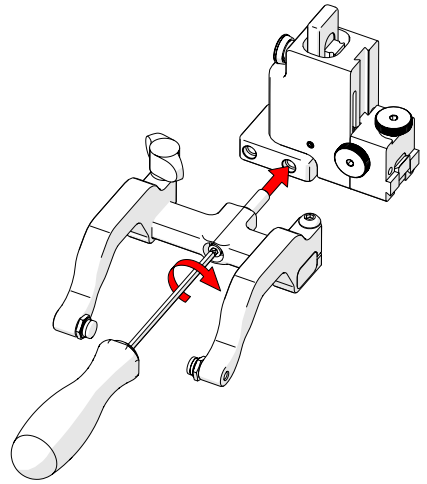

Fig. 168 - Screw into threaded hole

5.6.4. Cable Clips

Cable clips have been provided to assist with cable management. Simply pinch the clip and press it into the dovetail groove of the frame bar or the probe holder.

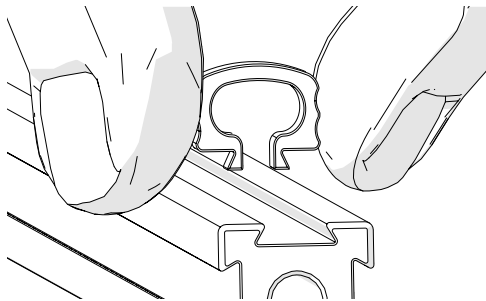

Fig. 169 - Pinch clip

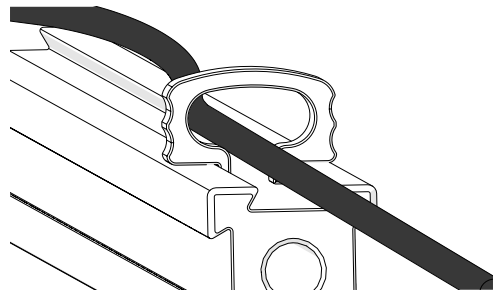

Fig. 170 - Cable clip

5.7. Battery Powered Optical Guide



WARNING! LASER RADIATION. The battery powered optical guide contains a Class 1M laser. Do not view directly with optical instruments.

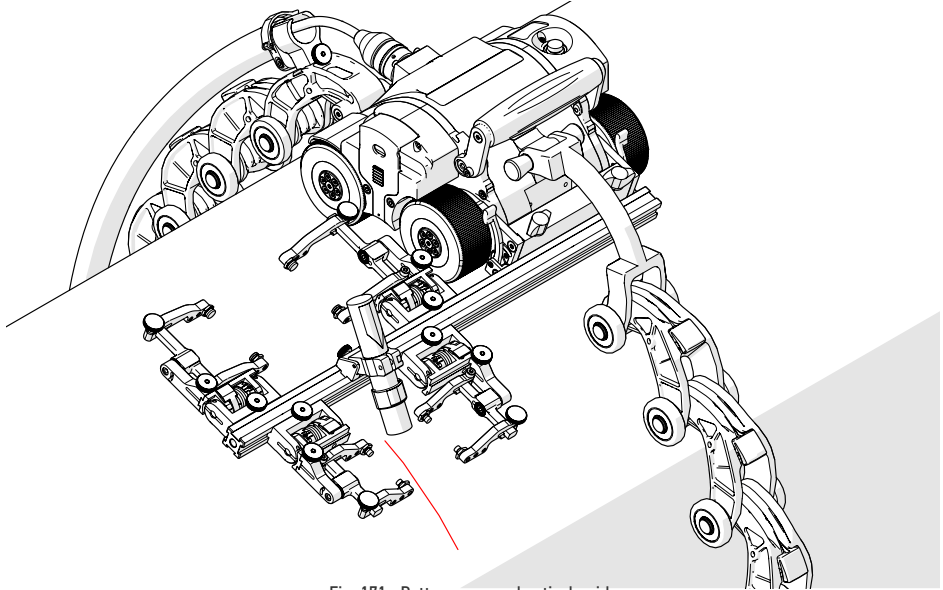

Fig. 171 - Battery powered optical guide

The battery powered optical guide provides a reference point to align the **MOTIX** to a given path (*i.e. a weld*).

1. Loosen the battery powered optical guide knob (*Fig. 172*) and mount the optical guide to the frame bar.
2. Tighten the optical guide knob.
3. Adjust the optical guide's friction pivot to direct the laser beam as required (*Fig. 173*).
4. Loosen the optical guide knob to adjust the side-to-side position as required. Retighten the optical guide knob.

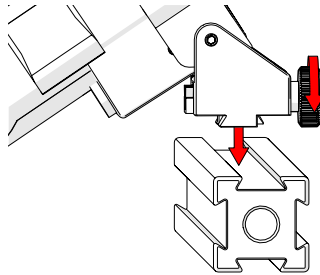

Fig. 172 - Mount on frame bar

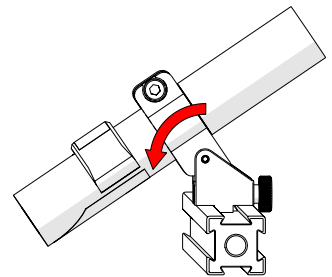

Fig. 173 - Aim guide

5. The included perpendicular mount allows for alternate mounting positions when required.

NOTE: *The battery powered optical guide requires 1 AA battery for operation.*

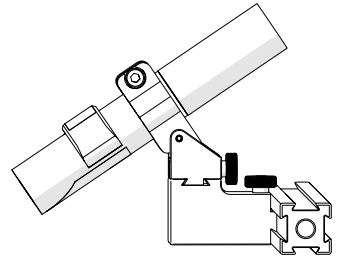

Fig. 174 - Perpendicular mount

5.8. Cable Management

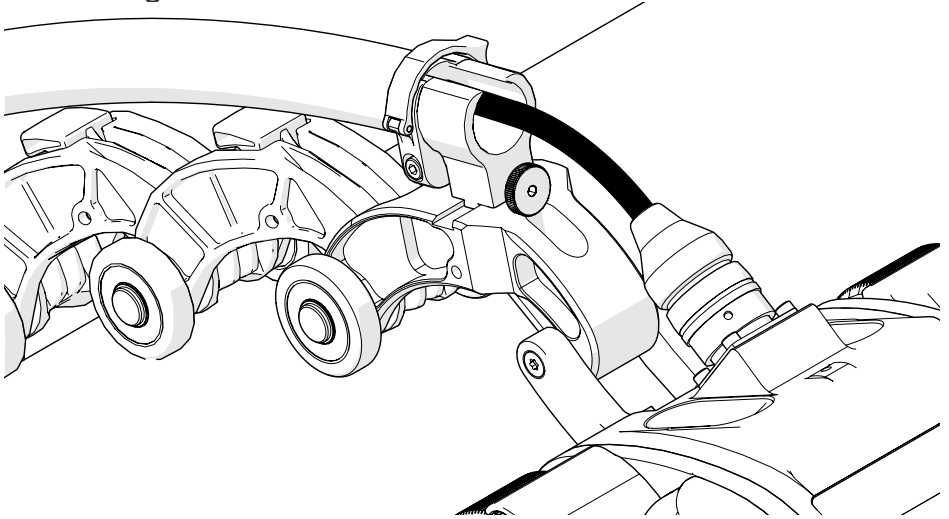

Fig. 175 - Cable management

5.8.1. Cable Management Dovetail Mount

To attach the cable management, follow these steps:

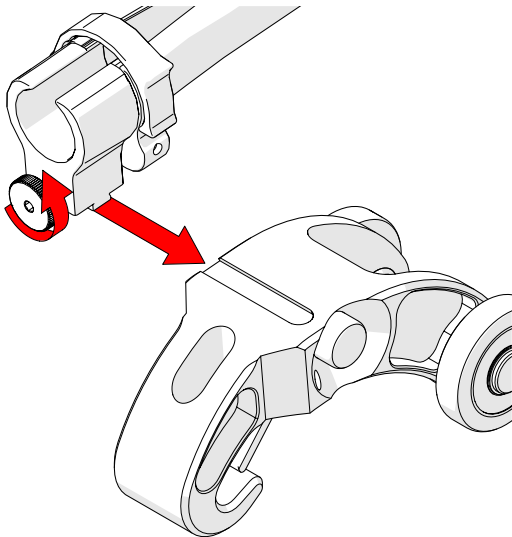

Fig. 176 - Loosen and slide on

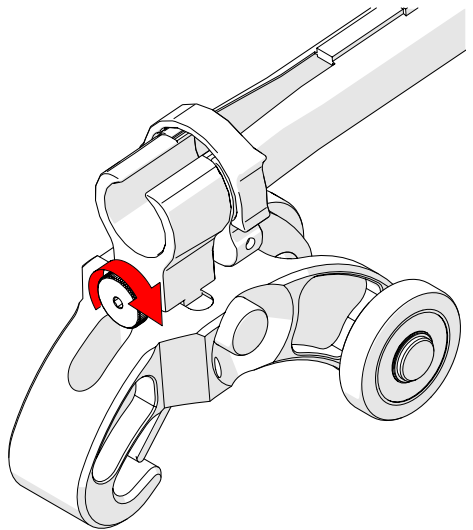

Fig. 177 - Tighten knob

1. Loosen the knob on the cable management dovetail mount. Slide the mount onto the dovetail link (Fig. 176).
2. Once centred on the dovetail link, tighten the cable management's dovetail mount knob (Fig. 177).

5.8.2. Cable Management Setup

The cable management is available in a variety of lengths and provides a means of bundling and protecting cables and hoses that run to the scanner.

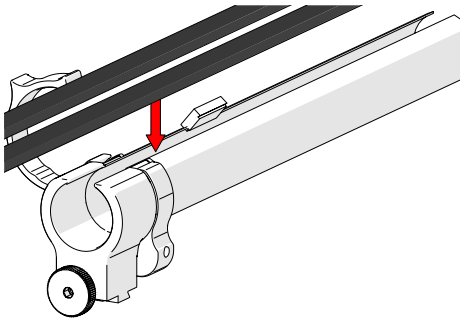

Fig. 178 - Insert cables and hoses

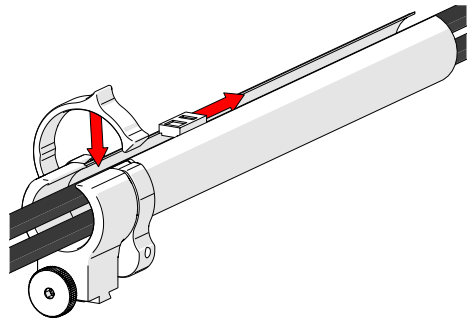

Fig. 179 - Zip up to close

1. Open the cable management. Begin at the tube's dovetail mount and place the cabling in the tube (*Fig. 178*).
2. Follow the cable placement zipping the tube closed (*Fig. 179*).

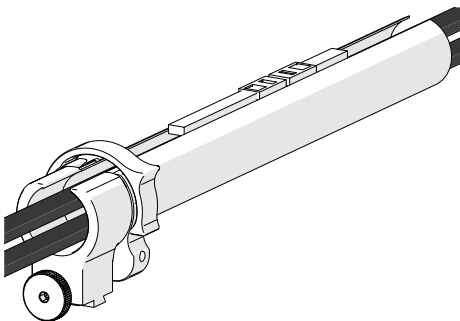

Fig. 180 - Zip opposite end

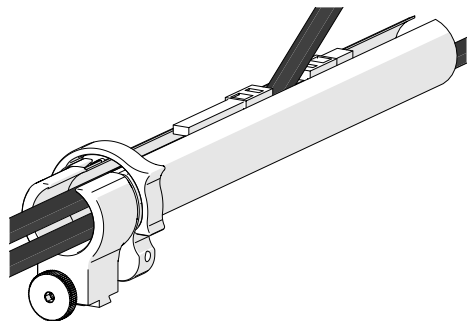

Fig. 181 - Flexibility

3. Once the cable is placed the entire length of tube, bring the zipper from the tubes opposite end, meeting at any point in the middle (*Fig. 180*).
4. When necessary, the two zippers may be opened to allow any cables to exit the tube anywhere between the ends (*Fig. 181*).

5.8.3. Clamp Setup

If the tube becomes disconnected from the cable management dovetail mount, follow these instructions to re-attach the tube and dovetail mount.

1. Loosen the clamp screw using the supplied 3 mm hex driver.
2. Slide the clamp around the tube first and then slide the tube around the outside of the cable management dovetail mount (Fig. 182). Align the zipper opening and the cable management dovetail mount opening.
3. Slide the clamp over the tube and cable management dovetail mount pinching the tube in between (Fig. 183).
4. Tighten the clamp screw (Fig. 184).

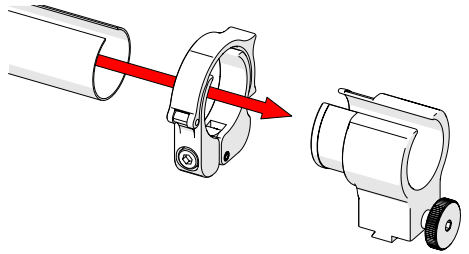

Fig. 182 - Slide tube around mount

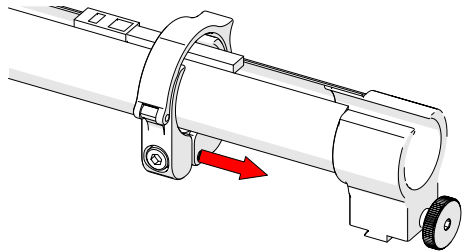

Fig. 183 - Slide clamp onto mount

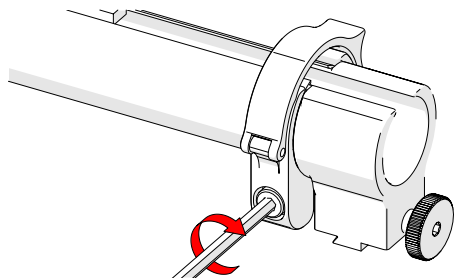

Fig. 184 - Tighten clamp screw

5.9. Preamp Bracket

Compatible with most standard preamps, use screws or the optional velcro straps to attach a preamp to the preamp bracket.

Intended Use

- ▶ The **MOTIX** preamp bracket is intended to mount objects (eg. preamps, splitters, etc) that:
- ▶ have a maximum weight of 1.36 kg (3 lb)
- ▶ are attached to the **MOTIX** with a lanyard or probe cables strong enough to prevent the object from falling
- ▶ have smooth edges so as not to cut bracket's velcro strap

5.9.1. Mounting Preamp Bracket

The preamp bracket mounts to any dovetail groove.

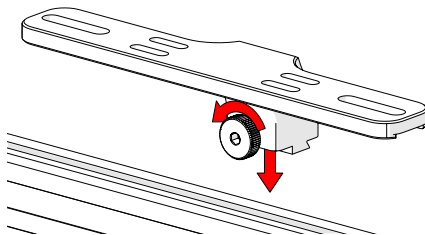

Fig. 185 - Loosen knob and mount to dovetail groove

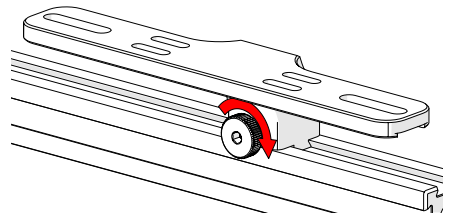

Fig. 186 - Tighten knob

1. Loosen the knob and align with dovetail groove (Fig. 185).
2. Tighten the knob to lock preamp bracket in place (Fig. 186).

5.9.2. Attaching Preamp with Screws

Use the adjustable screw mounting channel on the bottom of the bracket to attach a preamp (screws not included).

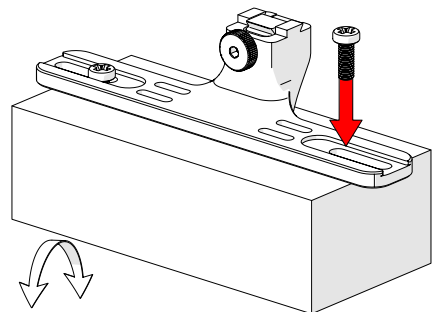

Fig. 187 - Attach preamp with screws

5.9.3. Attaching Preamp with Velcro Straps

To attach the preamp to the bracket using velcro straps, follow these steps:

1. Slide the velcro strap through the bracket's holes (Fig. 188).

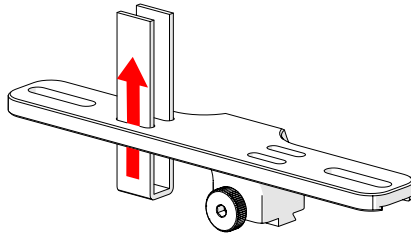

Fig. 188 - Insert velcro straps

2. Centre and place the preamp on the bracket wrapping the velcro around the preamp (Fig. 189).
3. Secure the preamp to the bracket attaching each side of the velcro (Fig. 190).

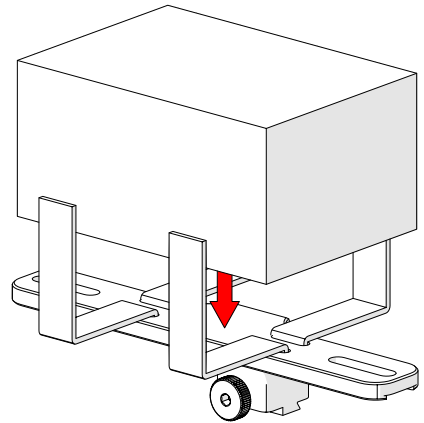

Fig. 189 - Place preamp and wrap velcro

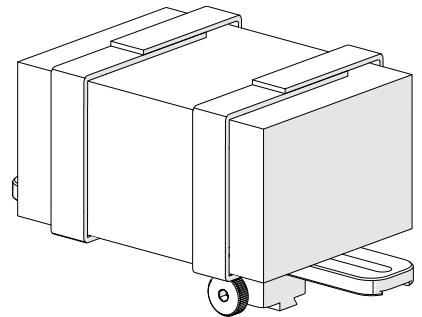

Fig. 190 - Velcro wrapped around preamp

OPERATION

6.1. Setup of MOTIX on a Scanning Surface



CAUTION! Do **NOT** handle crawler using the umbilical cable. Use the provided handle.

1. Assemble the appropriate configuration to the frame bar (see “Configurations” on page 30) and mount to the crawler (Fig. 191).
2. Install the wedge and probes that will be used (see “Slip Joint Probe Holder” on page 25).

TIP: Probes and wedges are not illustrated.

TIP: The following example is a four probe cantilever configuration for a 50.8 cm (20 in) pipe diameter.

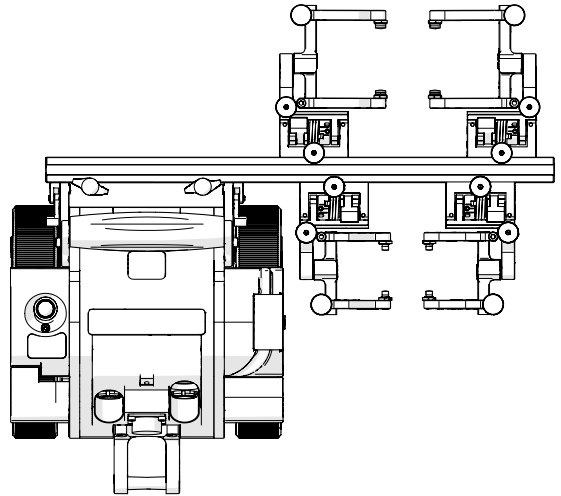

Fig. 191 - Assemble appropriate configuration

3. Determine the diameter of the pipe to be scanned. Included in the **MOTIX** kit and in this manual, is a setup chart which indicates the number of links required based on the diameter of the pipe or tube (Fig. 192).



Fig. 192 - Refer to setup chart

4. On a flat surface, connect the appropriate number of links as indicated on the setup chart (Fig. 193).
(see "Chain Connections" on page 39).
5. Arrange the chain links to place the buckle roughly 180° opposite of the crawler.
6. Connect the umbilical to the crawler (see "Umbilical" on page 37).
7. Connect the cable management to the dovetail link and route the umbilical through the cable management (see "Cable Management" on page 62).
8. Drape the configured assembly around the pipe / tube to be inspected (Fig. 194).

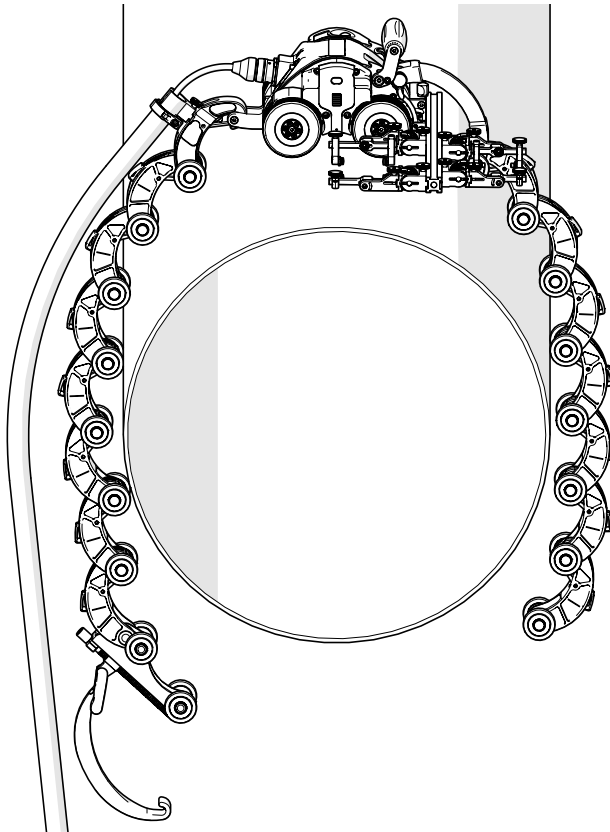

Fig. 194 - Place on pipe / tube

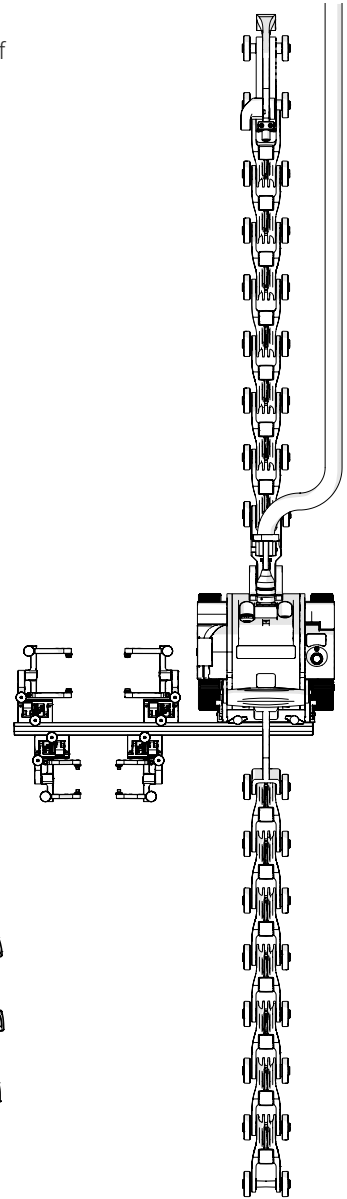

Fig. 193 - Assembled configuration

9. Bring the buckle's arm towards the axle of the opposite chain link. Hook the buckle's arm to the middle axle of the chain link (Fig. 195).

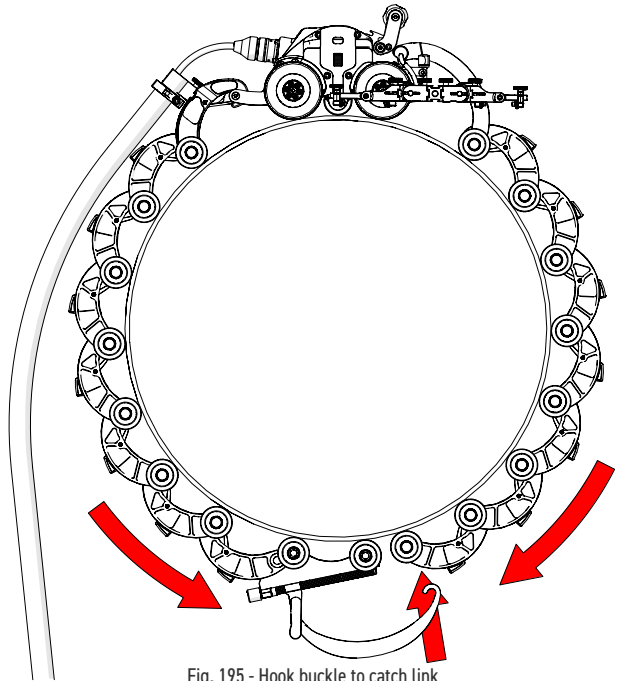

Fig. 195 - Hook buckle to catch link

10. The **1** buckle adjustment knob may have to be loosed to allow arm to allow the buckle arm to reach the axle.
11. The buckle adjustment knob also provides a means of adjusting chain tension.

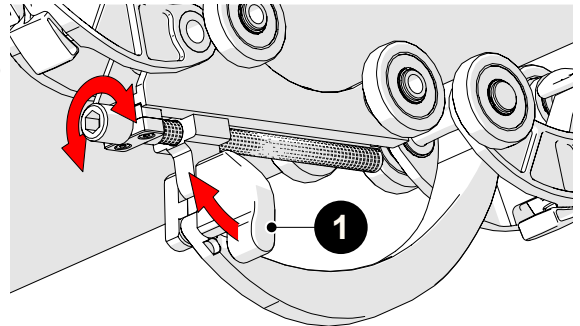

Fig. 196 - Adjust pressure of buckle

12. Rotate the buckle adjustment knob until the buckle's lever can be pushed down locking the buckle in place (Fig. 197).

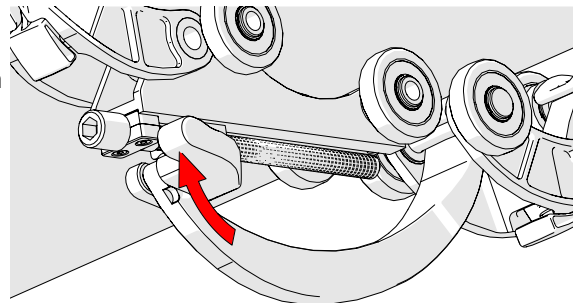

Fig. 197 - Press lever down to lock

13. Proper setup of the frame bar and probe holders is required (Fig. 198).

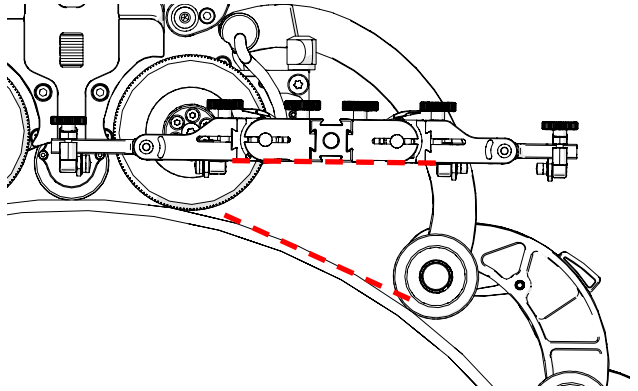

Fig. 198 - Incorrect swivel mount position

14. Release the swivel mount levers (Fig. 199) to pivot the swivel mount to a position parallel to the scan surface (Fig. 200) (see "Swivel Mount" on page 34 for additional details).

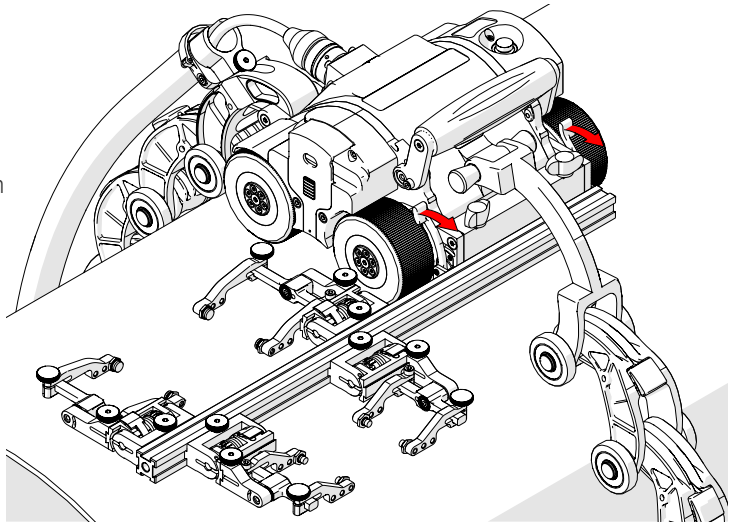

Fig. 199 - Release swivel mount levers

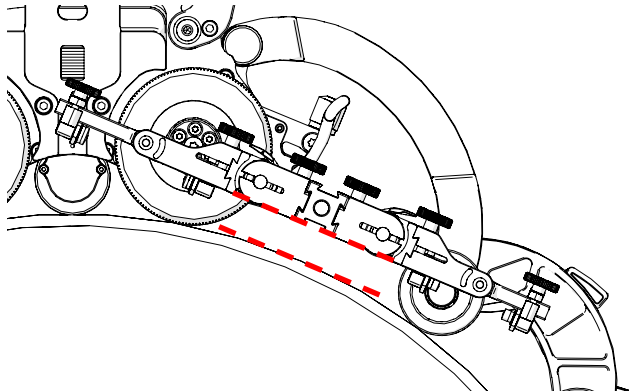

Fig. 200 - Correct swivel mount position

15. When the swivel mount is positioned appropriately, Lock the swivel mount levers (Fig. 201).

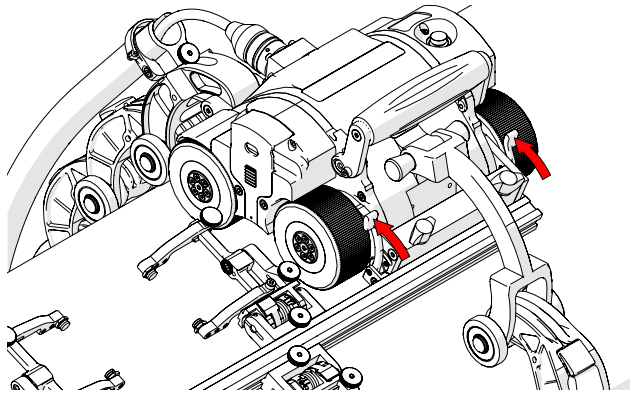

Fig. 201 - Lock swivel mount in place

16. Lower probe holders to the scan surface (see "Slip Joint Probe Holder" on page 25 for additional details).

6.2. System Startup

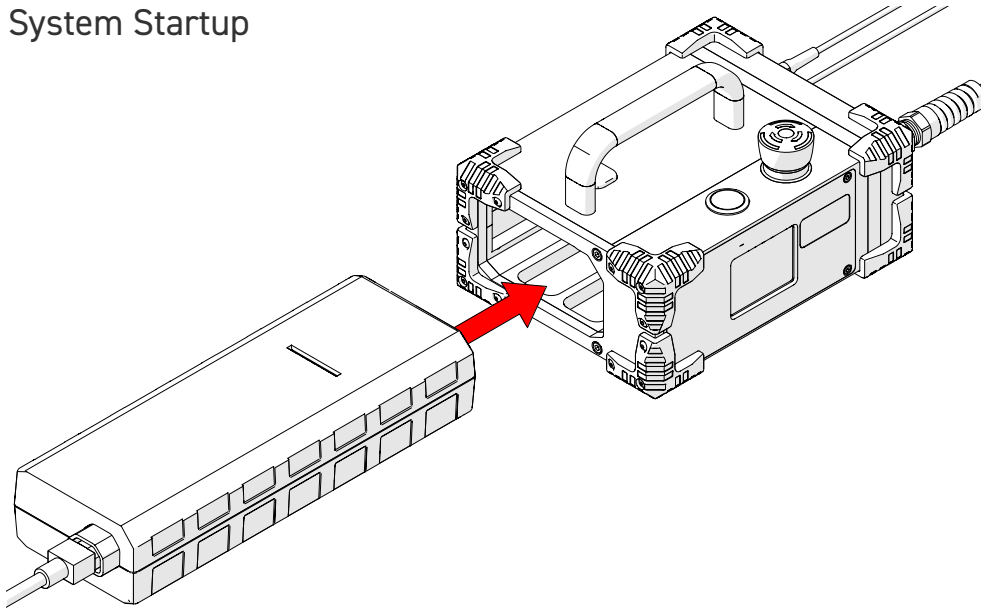

Fig. 202 - Insert power source

To activate the system, follow these steps:

1. Insert power source (Fig. 202) into power controller dock.
2. Connect the components (see "Configurations" on page 30).

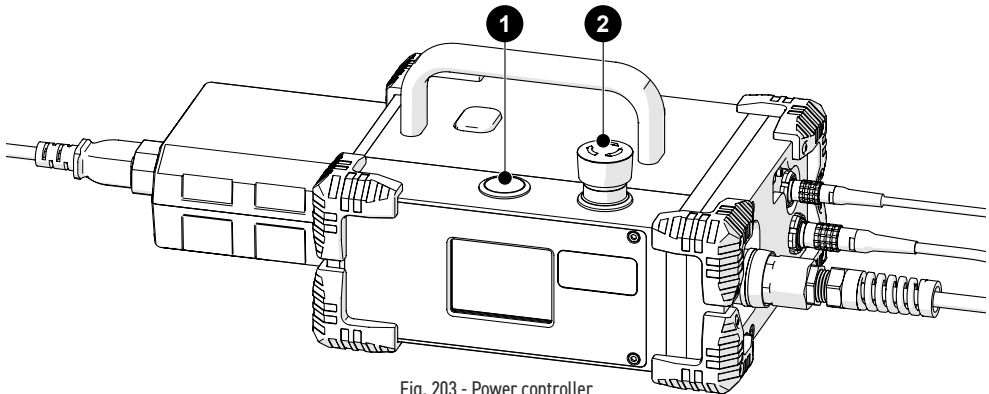

Fig. 203 - Power controller

3. Locate the **2** red emergency stop push button on the power controller. Rotate this button clockwise to unlatch (Fig. 203).
4. The **1** power button (Fig. 203) on the power controller activates the system.

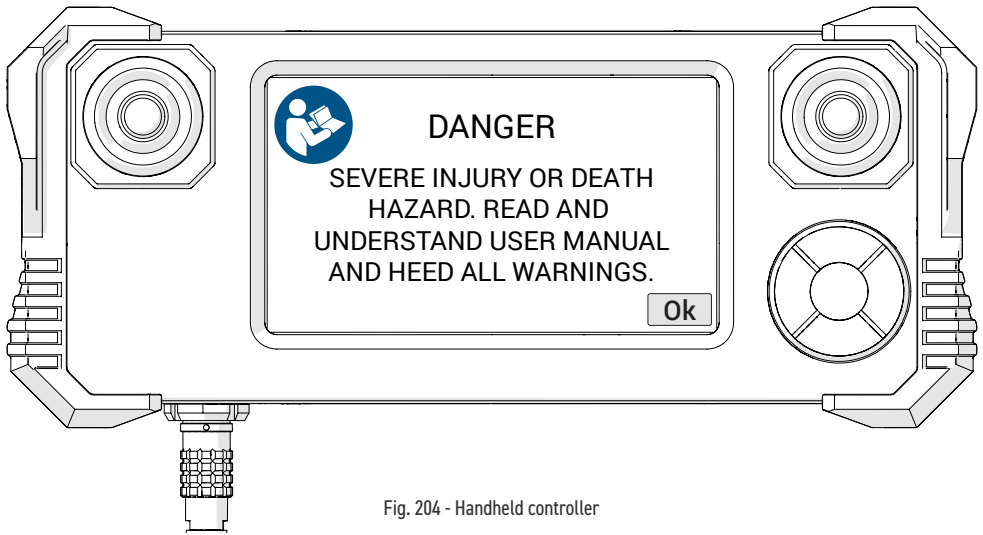

Fig. 204 - Handheld controller

5. A warning message will display on the handheld controller when power has been activated. Once the dangers of using the **MOTIX** are recognized and understood by reading this user manual, touch **Ok** to acknowledge the warning (*Fig. 204*).

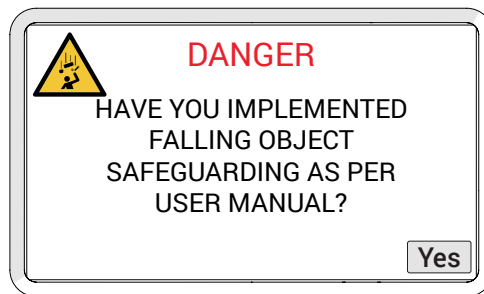

Fig. 205 - Falling object warning

6. A second warning message (*Fig. 205*) will display. Acknowledge this warning by touching **Yes**.

Once the system is initialized, the **Mode Select** screen will appear (*see "Mode Select Screen" on page 76*). The system is now ready for operation.

6.3. Operation

6.3.1. Handheld Controller Layout

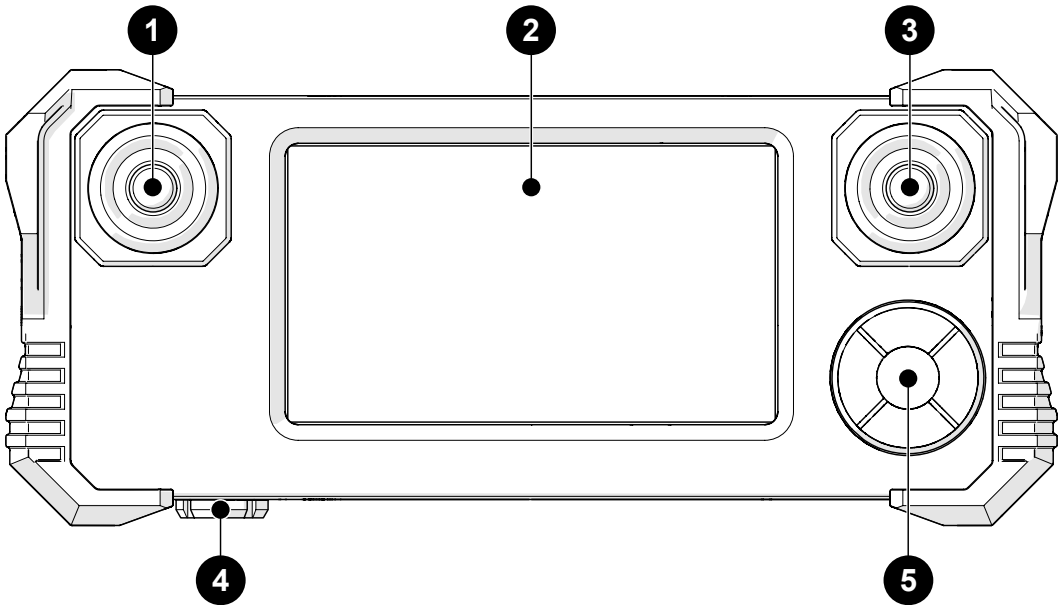

Fig. 206 - Handheld Controller

1	Steering/Raster joystick	(see "Joysticks" on page 75)
2	Touchscreen	(see "Touchscreen" on page 74)
3	Fwd/Rev joystick	(see "Joysticks" on page 75)
4	Controller cable connector	Connection point for the auxiliary cable.
5	D-pad	A means of navigating the on screen menus of the handheld controller.

6.3.1.1 Touchscreen

The **2** handheld controller's touchscreen is the primary operator interface for the system (Fig. 206). Buttons are indicated on-screen with a red border.

6.3.1.2 D-pad

The **5** D-pad (Fig. 206) provides a redundant system control that may be utilized as an alternative to the touchscreen. A blinking box around a button indicates the D-pad selection. Pressing the outer buttons of the D-pad selects

different buttons on-screen. Press the centre button of the D-pad to choose the button currently selected.

6.3.1.3 Joysticks

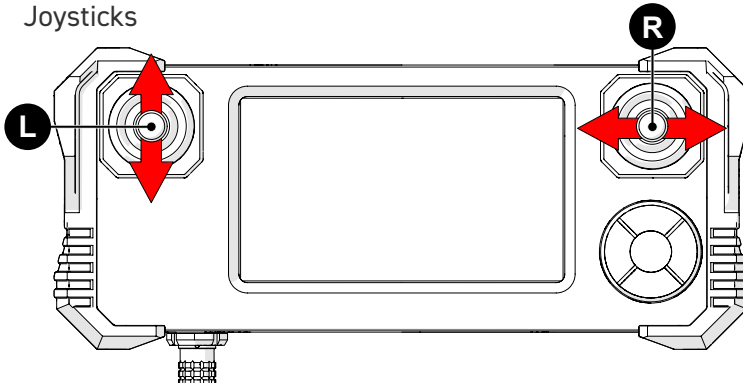

Fig. 207 - Handheld controller joysticks

The joysticks control system motion. The **L** left joystick controls the forward/reverse movement of the crawler. The **R** right joystick function is selected on screen. Functions include crawler steering or raster arm movement (Fig. 207).

6.3.2. Mode Select Screen

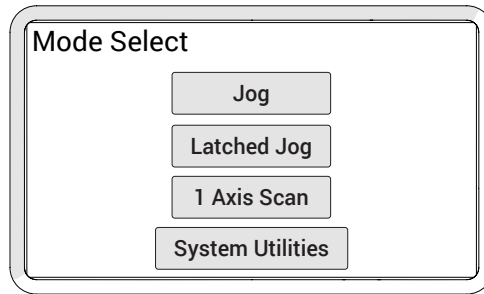

Fig. 208 - Mode select

The **Mode Select** screen offers four modes of operation for the system:

Jog Mode	(see "Jog Mode" on page 76)
Latched Jog Mode	(see "Latched Jog Mode" on page 78)
1 Axis Scan Mode	(see "1 Axis Scan Mode" on page 79)
System Utilities	(see "System Utilities Screen" on page 82)

6.3.3. Jog Mode

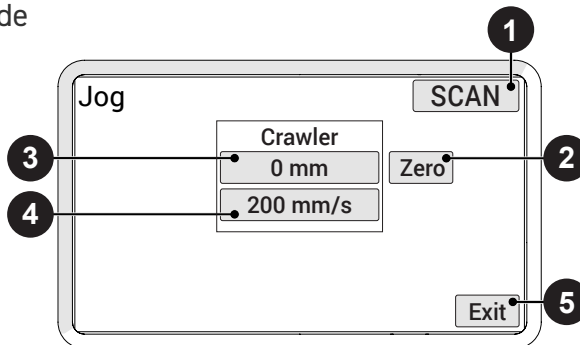

Fig. 209 - Button identification

Jog mode manually controls the system movement using the joysticks.

- 1 Scan/Rapid Button
(Fig. 209)

Used to quickly switch between crawler speeds. The speed in either mode can be manually set to the users preference. Rapid mode also changes the steering sensitivity according to the user settings.

TIP: Fine adjustments of speed and steering can be made in the User Settings (see "User Settings Screen" on page 83).

- 2 Zero Button Sets the current position to zero for all modules.
- 3 Module Position Button(s) Displays the current position of the crawler. Press to set the position to any value using the **Edit** screen. When a module position is modified, the position will be modified for all other system modes. When the right crawler module is connected, the crawler position displayed refers to the position of the auxiliary idler encoder which is located between the module's wheels.
- NOTE:** This function only zeroes the number displayed on the **MOTIX** handheld controller. It does not zero the position used in the data acquisition instrument.*
- 4 Module Rate Button(s) Displays the current maximum rate for the selected speed mode. Press to set the maximum rate using the **Edit** screen. The movement commanded by the joysticks will be limited to the indicated rate. When a rate is modified, the rate will be modified for all other system modes.
- 5 Exit Button Exits the jog mode and returns to the **Mode Select** screen.

6.3.4. Latched Jog Mode

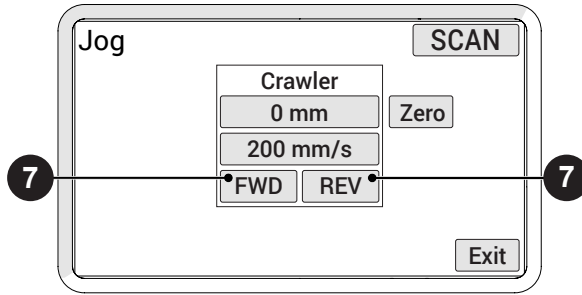

Fig. 210 - Latched jog mode

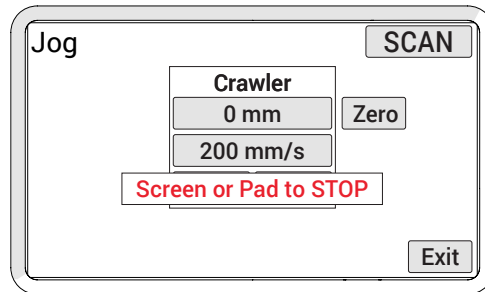

Fig. 211 - Latched jog stop screen

Identical to standard jog mode, latched jog mode adds forward or reverse crawler movement at the selected scan rate. This eliminates the need to manually hold the left joystick (see “Jog Mode” on page 76).

7 FWD & REV Buttons:

The **FWD** and **REV** buttons are located in the crawler tab. Press the **FWD** or **REV** button to drive the crawler at the current maximum scan rate. When the crawler is in motion, the steering joystick is still enabled. Touching the handheld controller screen or pressing the D-pad stops crawler movement.

NOTE: The **FWD** & **REV** Buttons will not be present in rapid mode.

6.3.5. 1 Axis Scan Mode

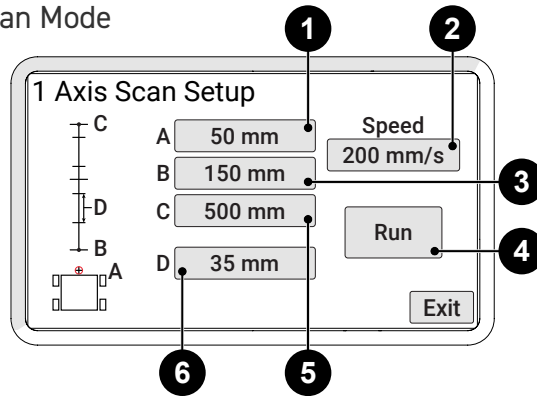

Fig. 212 - Scan mode

1 Axis Scan mode drives the crawler in a straight line, stopping at programmed intervals.

1	Point A	The current encoder position of the crawler.
2	Speed Button	Access the User Settings screen to set the crawler's scan speed.
3	Point B	The start point of the scan travel. The system will move the scanner from the A point to this point at the start of a scan.
4	Run Button	Enables the Scan screen (see "1 Axis Scan Screen" on page 80).
5	Point C	The finish point of the overall scan travel.
6	Setting D	The distance the system will advance.

The **Scan Setup** screen indicates the scan functions that may be entered. Each point and setting, **A**, **B**, **C**, **D**, corresponds to a coordinate entry button on the screen.

A typical scan begins at the **A** position and moves to the **B** position. Scanning begins at the **B** position and scans the distance of **D** until the **C** position is reached.

6.3.5.1 1 Axis Scan Screen

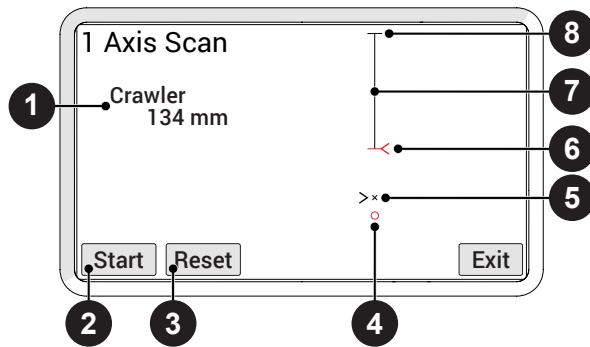

Fig. 213 - 1 Axis scan screen

The **1 Axis Scan** screen initiates and monitors the scan, and advances the set distance. The initial scan screen is an approximation of a full view (*zoomed out*) of the entire scan path.

<p>1 Crawler (Motor) (Fig. 213)</p>	<p>The current encoder position of the crawler. If an idler encoder is available, it will also indicate the encoder selected (<i>Motor or Idler</i>) for crawler positioning as set in the User Settings (see “<i>User Settings Screen</i>” on page 83).</p>
<p>2 Start/Stop button</p>	<p>Start or stop the scan sequence. When a scan has been stopped while in progress, the start button resumes the scan.</p>
<p>3 Reset</p>	<p>Return the scanner to the A position. Press the start button to begin the scan sequence from the initial setting.</p>
<p>4 Scan location</p>	<p>Small red circle indicates the A position.</p>
<p>5 Scanner position</p>	<p>The blinking cross hair indicates the current scanner position.</p>
<p>6 Next scanner position</p>	<p>Where the scanner will travel to next.</p>
<p>NOTE: The red indicator is always where the scanner will go next.</p>	
<p>7 Summary screen</p>	<p>A visual representation of the scan area.</p>
<p>8 End position</p>	<p>The completed distance of programmed travel.</p>

When Start is pressed the first time, the scanner will travel to point **B** and pause. The summary screen will show a closer view (*zoom in*) of the scan path.

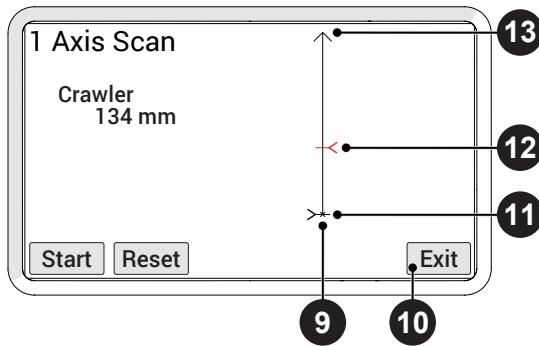

Fig. 214 - 1 Axis scan screen

9 Scanner location The current encoder position of the crawler.

10 Exit button

Pressing **Exit** stops all scanning motion. A warning appears when the scanner is not in the **A** position, (Fig. 215). The warning alerts that the **A** position of the scanner will be changed to the current position.

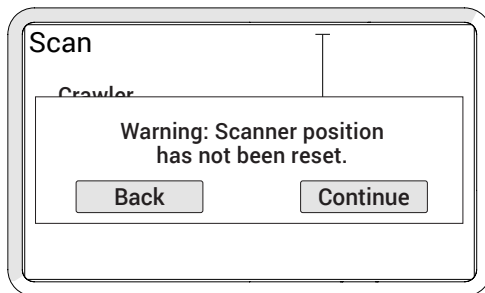

Fig. 215 - Exit warning

Press **Back** to return to the **1 Axis Scan** screen to reset the scanner and maintain the original **A** position. Press **Continue** to reset the **A** position and exit the **1 Axis Scan Setup** screen.

11 Scanner position

The blinking cross hairs indicate the scanner position.

12 Next scanner position

Where the scanner will travel next.

13 End point

Arrow indicates the travel will continue to advance. A straight line indicates the end of programmed travel.

6.3.6. System Utilities Screen

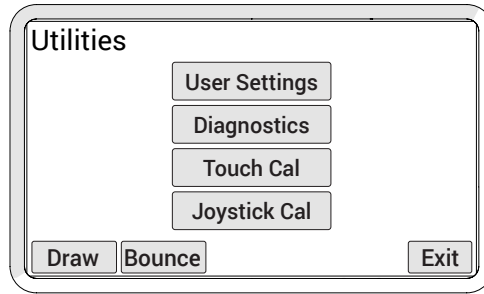

Fig. 216 - Utilities screen

The **Utilities** screen provides access to the setup, diagnostics and user preference settings.

User Settings Button (Fig. 216)	Access the User Settings screen, allowing for various user preferences to be adjusted.
Diagnostics Button	Enters the Diagnostic screens to monitor system components and function.
Touch Cal Button	Used to initiate the Touch Calibration screen.
Joystick Cal Button	Used to enter the Joystick Calibration screen.
Draw Button	Enters mode used to test the touchscreen accuracy and response.

6.3.6.1 User Settings Screen

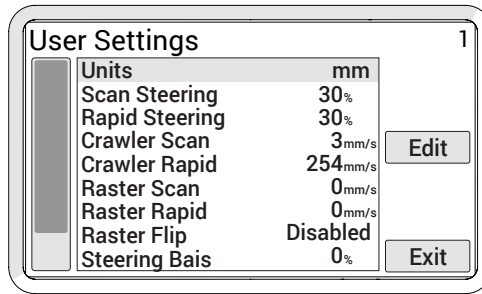

Fig. 217 - User settings screen

Allows the user to customize the system to their preferences.

The blinking highlighted box indicates the current selection. Use the D-pad or **Up** and **Down** buttons to select different settings.

Press **Edit** to enter the **Edit** screen to apply changes to the selected setting.

The **Exit** button directs to the **System Utilities** screen.

Title	Description	Valid Range	Default
Units	Changes the measurement units for display and user entry. When set to 0, units measure in inches. When set to 1, units measure in millimetres.	inches or mm	mm
Crawler Scan	Sets the crawler scan rate in the current units/second. This setting can also be changed through the Jog or Two Axis Scan Speed screens	0-254 mm/s (0-10 in/s)	76 mm/s (3.0 in/s)
Crawler Rapid	Sets the crawler rapid rate in the current units/second. This setting can also be changed through the Jog screen.	0-254 mm/s (0-10 in/s)	254 mm/s (10 in/s)
Display Brightness	Sets the brightness of the display.	0-100	100%
Scan by Idler Wheel	Choose the default encoder, the Idler wheel or the motor encoder.	Disabled or Enabled	Enabled

6.3.6.2 Diagnostics Screens

Several diagnostic screens allow various system functions to be monitored. Navigate to different diagnostic screens using the **PREV** and **NEXT** buttons. The **Exit** button returns to the **System Utilities** screen.

NOTE: The diagnostic information requires an in-depth understanding of the underlying technologies and programming in the system. Not all functions and information are explained in this manual.

6.3.6.2.1 Detected Modules

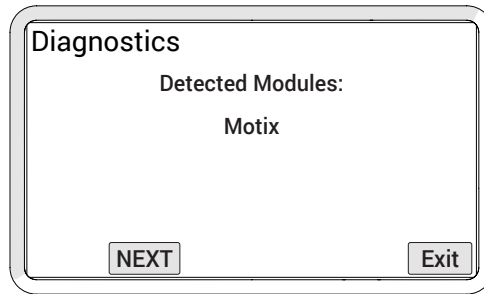

Fig. 218 - Detected modules screen

The screen indicates the system software version and displays which modules were detected when the system was activated.

6.3.6.2.2 System 1

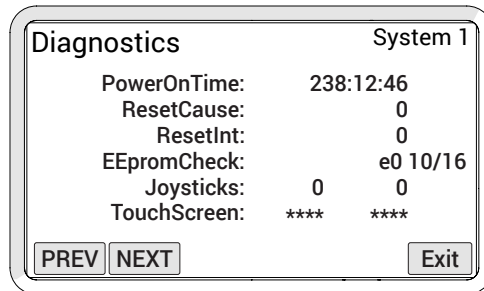

Fig. 219 - Diagnostic screen

System 1 diagnostic screen displays general system function information.

PowerOnTime	The total accumulative time the handheld controller has been powered
Joysticks	Indicates the raw position reading from the joysticks
TouchScreen	Indicates the raw position reading from the last touchscreen contact

6.3.6.2.3 System 2

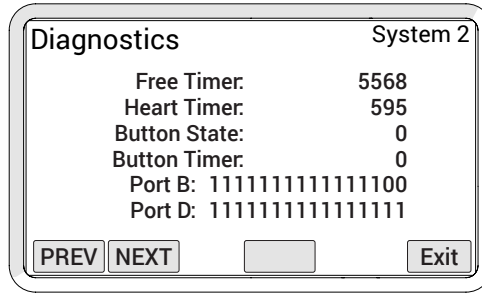

Fig. 220 - Diagnostic screen

Additional general system function information is displayed within the **System 2** screen. An empty button is provided to allow testing of the D-pad.

Free Timer	Value from a free running system timer. If this timer is static, an internal controller issue is present
Button State	Shows the state of the push buttons in the D-pad.
Button Timer	Shows the timer associated with the D-pad.

6.3.6.2.4 System 3

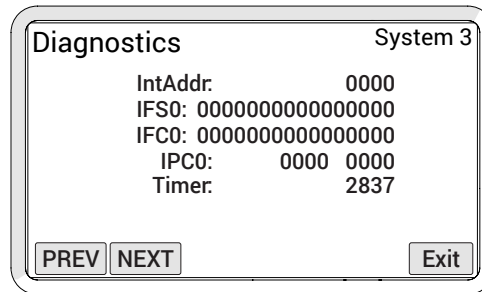

Fig. 221 - Diagnostic screen

The **System 3 Diagnostic** screen displays additional system information. The information provided does not typically assist the user.

6.3.6.2.5 Motix

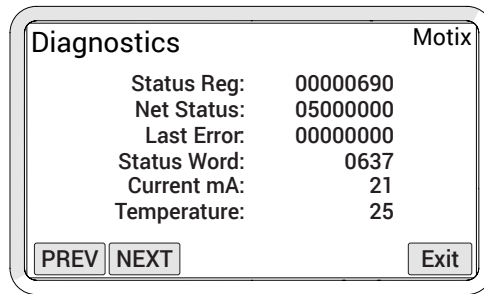

Fig. 222 - Diagnostic screen

The **Motix diagnostic** screens provide information regarding the status of each motorized module. A screen is available for these components if they are detected upon startup.

Current mA

Displays the output of the module to the motor. The current (*mA*) displayed is directly proportional to the motor's output torque. This reading can be used to check if the control system is responding to forces on the module's motor.

Temperature

Internal temperature reading of the module in degrees Celsius.

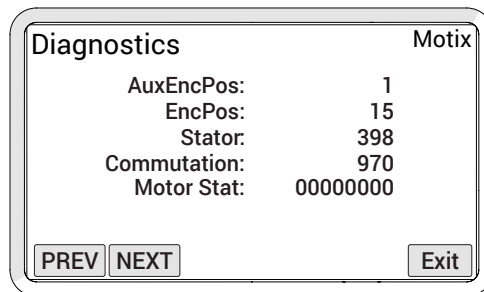

Fig. 223 - Diagnostic screen

AuxEncPos

Displays the position of the auxiliary encoder in counts when connected to the module. When the auxiliary encoder is moved, this number will change. When the encoder is moved from its current position and then back to that exact same position, this number will also return to its original position.

6.3.6.3 Touch Calibration Screen



Fig. 224 - Touch calibration screen

This option allows calibration of the touch screen. Typically, this should not be necessary.

Touch the screen as the markers appear in the four corners of the screen.

TIP: *It is recommended that the markers be touched with a small object to enhance the touch position accuracy during calibration.*

The new calibration is stored immediately when the fourth marker is pressed. The calibration utility exits and returns to the **System Utilities** screen. To abort the calibration, the system power may be turned off before the last marker is pressed.

6.3.6.4 Joystick Calibration Screen

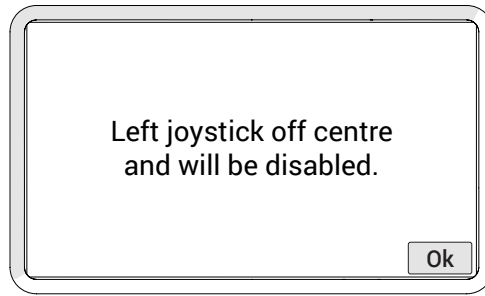

Fig. 225 - Joystick error

Typically, joystick calibration is only necessary when a joystick off-centre error is detected upon startup (Fig. 225). Calibration may also be used when a joystick function does not appear to be properly centred.

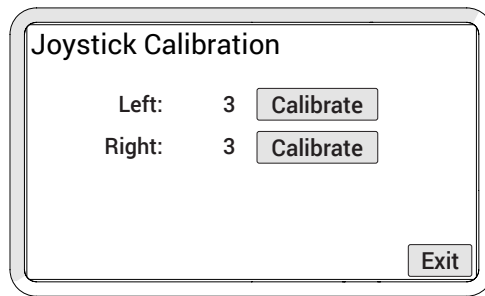

Fig. 226 - Joystick calibration screen

Current readings of the joysticks are displayed on the **Joystick Calibration** screen (Fig. 226). When the numbers are not near zero, press the **Calibrate** button to recalibrate to 0. The new calibration is stored when the **Exit** button is pressed.

6.3.6.5 Draw



Fig. 227 - Draw utility

The draw utility may be used to test the function of the touchscreen. Exit the utility by pressing the D-pad.

6.3.7. High Internal Temperature Screen



CAUTION! HOT SURFACE. The handles of the crawler and crawler body may be hot to the touch. Use appropriate protective equipment when removing a crawler from a high temperature surface.

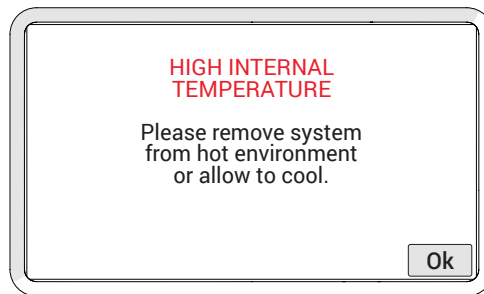

Fig. 228 - High internal temperature screen

When the system approaches its maximum operating temperature, the high internal temperature screen will display. When this alert screen is displayed, all motor and system functions will cease.

Press **OK** to reactivate the system to remove **MOTIX** from the scan surface.

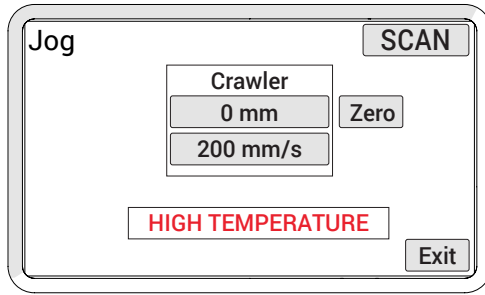

Fig. 229 - High internal temperature screen

Should the user choose to continue operating the crawler, the HIGH TEMPERATURE warning will continue to display until the temperature falls below the set temperature limit.

MAINTENANCE

7.1. Safety Precautions Before Maintenance



WARNING! ELECTRICAL SHOCK HAZARD. Disconnect the power controller when servicing the equipment. The power controller is powered even when the E-Stop push button is latched in the off position.

7.2. Cleaning

General cleaning of components is important to keep your system working well. All components that have no wiring or cables are completely waterproof. Components can be washed with warm water, dish soap and a medium bristle brush.

Before using the scanner, ensure all connectors are free of water and moisture.

NOTE: All components with wiring, cables or electrical connections are splashproof. However, these components are **NOT** submersible.

NOTE: Never use strong solvents or abrasive materials to clean your scanner components.

7.3. Maintenance Schedule

The **MOTIX** system must be maintained according to the following schedule:

Task	Frequency
<u>Inspect cables and connectors</u> Inspect the umbilical cable, the power controller cable and the power cable for damage. Have any damaged cable repaired by a qualified person or replace the cable assembly as necessary. Inspect all connectors for damage or moisture. Straighten bent pins. Dry connectors before using.	Every Use
<u>General cleaning</u> Ensure the scanner stays relatively clean by wiping off any excess dirt or other contaminants after every use.	Every Use

TROUBLESHOOTING

8.1. Startup Issues

Two messages are possible in the event of a startup issue: **Joystick Off Center** or **Checking Network**.

8.1.1. Joystick Off Center

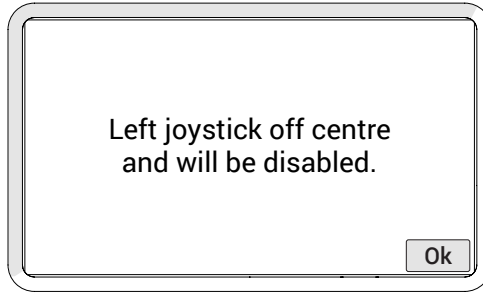

Fig. 230 - Joystick off centre screen

Upon system startup, the joystick positions are detected. When a joystick is detected outside the centre position, the **Joystick Off Center** screen displays, indicating the joystick will be disabled. Press **Ok** to continue system startup. All system functions will work normally, with the exception of movements that require joystick operation.

Ensure the handheld controller's joysticks are free of interference and reset the system power to enable joystick control.

If no interference of the joystick is present, the joystick calibration may need to be performed (see "Joystick Calibration Screen" on page 88)

8.1.2. Checking Network

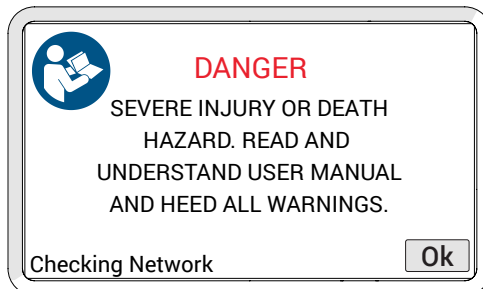

Fig. 231 - Checking network screen

During startup, the system initializes the communications to all the devices on

the network. If the network communication fails for any reason, the **Checking Network** message will appear and remain on screen.

Likely causes of this failure:

1. No devices connected to the network.
2. A problem with one of the devices.
3. Cable issue causing the entire network to fail.

Check the connections of the devices or try removing one device at a time from the system to isolate the problem device.

NOTE: Always turn off the system power before connecting or disconnecting any devices.

8.2. Startup Override

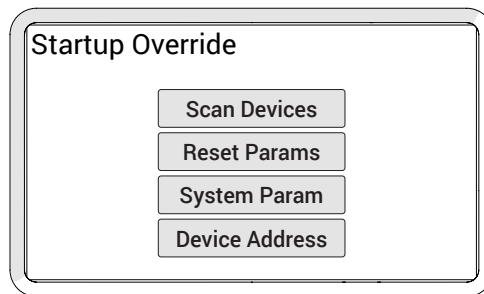

Fig. 232 - Startup override screen

A system maintenance mode may be accessed to correct system issues. Enter the maintenance mode by pressing the handheld controller D-pad while the system power is activated. Continue pressing the handheld controller D-pad until the **Startup Override** screen appears.

8.2.1. Scan Devices

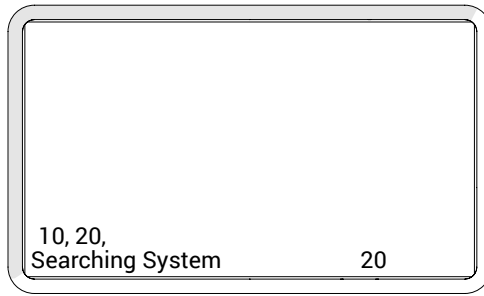

Fig. 233 - Searching System screen

This utility scans the system network for devices. All possible device addresses and speeds are scanned. As devices are found, the address of the device and speed are displayed. When the scanning is complete, power to the system must be cycled.

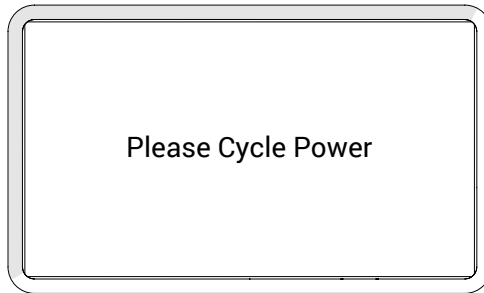

Fig. 234 - Cycle power screen

When a device is connected to the system but is not detected, this most likely indicates an internal device problem.

8.2.2. Reset Parameters

If the system parameters become corrupt or a change is made, that prevents the system from functioning properly. All system parameters may be restored to their factory settings by selecting this option. When pressing the **Reset Params** button, the changes occur immediately. Power will need to be cycled for the reset to be complete.

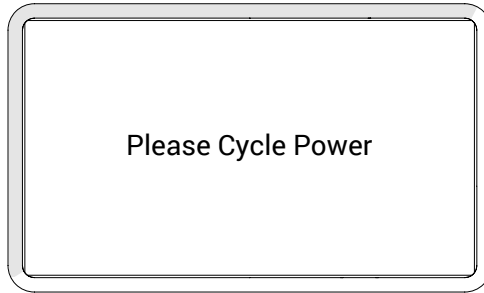

Fig. 235 - Cycle power screen

8.2.3. System Parameters

System parameters are factory set to control a variety of functions. These parameters can not be modified. However, special circumstances may occur when modification of these parameters could be recommended by the manufacturer.

Instructions for making changes to the system parameters will only be provided when deemed necessary by the manufacturer.

8.2.4. Device Address

Instructions for making changes to the system parameters will only be provided when deemed necessary by the manufacturer.

8.3. Additional Issues

Problem	Possible Cause	Solution
The handheld controller display does not activate.	Input power requirements not met.	Ensure input power meets requirements. <i>(see "Power Requirements" on page 5)</i>
	The handheld controller not plugged into umbilical.	Plug handheld controller into umbilical. Ensure connectors are dry, clean and connector pins are not bent.
	The umbilical cable is not properly connected.	Check umbilical cable connections at both ends. Ensure connectors are dry, clean and connector pins are not bent.
	MOTIX system not started.	Start the MOTIX system <i>(see "System Startup" on page 72)</i> .
The handheld controller display is activated, yet the crawler does not drive.	Damaged components in the handheld controller, crawler, power controller or cabling.	Contact manufacturer <i>(see "Jireh Industries Ltd." on page 1)</i> .
	The handheld controller is not in the correct mode for driving.	<i>(see "Mode Select Screen" on page 76 for additional details)</i> .
	Damaged components in the handheld controller, crawler, power controller or cabling.	Contact manufacturer <i>(see "Jireh Industries Ltd." on page 1)</i> .

SERVICE AND REPAIR



WARNING! ELECTRICAL SHOCK HAZARD. Disconnect the power controller when servicing the equipment. The power controller is powered even when the E-Stop push button is latched in the off position.



WARNING! DO NOT DISASSEMBLE. No user-serviceable parts. Disassembling any of the components in this product, beyond the instructions in this user manual, could void the regulatory certifications and/or effect the safety of the product.

9.1. Technical Support

For technical support, contact Jireh Industries (see “Jireh Industries Ltd.” on page 1).

SPARE PARTS

To order accessories or replacement parts for your **MOTIX** system (contact Jireh Industries Ltd. on page 1).

NOTE: These drawings are for parts order. This is not a list of kit contents.

10.1. Crawler

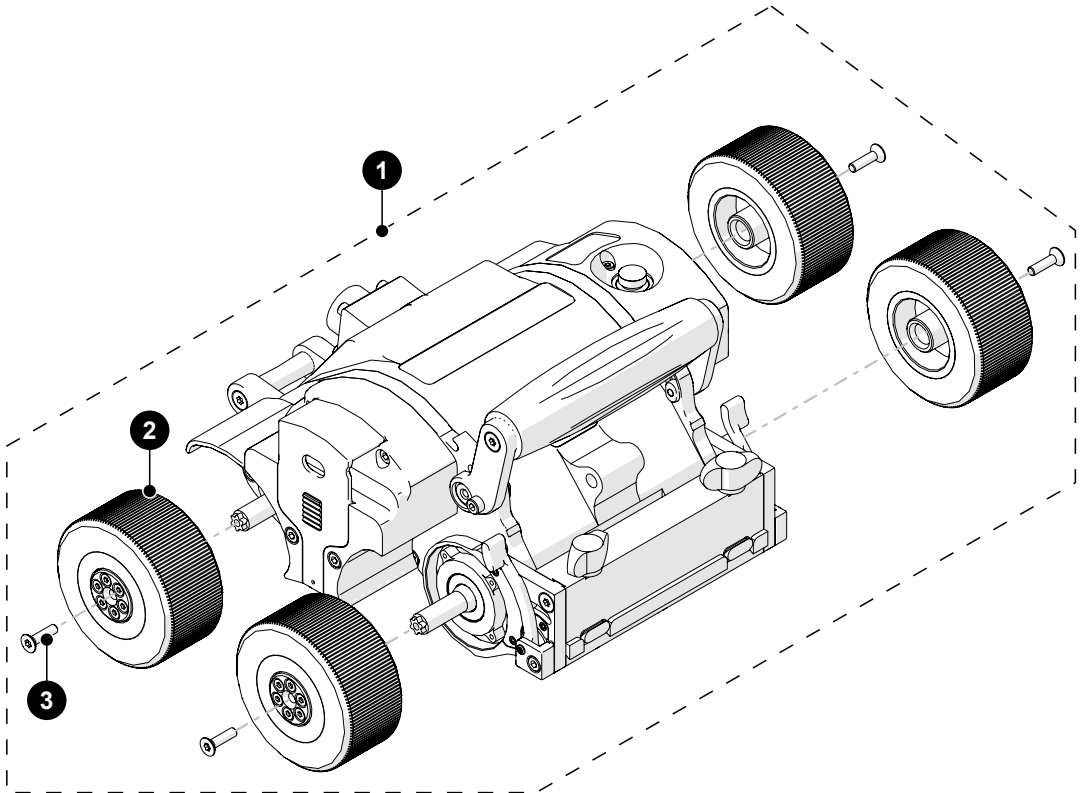

Fig. 236 - Crawler parts

BOM ID	Part #	Description
1	EJA003	MOTIX crawler
2	EJS009	MOTIX wheel
3	MD400-016	FHCS-TX, M4x0.7 X 16 mm

10.2. Kit Components

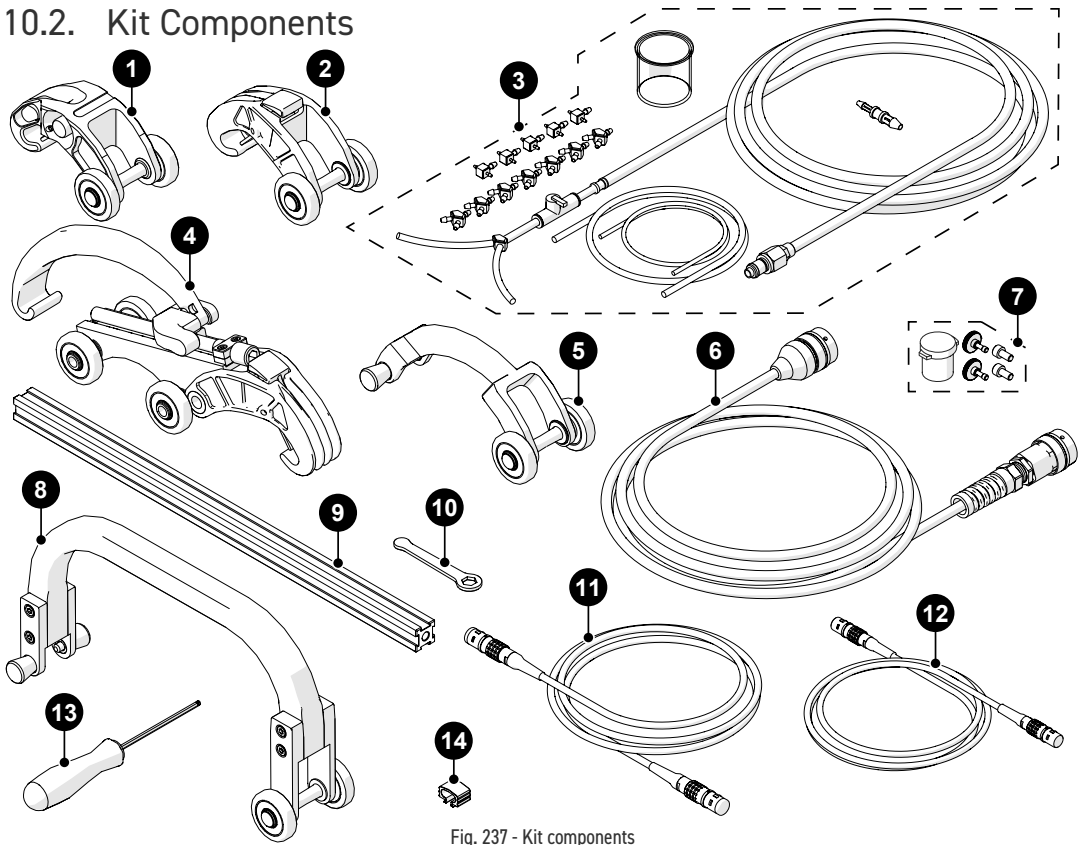

Fig. 237 - Kit components

BOM ID	Part #	Description
1	EES011	Dovetail link
2	EES004	Short link
3	CMG009-	Irrigation kit, 2-4 probe, large tube (<i>various lengths available</i>)
4	EES014	Buckle
5	EJS013	Standard overtop link
6	UMA022-	Umbilical (<i>various lengths available</i>)
7	PHG014	Probe holder spare parts kit, 2 probe
8	EJS014	Large overtop link
9	BG0038-45	Frame bar, 45 cm (<i>see Frame Bars</i>)
10	EA470	10 mm ($3/8$ in) wrench
11	UMA025-	J300 Encoder cable, 5 m (16.4 ft) (<i>see Encoder Connector Type</i>)
12	UMA017-06	Auxiliary cable

13 EA414 3 mm (0.118 in) hex driver

14 BG0091 Cable clip

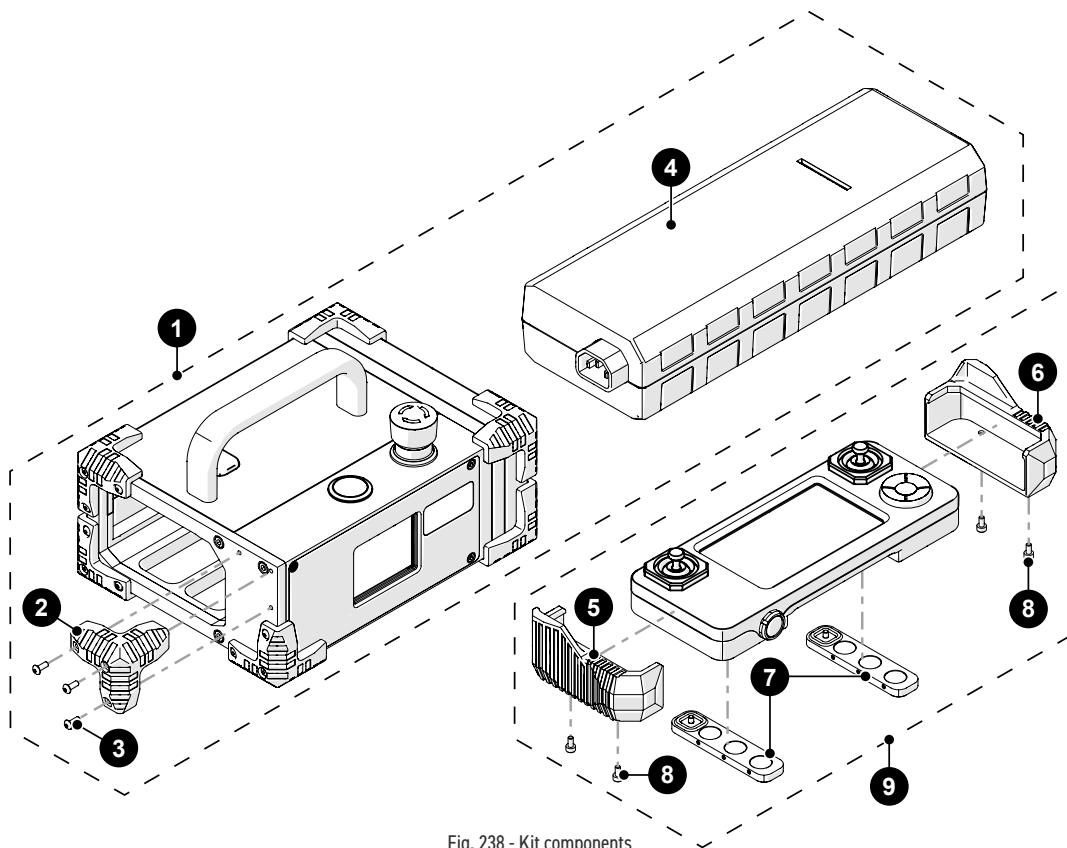

Fig. 238 - Kit components

BOM ID	Part #	Description
1	CXA040-	Power controller (see Power Cord Type)
2	DY0011	Rubber bumper
3	MD072-008	BHCS, M3x0.5 X 8mm, SST
4	CXS122	Power supply
5	DM0067-L	Handheld controller bumper (left)
6	DM0067-R	Handheld controller bumper (right)
7	DMS005	Handheld controller magnet holder
8	MD049-006	SHCS, M3x0.5 X 6mm, SST
9	DMA006	Handheld controller

10.2.1. Encoder Connector Type

Connector Type	Company/Instrument	Connector Type	Company/Instrument
B	Olympus OmniScan MX Zetec Topaz	G	Sonotron Isonic 25xx
C	Olympus Focus LT Zetec Z-Scan Eddyfi Ectane 2	U	Sonatest Veo / Prisma
E	Olympus OmniScan SX/MX2/X3 M2M MANTIS/GEKKO LEMO	V	Pragma PAUT
F	TD (<i>Technology Design</i>)	AD	Sonatest Veo / Prisma - Single Axis

NOTE: Additional encoder connector types are available.
(contact Jireh Industries Ltd. on page 1)

10.2.2. Power Cord Type

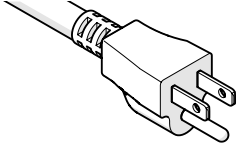
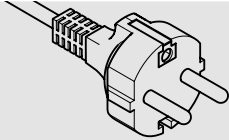
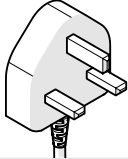
Connector Type	Part #	Power Cord	
N	SL032	North American	
E	SL039	European	
U	SL059	United Kingdom	
Z		No Cord	

10.2.3. Cable Management, Dovetail Mount

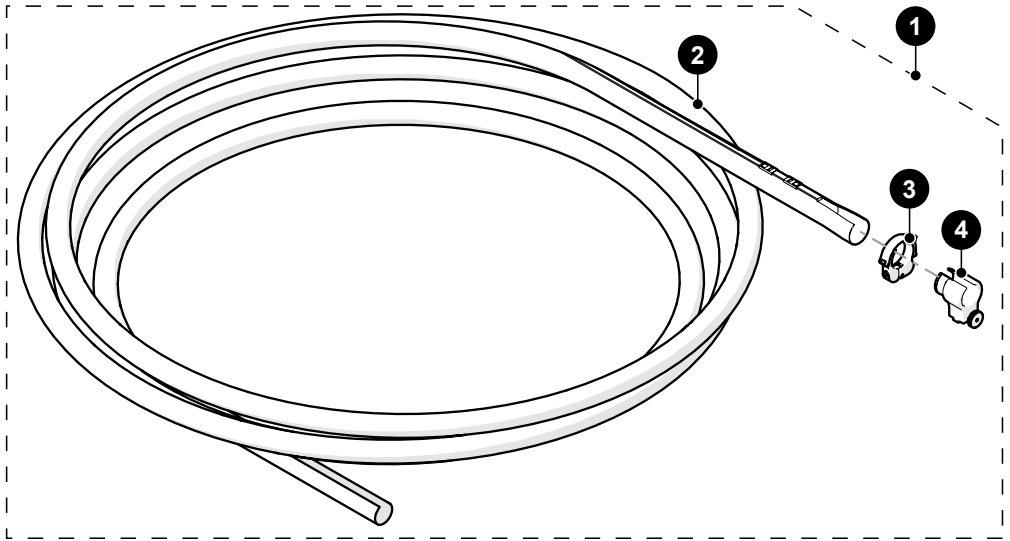
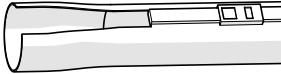
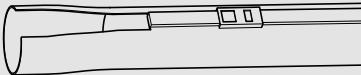
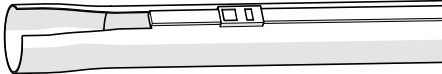
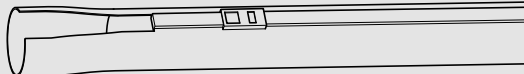

Fig. 239 - Cable management

BOM ID	Part #	Description
1	CES044-	Cable management: dovetail mount
2		<i>see Cable Management Sleeving</i>
3	CES066	Cable management clamp
4	CES067	Cable management mount, dovetail mount

10.2.4. Cable Management Sleeving

Length	Part #	Description	
04.5	CX0141	4.5 m (14.8 ft)	
09.5	CX0145	9.5 m (31.2 ft)	
14.5	CX0146	14.5 m (47.6 ft)	
29.5	CX0147	29.5 m (96.8 ft)	

10.3. Slip Joint Probe Holder Parts

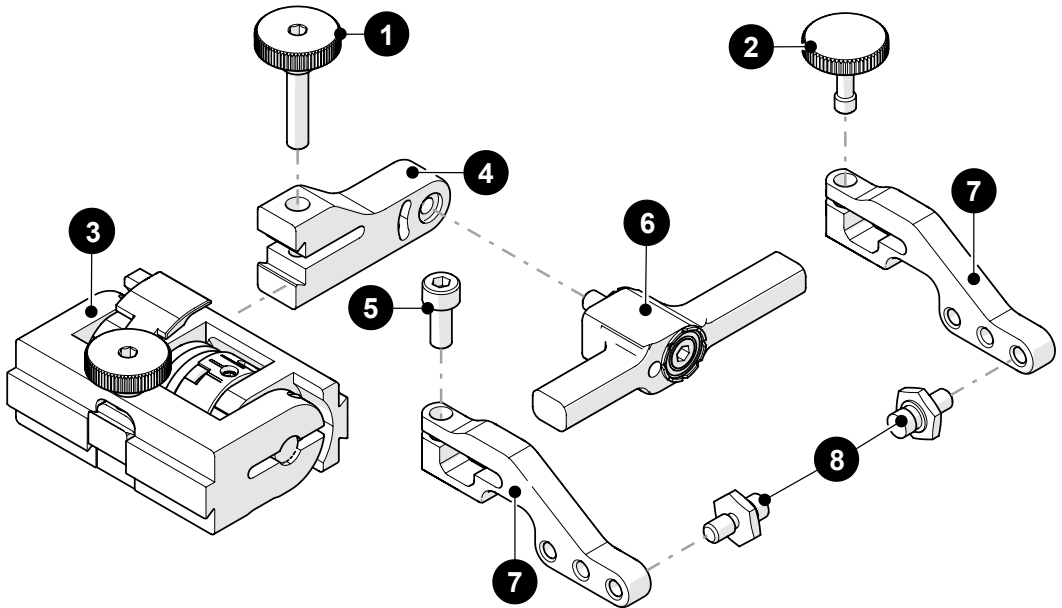

BOM ID	Part #	Description
1	PH0104	Knurled Knob, M4 x 0.7 x 18 mm, 4 mm stand off, SST
2	PH0082	Knurled Knob, M4 x 0.7 x 10 mm, 3 mm stand off, SST
3	PHS022	Slip Joint Probe Holder Subassembly
4	<i>see Swing Arm Style</i>	
5	MD050-010	SHCS, M4 x 0.7 x 10 mm, SST
6	<i>see Yoke Style</i>	
7	<i>see Arm Style</i>	
8	PH0011-X	Pivot Button Style (<i>see Pivot Button Style</i>)

Fig. 240 - Slip joint probe holder parts

10.4. Vertical Probe Holder Parts

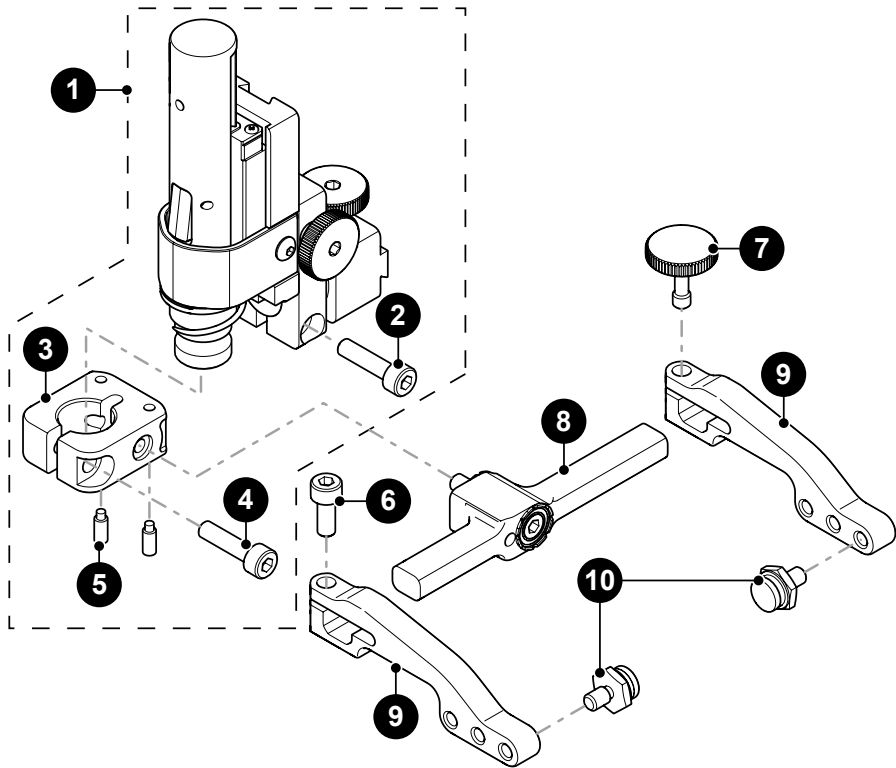

BOM ID	Part #	Description
1	PHS028	Vertical Probe Holder Subassembly
2	MA307	Screw, M4x16 mm High Strength SST SHCS
3	PH0087	Vertical Probe Holder Base
4	MD050-016	SHCS, M4 x 0.7 x 16 mm, SST
5	MA096	Screw, M3x8 mm Dog Point Set, SST
6	MD050-010	SHCS, M4 x 0.7 x 10 mm, SST
7	PH0082	Knurled Knob, M4 x 0.7 x 10 mm, 3 mm stand off, SST
8	see Yoke Style	
9	see Arm Style	
10	PH0011-X	Pivot Button Style (see Pivot Button Style)

Fig. 241 - Vertical probe holder parts

10.5. Heavy Duty Vertical Probe Holder

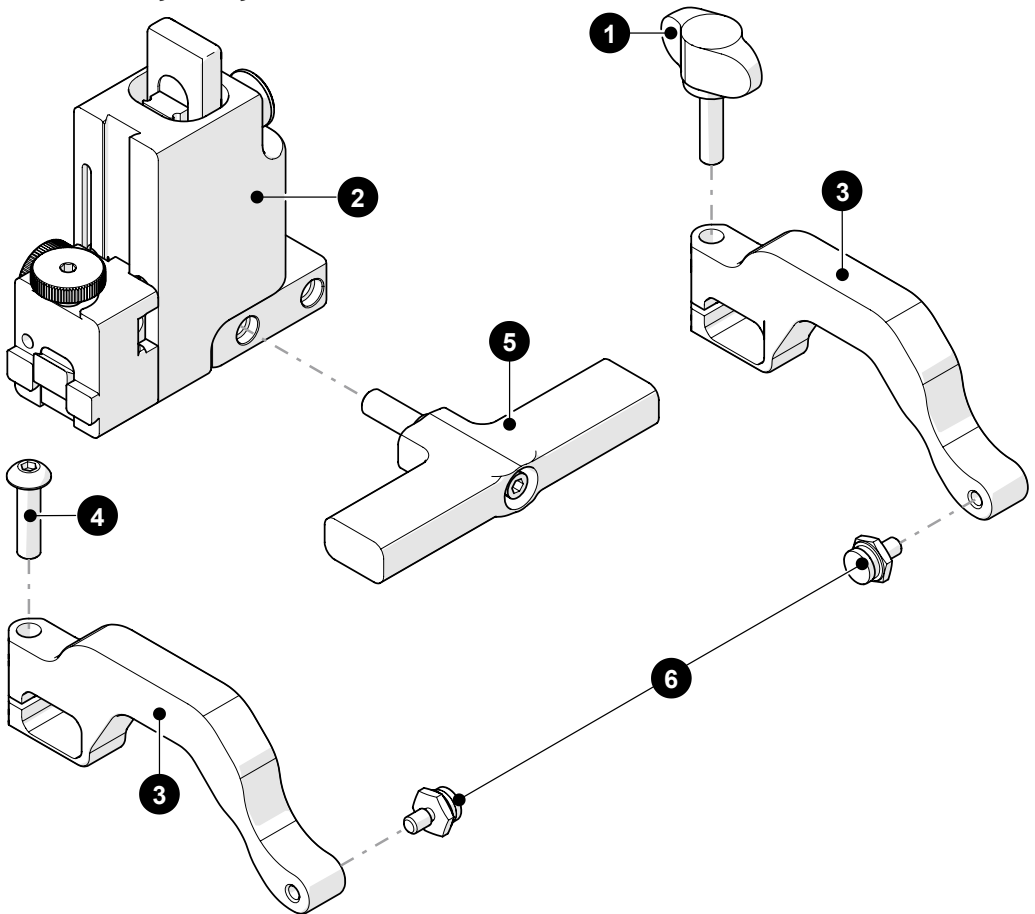

BOM ID	Part #	Description
1	EA154	Probe Holder Arm Adjustment Knob
2	PHS049	Heavy Duty Probe Holder Subassembly
3	PH0165	Heavy Duty Probe Holder Arm, Standard, Drop
4	MD074-020	BHCS, M5 x 0.8 x 20 mm, SST
5		See Heavy Duty Yoke Style
6	PH0011-X	Pivot Button Style (See Pivot Button Style)

Fig. 242 - Heavy duty vertical probe holder parts

10.5.1. Probe Holder Components

10.5.2. Arm Style









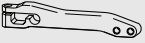

Arm Style	Part #		Arm Style	Part #	
A Standard, Flat	PH0090		B Short, Flat	PH0089	
C Long, Flat	PH0099		D Standard, Drop	PH0093	
E Short, Drop	PH0092		F Long, Drop	PH0094	
G Standard, Extra-Drop	PH0096		H Short, Extra-Drop	PH0095	
I Extra-Short, Flat	PH0159		J Extra-Short, Drop	PH0161	

Fig. 243 - Probe holder arm selection

10.5.3. Yoke Style

Yoke Style	Part #	Length		Yoke Style	Part #	Length	
S Standard	PHS052	6.3 cm (2.47 in)		W Wide	PHS063	7.9 cm (3.06 in)	

Fig. 244 - Probe holder yoke selection

10.5.4. Swing Arm Style

Swing Arm Style	Part #	Length		Swing Arm Style	Part #	Length	
Short	PH0069	4.1 cm (1.61 in)		Long	PH0100	4.6 cm (1.81 in)	

Fig. 245 - Swing arm selection

NOTE: Short swing arm only compatible with standard yoke style.

10.5.5. Heavy Duty Yoke Style

Yoke Style	Part #	Length		Yoke Style	Part #	Length	
S Standard	PHS048	8.3 cm (3.26 in)		W Wide	PHS047	12.2 cm (4.79 in)	

Fig. 246 - Heavy duty yoke selection

10.5.6. Pivot Button Style











	Pivot Hole Size	Wedge Type			Pivot Hole Size	Wedge Type	
01	8.0 mm (0.315 in)	Olympus PA		02	5.0 mm (0.197 in)	Olympus TOFD	
03	2.7 mm (0.106 in)	Sonatest DAAH PA		04	9.5 mm (0.375 in)	-	
06	3.0 mm (0.118 in)	-		07	2.3 mm (0.09 in)	-	
08	Conical Head	-		09	5 mm (0.197 in) Internal	Zetec PA/TOFD	
11	3 mm (0.118 in) Internal	-		14	4 mm (0.157 in)	-	

Fig. 247 - Pivot button selection

NOTE: Additional probe holder pivot button types are available.
(contact Jireh Industries Ltd. on page 1)

10.6. Variable Components

10.6.1. Frame Bar











Part #	Length		Part #	Length	
BG0038-05	5 cm (1.97 in)		BG0038-10	10 cm (3.94 in)	
BG0038-15	15 cm (5.91 in)		BG0038-20	20 cm (7.87 in)	
BG0038-25	25 cm (9.84 in)		BG0038-30	30 cm (11.81 in)	
BG0038-35	35 cm (13.78 in)		BG0038-40	40 cm (15.75 in)	
BG0038-45	45 cm (17.72 in)		BG0038-50	50 cm (19.69 in)	
BG0038-55	55 cm (21.65 in)				

Fig. 248 - Frame bar selection

10.7. Accessories

10.7.1. Preamp Bracket

Part #	Description
CES029	Preamp Bracket
CES029-V	Preamp Bracket with Velcro

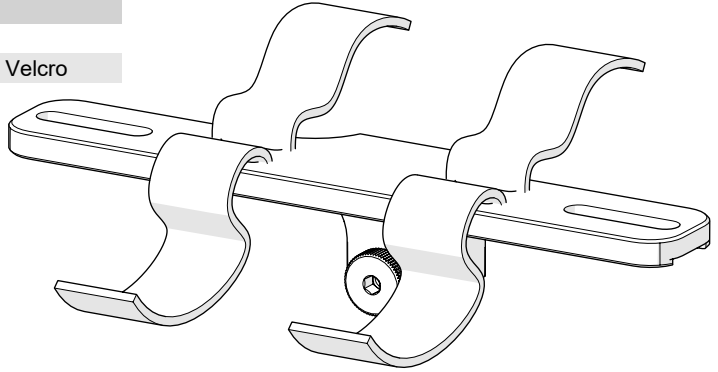
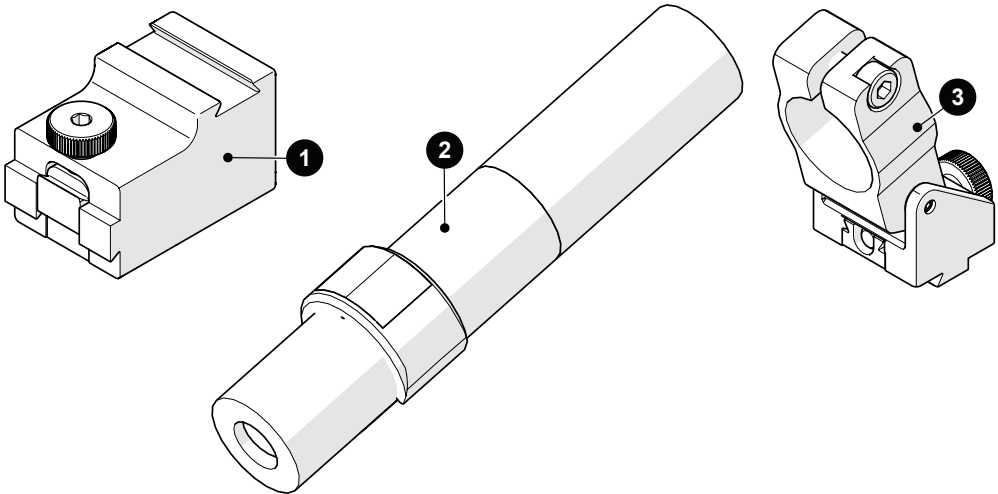

Fig. 249 - Preamp bracket

10.7.2. Battery Powered Optical Guide



BOM ID	Part #	Description
1	BGS068	Perpendicular Dovetail Mount
2	JV024	Line Laser, Battery Powered, Class 1
3	CXS082	Optical Guide Clamp

Fig. 250 - Battery powered optical guide

10.8. Cases

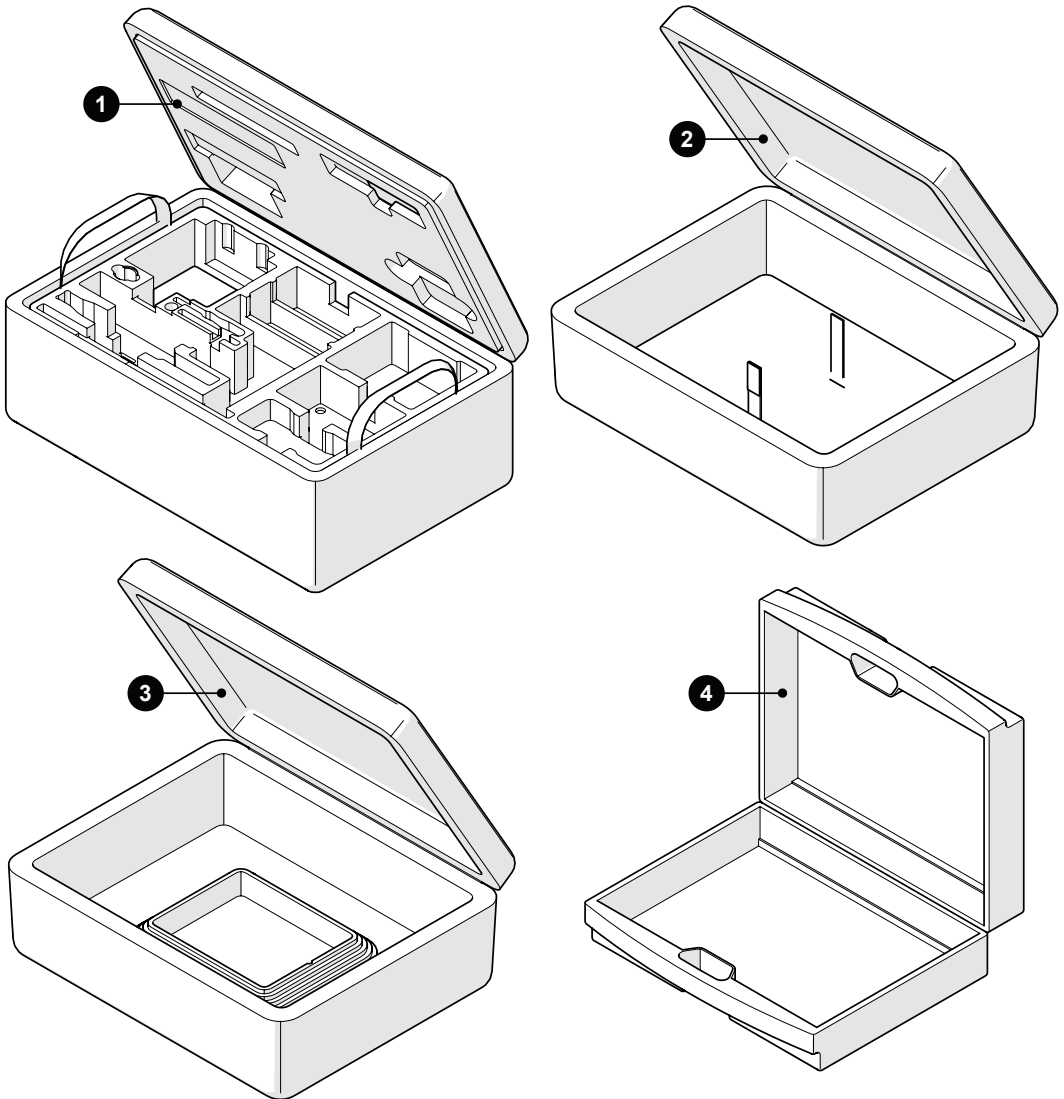

BOM ID	Part #	Description
1	EJA004	MOTIX Case
2	CXA023	Umbilical / Probe Holder Frame Case
3	CMA016	Motorized Pump / Umbilical Case
4	EA421	Umbilical Case

Fig. 251 - Carrying cases

DISPOSAL

WEEE Directive

In accordance with European Directive on Waste Electrical and Electronic Equipment (WEEE), this symbol indicates that the product must not be disposed of as unsorted municipal waste, but should be collected separately. Refer to Jireh Industries for return and/or collection systems available in your country.



LIMITED WARRANTY

WARRANTY COVERAGE

Jireh Industries warranty obligations are limited to the terms set forth below: Jireh Industries Ltd. (“Jireh”) warrants this hardware product against defects in materials and workmanship for a period of THREE (3) YEARS from the original date of purchase. If a defect exists, at its option Jireh will (1) repair the product at no charge, using new or refurbished replacement parts, (2) exchange the product with a product that is new or which has been manufactured from new or serviceable used parts and is at least functionally equivalent to the original product, or (3) refund the purchase price of the product. A replacement product/part assumes the remaining warranty of the original product or ninety (90) days from the date of replacement or repair, whichever provides longer coverage for you. When a product or part is exchanged, any replacement item becomes your property and the replaced item becomes Jireh’s property. When a refund is given, your product becomes Jireh’s property.

OBTAINING WARRANTY SERVICE

To utilize Jireh’s warranty service you must ship the product, at your expense, to and from Jireh Industries. Before you deliver your product for warranty service you must phone Jireh and obtain an RMA number. This number will be used to process and track your product. Jireh is not responsible for any damage incurred during transit.

EXCLUSIONS AND LIMITATIONS

This Limited Warranty applies only to hardware products manufactured by or for Jireh Industries. This warranty does not apply: (a) to damage caused by accident, abuse, misuse, misapplication, or non-Jireh products; (b) to damage caused by service (including upgrades and expansions) performed by anyone who is not a Jireh Authorized Service Provider; (c) to a product or a part that has been modified without the written permission of Jireh.

Jireh Industries Ltd.
53158 Range Road 224
Ardrossan AB T8E 2K4
Canada

Phone: 780-922-4534

jireh.com

HydroFORM™ is a trademark of Olympus.

All brands are trademarks or registered trademarks of their respective owners and third-party entities.

Changes or modifications to this unit or accessories not expressly approved by the party responsible for compliance could void the user's authority to operate the equipment.

All specifications are subject to change without notice.

© 2022-2023 Jireh Industries Ltd.

APPENDIX

13.1. MOTIX Setup Chart

MOTIX	PIPE OD RANGE with Large Overtop Link					PIPE OD RANGE with Standard Overtop Link				
	MIN (in)	MAX (in)	MIN (mm)	MAX (mm)	# OF SHORT LINKS*	MIN (in)	MAX (in)	MIN (mm)	MAX (mm)	# OF SHORT LINKS
	8.0	9.1	203	231	2	6.0	7.3	152	185	2
	9.0	10.3	229	262	3	7.1	8.5	180	216	3
	10.1	11.4	257	290	4	8.5	9.8	216	249	4
	11.2	12.5	284	318	5	9.7	11.0	246	279	5
	12.4	13.7	315	348	6	10.8	12.2	274	310	6
	13.6	14.9	345	378	7	12.0	13.3	305	338	7
	14.7	16.0	373	406	8	13.1	14.5	333	368	8
	15.8	17.1	401	434	9	14.3	15.6	363	396	9
	16.9	18.2	429	462	10	15.4	16.8	391	427	10
	18.0	19.4	457	493	11	16.6	17.9	422	455	11
	19.2	20.5	488	521	12	17.7	19.0	450	483	12
	20.3	21.6	516	549	13	18.8	20.1	478	511	13
	21.4	22.7	544	577	14	19.9	21.2	505	538	14
	22.5	23.8	572	605	15	21.0	22.3	533	566	15
	23.6	24.9	599	632	16	22.2	23.4	564	594	16
	24.7	26.0	627	660	17	23.2	24.5	589	622	17
	25.8	27.1	655	688	18	24.3	25.6	617	650	18
	26.9	28.2	683	716	19	25.4	26.7	645	678	19
	28.0	29.3	711	744	20	26.5	27.8	673	706	20
	29.0	30.4	737	772	21	27.6	28.9	701	734	21
	30.1	31.5	765	800	22	28.7	30.0	729	762	22
	31.2	32.6	792	828	23	29.8	31.1	757	790	23
	32.3	33.6	820	853	24	30.9	32.2	785	818	24
	33.4	34.7	848	881	25	32.0	33.3	813	846	25
	34.5	35.8	876	909	26	33.0	34.4	838	874	26
	35.6	36.9	904	937	27	34.1	35.5	866	902	27
	36.7	38.0	932	965	28	35.2	36.6	894	930	28
	37.8	39.1	960	993	29	36.3	37.6	922	955	29
	38.8	40.2	986	1021	30	37.4	38.7	950	983	30
	39.9	41.3	1013	1049	31	38.5	39.8	978	1011	31
	41.0	42.3	1041	1074	32	39.6	40.9	1006	1039	32
	42.1	43.4	1069	1103	33	40.6	42.0	1031	1067	33
	43.2	44.5	1097	1130	34	41.7	43.1	1059	1095	34



LARGE OVERTOP LINK
EJS014



STANDARD OVERTOP LINK
EJS013

* Short links include the dovetail link.

EJ0019 Rev 00



Jireh Industries Ltd.
53158 Range Road 224
Ardrossan, Alberta
Canada
T8E 2K4

780-922-4534

jireh.com