

An exploded view diagram of a battery assembly. The diagram shows a battery pack at the bottom, a battery tray in the middle, and a battery cover at the top. The battery pack is a rectangular unit with a textured surface. The battery tray is a flat, rectangular plate with a central slot for the battery pack. The battery cover is a large, rectangular panel with a recessed area for the battery tray. The diagram uses white lines on a dark gray background to show the components and their relative positions.

## **BATTERY**

DV0013 Rev 02

Battery and Charging System

## SAFETY WARNINGS / PRECAUTIONS

### KEEP THIS MANUAL – DO NOT LOSE

THIS MANUAL IS PART OF THE **BATTERY AND CHARGER SYSTEM** AND MUST BE RETAINED FOR THE LIFE OF THE PRODUCT. PASS ON TO SUBSEQUENT OWNERS.

Ensure any amendments are incorporated with this document.



**CAUTION!** The Battery and Charger is designed for a specific use. Using the Battery and Charger outside of its intended use is dangerous. Failure to comply with the warnings, instructions, and specifications in this manual could result in **PERSONAL INJURY** or **EQUIPMENT DAMAGE**. Read and understand this manual before using.



**WARNING!** Read and follow all instructions and labeling. Failure to follow instructions, including all warnings and cautions, could lead to misuse of the device or device malfunction.



**WARNING! DO NOT DISASSEMBLE.** No user-serviceable parts. Disassembling any of the components in this product, beyond the instructions in this user manual, could void the regulatory certifications and/or effect the safety of the product.



The WEEE symbol indicates that the product must not be disposed of as unsorted municipal waste, but should be collected separately.

*(see “Disposal” on page 25 for additional details).*

---

# TABLE OF CONTENTS

<b>1</b>	Identification .....	<b>1</b>
	1.1. Product Brand .....	1
	1.2. Manufacturer .....	1
	1.3. Compliance Declarations .....	1
	1.3.1. ISED Emissions Compliance (Canada).....	1
	1.3.2. FCC Suppliers Declaration of Conformity (United States).....	1
	1.3.3. European Union CE Declaration .....	2

<b>2</b>	Product Specifications .....	<b>3</b>
	2.1. Intended Use .....	3
	2.2. Storage Conditions.....	3
	2.2.1. Humidity .....	3
	2.2.2. Temperature .....	3
	2.3. Operating Conditions.....	3
	2.3.1. Temperature .....	3
	2.3.2. Humidity .....	4
	2.4. Safety Classification .....	4
	2.4.1. Charger .....	4
	2.4.2. Battery .....	4
	2.5. Power Requirements .....	5
	2.6. Environmental Sealing .....	5
	2.7. Battery Specifications .....	5
	2.8. Dimensions and Weight .....	6
	2.9. Parent Products .....	7
	2.9.1. NAVIC .....	7
	2.9.2. SKOOT .....	7

	2.9.3. SKOOT • X .....	7
	2.9.4. SKOOT • HT .....	7
	2.9.5. MOTIX .....	7
<b>3</b>	<b>Definitions .....</b>	<b>8</b>
	3.1. Safety Symbols .....	8
	3.2. Safety Signal Words .....	9
<b>4</b>	<b>System Components .....</b>	<b>10</b>
	4.1. Component Identification .....	10
	4.2. Battery .....	11
	4.3. Charger.....	11
	4.4. Power Adapter.....	11
<b>5</b>	<b>Operation .....</b>	<b>12</b>
	5.1. Configurations .....	12
	5.1.1. System Connectivity .....	12
	5.2. Charger Procedure .....	13
	5.3. Battery Charge Level Indicator Operation .....	13
	5.4. Charge Status Indicator .....	14
	5.5. Important .....	14
	5.6. Important Charging Notes .....	14
	5.7. Warnings .....	15
	5.7.1. Battery Warnings .....	15
	5.7.2. Safety Instructions For Lithium Ion.....	17
	5.7.3. Charger Warnings .....	17
	5.8. Cautions .....	19
	5.9. Storage .....	20
	5.9.1. Extended Storage .....	20
	5.10. Symbols Used on Equipment .....	20

<b>6</b>	Maintenance .....	<b>21</b>
	6.1. Cleaning .....	21
<b>7</b>	Service and Repair .....	<b>22</b>
	7.1. Technical Support .....	22
<b>8</b>	Spare Parts .....	<b>23</b>
	8.1. Charger .....	23
	8.2. Power Adapter .....	24
	8.2.1. Power Cord Type.....	24
<b>9</b>	Disposal .....	<b>25</b>
<b>10</b>	Limited Warranty .....	<b>26</b>
<b>11</b>	Appendix .....	<b>28</b>
	11.1. Battery Compatibility .....	28

# IDENTIFICATION

## 1.1. Product Brand

This user manual describes the proper safety precautions, setup and use of the battery and charger.

## 1.2. Manufacturer

Distributor:

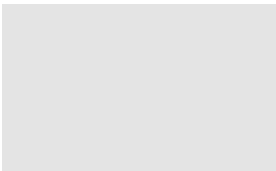

Manufacturer:

Jireh Industries Ltd.  
53158 Range Road 224  
Ardrossan, Alberta, Canada  
T8E 2K4  
780.922.4534  
jireh.com

## 1.3. Compliance Declarations

### 1.3.1. ISED Emissions Compliance (Canada)

CAN ICES-003(A) / NMB-003(A)

This Class A digital apparatus complies with Canadian ICES-003.

*Cet appareil numérique de la classe A est conforme à la norme NMB-003 du Canada.*

### 1.3.2. FCC Suppliers Declaration of Conformity (United States)

This device complies with Part 15 of the FCC Rules. Operation is subject to the following two conditions: (1) this device may not cause harmful interference, and (2) this device must accept any interference received, including interference that may cause undesired operation.

This equipment has been tested and found to comply with the limits for a Class A digital device, pursuant to part 15 of the FCC Rules. These limits are designed to provide reasonable protection against harmful interference when the equipment is operated in a commercial environment. This equipment generates, uses, and can radiate radio frequency energy and, if not installed and used in

accordance with the instruction manual, may cause harmful interference to radio communications. Operation of this equipment in a residential area is likely to cause harmful interference in which case the user will be required to correct the interference at his own expense.

<b>RESPONSIBLE PARTY NAME:</b>	Jireh Industries
<b>ADDRESS:</b>	2955 S Sam Houston Pkwy E Suite 300 Houston, Texas United States 77047
<b>TELEPHONE:</b>	832-564-0626

### 1.3.3. European Union CE Declaration

Jireh Industries hereby declares that the Battery and Charger products complies with the essential requirements and other relevant provisions of the following European Union directives:



- |            |  |
|------------|--|
| 2014/30/EC | EMC Directive  |
| 2014/35/EC | Low Voltage Directive  |
| 2012/19/EU | Directive on Waste Electrical and Electronic Equipment                       |
| 2011/65/EU | Restrictions on Hazardous Substances (RoHS)                                  |
| 2006/66/EC | Directive on Batteries and Accumulators and Waste Batteries and Accumulators |

## PRODUCT SPECIFICATIONS

### 2.1. Intended Use

The battery is a Sealed Lithium Ion (*Li-ion*) battery. The battery is charged by the charger.

The battery and charger are intended to be used by persons who have read and understood this user manual and the associated product user manual.

The charger is intended for indoor use only (*or dry environments*).

### 2.2. Storage Conditions

#### 2.2.1. Humidity

Battery	5%-95%	Non- condensing
Charger	5%-95%	Non- condensing

#### 2.2.2. Temperature

Battery	-25° to 25°C	-13 to 77°F	1 year
	-25° to 40°C	-13 to 104°F	3 months
Charger	-10° to 60°	14° to 140°F	

### 2.3. Operating Conditions

#### 2.3.1. Temperature

Battery	-20° to 60°C	-4° to 140°F	Discharging
	0° to 40°C	32° to 104°F	Charging
Charger	0° to 40°C	32° to 104°F	



### 2.3.2. Humidity

Battery	5%-95%	non- condensing
Charger	5%-95%	non- condensing

## 2.4. Safety Classification

### 2.4.1. Charger

Type of protection against electric shock	Class III
Mode of operation	Continuous
Input	24VDC, 100VA max. (LPS/SELV power source)

### 2.4.2. Battery

Protection against electrical shock	Internally powered
-------------------------------------	--------------------

## 2.5. Power Requirements



**CAUTION!** Do not disconnect under load. Shut off power before connection or disconnecting. Permanent damage to electronics could occur.



Power Requirements: 24VDC, 100VA max. (LPS/SELV power source)

**NOTE:** *The battery and charger automatically adjust to the supplied voltage.*

## 2.6. Environmental Sealing

Dust-tight.

## 2.7. Battery Specifications

Battery 1	18V		5Ah, 90Wh
Battery 2	18V		5Ah, 90Wh

**NOTE:** *For transportation, one DVA001 battery is considered to be two 18V batteries each having a rating of 5Ah, 90Wh. When installed in a system, the two 18V batteries inside the DVA001 are joined together in series for a system voltage of 36VDC with a 5Ah, 180Wh rating.*

## 2.8. Dimensions and Weight

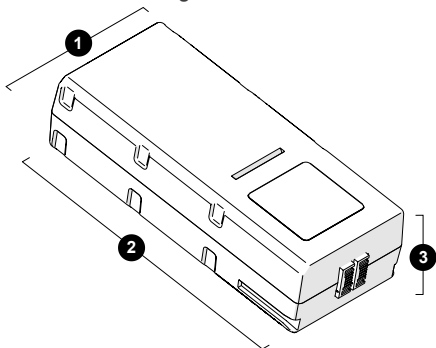

Fig. 1 - Battery dimensions

1:	Width:	8.8 cm	3.5 in
2:	Depth:	21.2 cm	8.4 in
3:	Height:	5.5 cm	2.2 in
4:	Battery weight:	1.4 kg	3 lb

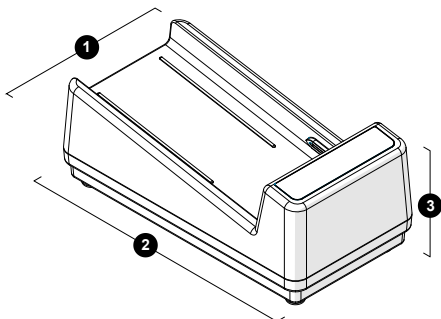

Fig. 2 - Charger dimensions

1:	Width:	11.1 cm	4.4 in
2:	Depth:	21.5 cm	8.5 in
3:	Height:	8.7 cm	3.4 in
4:	Charger weight:	0.4 kg	0.9 lb

## 2.9. Parent Products

The Battery and Charger may be used with the products listed in this section. These products have a User Manual of their own, and shall be referred to for their product specifications. If the use of the Battery and Charger in conjunction with these products modifies the product specifications, those differences are shown here.

### 2.9.1. NAVIC

The NAVIC has a user manual of its own, and shall be referred to for the NAVIC's specifications.

### 2.9.2. SKOOT

The SKOOT has a user manual of its own, and shall be referred to for the SKOOT's specifications.

### 2.9.3. SKOOT•X

The SKOOT•X has a user manual of its own, and shall be referred to for the SKOOT•X's specifications.

### 2.9.4. SKOOT•HT

The SKOOT•HT has a user manual of its own, and shall be referred to for the SKOOT•HT's specifications.

### 2.9.5. MOTIX

The MOTIX has a user manual of its own, and shall be referred to for the MOTIX's specifications.

# DEFINITIONS

### 3.1. Safety Symbols

The following safety symbols might appear on the product and in this document. Read and understand their meaning below:



General  
warning  
symbol

This symbol is used to alert the user to potential hazards. All safety messages that follow this symbol shall be obeyed to avoid possible harm or material damage.

## 3.2. Safety Signal Words

The following safety signal words might appear in this document. Read and understand their meaning below:

### **DANGER!**

The DANGER signal word indicates an imminently hazardous situation. It calls attention to a procedure, practice, or the like that if not correctly performed or adhered to will result in death or serious personal injury. Do not proceed beyond a DANGER signal word until the indicated conditions are fully understood and met.

### **WARNING!**

The WARNING signal word indicates a potentially hazardous situation. It calls attention to a procedure, practice, or the like that if not correctly performed or adhered to could result in death or serious personal injury. Do not proceed beyond a WARNING signal word until the indicated conditions are fully understood and met.

### **CAUTION!**

The CAUTION signal word indicates a potentially hazardous situation. It calls attention to a procedure, practice, or the like that if not correctly performed or adhered to may result in minor or moderate personal injury, material damage, particularly to the product, destruction of part or all of the product, or loss of data. Do not proceed beyond a CAUTION signal word until the indicated conditions are fully understood and met.

# SYSTEM COMPONENTS

## 4.1. Component Identification

The Battery and Charger System contains the following components:

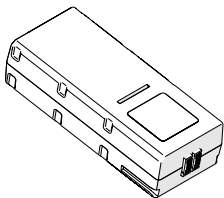

Fig. 3 - Battery  
DVA001

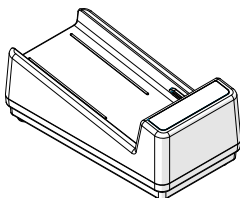

Fig. 4 - Charger  
DVA002

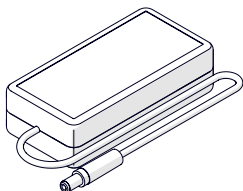

Fig. 5 - Power Adapter  
SK030

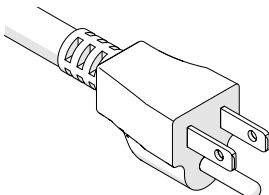

Fig. 6 - Power Cord - North American  
SL032

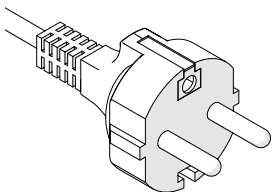

Fig. 7 - Power Cord - European  
SL039

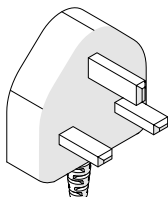

Fig. 8 - Power Cord - United Kingdom  
SL059

## 4.2. Battery

The Battery carries the charge capable of powering various equipment. Indicator lights display the level of charge the battery contains.

## 4.3. Charger

The apparatus for charging the battery. Indicator lights display the current operation of the charger in relation to the battery.

## 4.4. Power Adapter

Various plug designations are available to international users.



## OPERATION

## 5.1. Configurations

## 5.1.1. System Connectivity

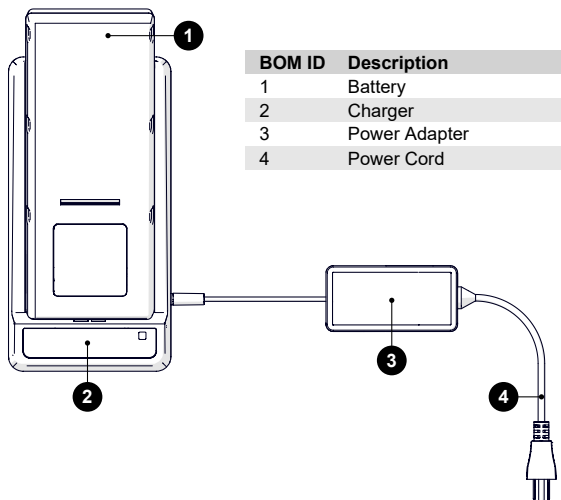





Fig. 9 - Battery and charger system connectivity

## 5.2. Charger Procedure



- ▶ Plug AC adapter into charger.
- ▶ Plug AC adapter into appropriate outlet before inserting battery.
- ▶ Insert battery into charger, ensure battery is fully seated in charger.
- ▶ The Indicator light will blink green continuously, indicating that the charging process is underway.
- ▶ The completion of the charge will be indicated by the solid green light remaining ON continuously. The battery is fully charged and may be used or left in the charger.

## 5.3. Battery Charge Level Indicator Operation

- ▶ Disconnect Battery from charger to verify charge level of battery.
- ▶ Verify charge level of Battery by pressing the status button on the battery.
- ▶ Battery LED indicates the level of charge as follows:

Indicator Light	Visual Cue	Description
	5 Green LED	Indicates a full charge
	3 Green LED	Indicates a half charge
	1 Green LED	Indicates a low charge

## 5.4. Charge Status Indicator

Indicator Light	Visual Cue	Description
	Blinking Green	Battery is charging
	Solid Green	Battery is fully charged
	Solid Red	No battery in charger

## 5.5. Important

- ▶ The battery LEDs will not illuminate while the battery is being charged. To determine the battery charge level via the battery LEDs, the battery must be disconnected from the charger.
- ▶ When the battery is fully discharged, the battery LEDs will not illuminate. Plugging the charger plug into the battery will reset the LEDs. Charge status LEDs will illuminate once the charger is disconnected from the battery.
- ▶ The battery should be fully charged prior to use. The battery should be recharged after each use. The battery may be recharged without being fully discharged.
- ▶ To maintain the battery life, remove the battery from the charger when a full charge is achieved.
- ▶ The battery should be replaced when the battery's green LEDs do not illuminate after a full charge cycle. Damage to charger could occur when continuing to charge the battery when the battery's green LEDs will not illuminate.

## 5.6. Important Charging Notes

1. Longest life and best performance can be obtained if the battery pack is charged when the air temperature is between 18° – 24°C (65 – 75°F). DO NOT charge the battery pack in an air temperature below 0°C (32°F), or above 40°C (104°F). This is important and will prevent serious damage to the battery pack.
2. The charger and battery pack may become warm to the touch while charging. This is a normal condition, and does not indicate a problem. To facilitate the cooling of the battery pack after use, avoid placing the charger or battery pack in a warm environment such as in a metal

shed or an uninsulated trailer.

3. A cold battery pack will charge at about half the rate of a warm battery pack. The battery pack will charge at that slower rate throughout the entire charging cycle and will not return to maximum charge rate even if the battery pack warms.
4. If the battery pack does not charge properly:
  - ▶ Check operation of receptacle by plugging in a lamp or other appliance;
  - ▶ Check to see if receptacle is connected to a light switch which turns power off when you turn out the lights;
  - ▶ Move the charger and battery pack to a location where the surrounding air temperature is approximately 18° – 24°C (65° – 75°F);
5. You may charge a partially used pack whenever you desire with no adverse effect on the battery pack.
6. Foreign materials of a conductive nature such as, but not limited to, grinding dust, metal chips, steel wool, aluminum foil, or any buildup of metallic particles should be kept away from charger cavities. Always unplug the charger from the power supply when there is no battery pack in the cavity. Unplug the charger before attempting to clean.
7. Do not freeze or immerse the charger in water or any other liquid.

## 5.7. Warnings

- ▶ Read and follow all instructions and labeling. Failure to follow instructions, including all warnings and cautions, could lead to misuse of the device or device malfunction.
- ▶ The battery is not fully charged when delivered. Before using the battery and charger, read the safety instructions and follow charging procedures.

### 5.7.1. Battery Warnings

- ▶ Recharge the battery with the charger specified by the manufacturer. *(Consult the chart at the end of this manual for compatibility of batteries and chargers)*

- ▶ No other charger shall be used with the battery:
  - ▶ Charging the battery with another charger could cause damage.
  - ▶ A charger that is suitable for one type of battery pack may create a risk of fire when used with another battery pack.
- ▶ **FIRE HAZARD.** Do not store or carry the battery pack so that metal objects can contact exposed battery terminals. For example, do not place the battery pack in aprons, pockets, tool boxes, product kit boxes, drawers, etc., with loose nails, screws, keys, etc. Transporting batteries can possibly cause fires if the battery terminals inadvertently come in contact with conductive materials such as keys, coins, hand tools and the like. The US Department of Transportation Hazardous Material Regulations (*HMR*) actually prohibit transporting batteries in commerce or on airplanes (e.g., *packed in suitcases and carry-on luggage*) unless they are properly protected from short circuits. So when transporting individual battery packs, make sure that the battery terminals are protected and well insulated from materials that could contact them and cause a short circuit.
- ▶ Do not charge or use the battery pack in explosive atmospheres, such as in the presence of flammable liquids, gases or dust. Inserting or removing the battery pack from the charger may ignite the dust or fumes.
- ▶ Never force the battery pack into the charger. Do not modify the battery pack in any way to fit into a non-compatible charger as battery pack may rupture causing serious personal injury. Consult the chart at the end of this manual for compatibility of batteries and chargers.
- ▶ Charge the battery packs only in designated JIREH chargers.
- ▶ Do not splash or immerse in water or other liquids.
- ▶ For best life store battery packs in a cool, dry location.
- ▶ **FIRE HAZARD.** Never attempt to open the battery pack for any reason. Do not crush, drop or damage the battery pack. Do not use a battery pack or

charger that has received a sharp blow, been dropped, run over or damaged in any way (e.g., *pierced with a nail, hit with a hammer, stepped on*). Damaged batteries should be returned to the service center for recycling (see “*Jireh Industries Ltd.*” on page 1).

### 5.7.2. Safety Instructions For Lithium Ion (Li-Ion)

- ▶ Do not incinerate the battery pack even if it is severely damaged or is completely worn out. The battery pack can explode in a fire. Toxic fumes and materials are created when lithium ion battery packs are burned.
- ▶ If battery contents come into contact with the skin, immediately wash area with mild soap and water. If battery liquid gets into the eye, rinse water over the open eye for 15 minutes or until irritation ceases. If medical attention is needed, the battery electrolyte is composed of a mixture of liquid organic carbonates and lithium salts.
- ▶ Contents of opened battery cells may cause respiratory irritation. Provide fresh air. If symptoms persist, seek medical attention.
- ▶ **BURN HAZARD.** Battery liquid may be flammable if exposed to spark or flame.

### 5.7.3. Charger Warnings

- ▶ Before using the charger, read all instructions and cautionary markings on the charger, battery pack and product using the battery pack.
- ▶ **SHOCK HAZARD.** Do not allow any liquid to get inside the charger. Electric shock may result.
- ▶ **BURN HAZARD.** To reduce the risk of injury, charge only JIREH rechargeable batteries. Other types of batteries may overheat and burst resulting in personal injury and property damage.

**NOTE:** Under certain conditions, with the charger plugged into the power supply, the charger can be shorted by foreign material. Foreign materials of a conductive nature, such as, but not limited to, grinding dust, metal chips, steel wool, aluminum foil or any buildup of metallic particles should be kept away from the charger cavities. Always unplug the charger from the power supply when there is no battery pack in the cavity. Unplug the charger before attempting to clean.

- ▶ Do not attempt to charge the battery pack with any chargers other than the ones in this manual. The charger and battery pack are specifically designed to work together.
- ▶ These chargers are not intended for any uses other than charging JIREH rechargeable batteries. Any other uses may result in risk of fire, electric shock or electrocution.
- ▶ Do not expose the charger to rain or snow.
- ▶ Pull by the plug rather than the cord when disconnecting the charger. This will reduce the risk of damage to the electric plug and cord.
- ▶ Make sure that the cord is located so that it will not be stepped on, tripped over or otherwise subjected to damage or stress.
- ▶ Do not use an extension cord unless it is absolutely necessary. Use of improper extension cord could result in risk of fire, electric shock or electrocution.
- ▶ Do not place any object on top of the charger or place the charger on a soft surface that might block the ventilation slots and result in excessive internal heat. Place the charger in a position away from any heat source. The charger is ventilated through slots in the top and the bottom of the housing.

- ▶ Do not operate the charger with a damaged cord or plug.
- ▶ Do not operate the charger if it has received a sharp blow, been dropped or otherwise damaged in any way. Deliver it to an authorized service center (see *“Jireh Industries Ltd.” on page 1*).

## 5.8. Cautions

- ▶ Do not expose to battery to flame and spark. Do not open, crush or incinerate.
- ▶ Store battery in upright position to avoid Battery damage.
- ▶ The battery charger is only designed for indoor use and should not come into contact with water or dust.
- ▶ The battery and charger have no internal serviceable parts. Any attempt to gain entry into the internal components of the battery and charger will void any warranty claims. Unlawful entry into the product housing can lead to product malfunction.
- ▶ When necessary, cleaning the battery and charger should consist of wiping the external covering of the units with a damp cloth. Do not allow liquids to enter the battery power cable output and/or charger input connector(s).
- ▶ To reduce the risk of injury and damage, never immerse the battery and/or charger in liquid.
- ▶ Follow local governing ordinances and recycling plans regarding disposal or recycling of charger.
- ▶ The battery is a Li-ion battery. Battery must be recycled. For recycling information see WEEE.







## 5.9. Storage

### 5.9.1. Extended Storage

- ▶ To maintain Battery's full charge, it is recommended to place the battery on the charger every 30-60 days for a full charge cycle.
- ▶ The best storage place is one that is cool and dry, away from direct sunlight and excess heat or cold.

**NOTE:** Battery packs should not be stored completely depleted of charge. The battery pack will need to be recharged before use.

## 5.10. Symbols Used on Equipment

Symbol	Symbol Description
	ATTENTION Consult instructions for use
	Polarity for 2.5 mm jack
	Direct Current
	Do not throw in trash (see "Disposal" on page 25)

# MAINTENANCE

### 6.1. Cleaning

Use a damp cloth to clean the Battery and Charger, keeping away from all electrical connectors.

# SERVICE AND REPAIR



**WARNING! DO NOT DISASSEMBLE.** No user-serviceable parts. Disassembling any of the components in this product, beyond the instructions in this user manual, could void the regulatory certifications and/or effect the safety of the product.

## 7.1. Technical Support

For technical support, contact Jireh Industries (see “Jireh Industries Ltd.” on page 1).

**NOTE:** *The Battery and Charger have no serviceable internal parts.*

## SPARE PARTS

To order accessories or replacement parts for your Battery (contact "Jireh Industries Ltd." on page 1).

## 8.1. Charger

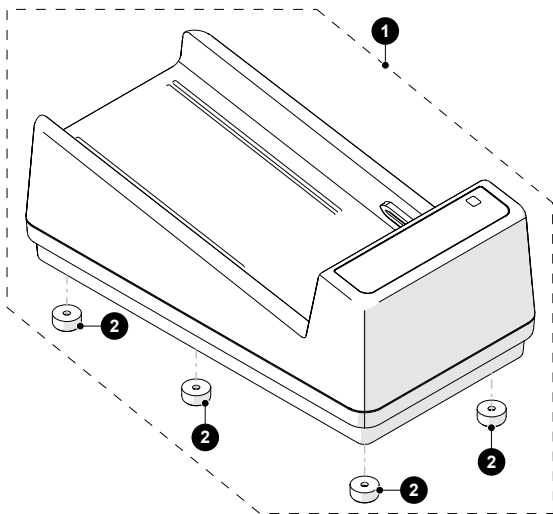

Fig. 10 - Charger

BOM ID	Part #	Description
1	DVA002	Charger
2	EA604	Rubber Standoff

## 8.2. Power Adapter

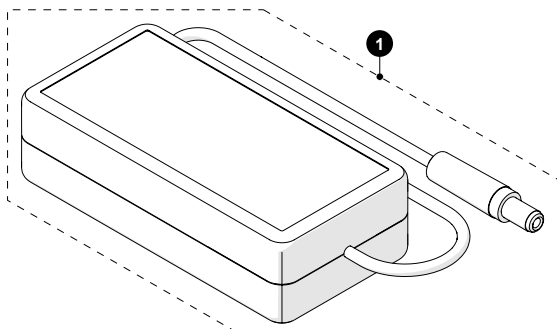
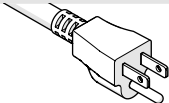
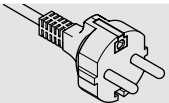
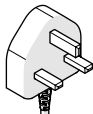

Fig. 11 - Power adapter

BOM ID	Part #	Description
1	SK030	Power Adapter

### 8.2.1. Power Cord Type

Connector Type	Part #	Power Cord	
N	SL032	North American	
E	SL039	European	
U	SL059	United Kingdom	
Z		No Cord	

# DISPOSAL

### WEEE Directive

In accordance with European Directive on Waste Electrical and Electronic Equipment (WEEE), this symbol indicated that the product must not be disposed of as unsorted municipal waste, but should be collected separately. Refer to Jireh Industries for return and/or collection systems available in your country.



# LIMITED WARRANTY

## WARRANTY COVERAGE

Jireh Industries warranty obligations are limited to the terms set forth below: Jireh Industries Ltd. ("Jireh") warrants this hardware product against defects in materials and workmanship for a period of THREE (3) YEARS from the original date of purchase. If a defect exists, at its option Jireh will (1) repair the product at no charge, using new or refurbished replacement parts, (2) exchange the product with a product that is new or which has been manufactured from new or serviceable used parts and is at least functionally equivalent to the original product, or (3) refund the purchase price of the product. A replacement product/part assumes the remaining warranty of the original product or ninety (90) days from the date of replacement or repair, whichever provides longer coverage for you. When a product or part is exchanged, any replacement item becomes your property and the replaced item becomes Jireh's property. When a refund is given, your product becomes Jireh's property.

## OBTAINING WARRANTY SERVICE

To utilize Jireh's warranty service you must ship the product, at your expense, to and from Jireh Industries. Before you deliver your product for warranty service you must phone Jireh and obtain an RMA number. This number will be used to process and track your product. Jireh is not responsible for any damage incurred during transit.

## EXCLUSIONS AND LIMITATIONS

This Limited Warranty applies only to hardware products manufactured by or for Jireh Industries. This warranty does not apply: (a) to damage caused by accident, abuse, misuse, misapplication, or non-Jireh products; (b) to damage caused by service (including upgrades and expansions) performed by anyone who is not a Jireh Authorized Service Provider; (c) to a product or a part that has been modified without the written permission of Jireh.

Jireh Industries Ltd.  
53158 Range Road 224  
Ardrossan AB T8E 2K4  
Canada

Phone: 780-922-4534

[jireh.com](http://jireh.com)

All brands are trademarks or registered trademarks of their respective owners and third-party entities.

Changes or modifications to this unit or accessories not expressly approved by the party responsible for compliance could void the user's authority to operate the equipment.

All specifications are subject to change without notice.

© 2019 - 2022 Jireh Industries Ltd.



## APPENDIX

### 11.1. Battery Compatibility

Battery	Charger
DVA001	DVA002



Jireh Industries Ltd.  
53158 Range Road 224  
Ardrossan, Alberta  
Canada  
T8E 2K4

780-922-4534

[jireh.com](http://jireh.com)