



PREAMP

CX0502 Rev 00.5
UT Preamplifier

SAFETY WARNINGS / PRECAUTIONS

KEEP THIS MANUAL – DO NOT LOSE

THIS MANUAL IS PART OF THE **PREAMP** SYSTEM AND MUST BE RETAINED FOR THE LIFE OF THE PRODUCT. PASS ON TO SUBSEQUENT OWNERS.

Ensure any amendments are incorporated with this document.



CAUTION! The Preamp is designed for a specific use. Using the Preamp outside of its intended use is dangerous. Failure to comply with the warnings, instructions, and specifications in this manual could result in **PERSONAL INJURY** or **EQUIPMENT DAMAGE**. Read and understand this manual before using.



WARNING! DO NOT DISASSEMBLE. No user-serviceable parts. Disassembling any of the components in this product, beyond the instructions in this user manual, could void the regulatory certifications and/or effect the safety of the product.



The WEEE symbol indicates that the product must not be disposed of as unsorted municipal waste, but should be collected separately.

(see “Disposal” on page 23 for additional details).

TABLE OF CONTENTS

1	Identification	1
	1.1. Product Brand	1
	1.2. Manufacturer	1
	1.3. Compliance Declarations	1
	1.3.1. ISED Emissions Compliance (Canada).....	1
	1.3.2. FCC Suppliers Declaration of Conformity (United States).....	1
	1.3.3. European Union CE Declarations	2
	1.3.4. UKCA Declarations	3

2	Product Specifications	4
	2.1. Base Preamp System	4
	2.1.1. Intended Use	4
	2.1.1.1 User	4
	2.1.1.2 Operating Environment	4
	2.1.2. Dimensions and Weight	5
	2.1.3. Power Requirements	5
	2.1.4. Environmental Sealing	6
	2.1.5. Performance Specifications	6
	2.2. Parent Products	6
	2.2.1. NAVIC	6

3	Definitions	7
	3.1. Definition of Symbols	7

	3.2. Safety Signal Words	8
4	System Components	9
	4.1. Component Identification	9
	4.2. Parent Products	10
	4.3. Preamp	11
	4.4. UT Cable.....	12
	4.5. Preamp Case	12
5	Preparation For Use	13
	5.1. Standard Configuration	13
	5.2. NAVIC with corrosion thickness probe holder ..14	
	5.2.1. Preamp Installation	15
6	Operation	16
	6.1. Activating Preamp	16
	6.2. Changing the GAIN	16
	6.3. Turning off the Preamp	16
	6.4. Low Battery Indicator	17
	6.5. Battery Replacement	18
7	Maintenance	19
	7.1. Maintenance Schedule	19
	7.2. Cleaning	19
8	Troubleshooting	20
9	Service and Repair	21
	9.1. Technical Support	21

10	Spare Parts	22
	10.1. Preamp.....	22
11	Disposal	23
12	Limited Warranty	24

IDENTIFICATION

1.1. Product Brand

This user manual describes the proper safety precautions, setup and use of the Preamp.

1.2. Manufacturer

Distributor:

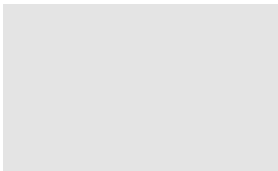

Manufacturer:

Jireh Industries Ltd.
53158 Range Road 224
Ardrossan, Alberta, Canada
T8E 2K4
780.922.4534
jireh.com

1.3. Compliance Declarations

1.3.1. ISED Emissions Compliance (Canada)

CAN ICES-003(A) / NMB-003(A)

This Class A digital apparatus complies with Canadian ICES-003.

Cet appareil numérique de la classe A est conforme à la norme NMB-003 du Canada.

1.3.2. FCC Suppliers Declaration of Conformity (United States)

This device complies with Part 15 of the FCC Rules. Operation is subject to the following two conditions: (1) this device may not cause harmful interference, and (2) this device must accept any interference received, including interference that may cause undesired operation.

This equipment has been tested and found to comply with the limits for a Class A digital device, pursuant to part 15 of the FCC Rules. These limits are designed to provide reasonable protection against harmful interference when the equipment is operated in a commercial environment. This equipment generates, uses, and can radiate radio frequency energy and, if not installed and used in

accordance with the instruction manual, may cause harmful interference to radio communications. Operation of this equipment in a residential area is likely to cause harmful interference in which case the user will be required to correct the interference at his own expense.

**RESPONSIBLE
PARTY NAME:**

Jireh Industries

ADDRESS:

2955 S Sam Houston Pkwy E
Suite 300
Houston, Texas
United States 77047

TELEPHONE:

832-564-0626

1.3.3. European Union CE Declarations

Jireh Industries hereby declares that the Preamp product complies with the essential requirements and other relevant provisions of the following European Union directives:



- 2014/30/EU EMC Directive
- 2014/35/EU Low Voltage Directive
- 2012/19/EU Directive on Waste Electrical and Electronic Equipment
- 2011/65/EU Directive on Restriction of Hazardous Substances (RoHS)

1.3.4. UKCA Declarations

Jireh Industries hereby declares that the Preamp product complies with the essential requirements and other relevant provisions of the following UK directives.



Title	Edition/ Date of Issue
Electromagnetic Compatibility Regulations	2016
Electrical Equipment (Safety) Regulations	2016
Waste Electrical and Electronic Equipment Regulations	2013
Restriction of the Use of Certain Hazardous Substances in Electrical and Electronic Equipment Regulations	2012

PRODUCT SPECIFICATIONS

2.1. Base Preamp System

2.1.1. Intended Use

The Preamp is used to amplify the return signal from an ultrasonic transducer and improve the signal-to-noise ratio for transmission over long cables. It is intended for use with the Parent Products and their limits listed in Section 2.2 (see “Parent Products” on page 6) but can also be used as a standalone device in any applicable ultrasonic testing scenario.

2.1.1.1 User

The Preamp is intended to be used by persons who have read and understand this user manual as well as the user manual of the relevant Parent Products.

2.1.1.2 Operating Environment

The Preamp is for use in industrial environments having ambient temperatures shown below. It is NOT intended for use in explosive environments.

Category	Parameter	Specification
Environment	Minimum ambient temperature	-20°C (-4°F)
	Maximum ambient temperature	50°C (122°F)

2.1.2. Dimensions and Weight

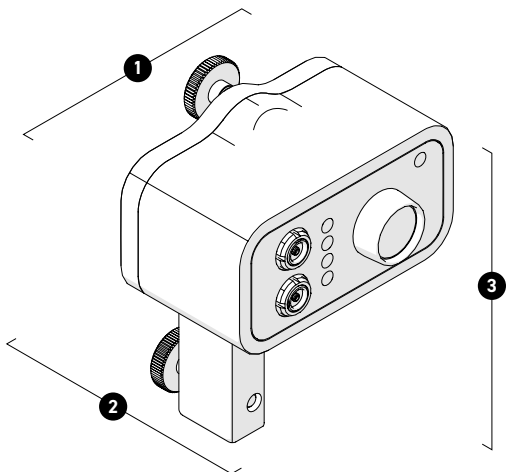

Fig. 1 - Preamp dimensions

1:	Width:	7.2 cm	2.8 in
2:	Depth:	5.4 cm	2.1 in
3:	Height:	9 cm	3.5 in
4:	Preamp weight:*	218 g	7.69 oz

*With 9V battery installed.

2.1.3. Power Requirements

Power requirements:	Single 9V NEDA 1604 Battery (Alkaline or lithium recommended)
---------------------	--

2.1.4. Environmental Sealing

Dust-tight, watertight (*not submersible*).

2.1.5. Performance Specifications

Gain	Selectable (30dB, 40dB, 50dB, 60dB)
Bandwidth	30 kHz to 30 MHz
Output Impedance	50 Ω
Output Voltage	4 V _{pk-pk} into 50 Ω Load
Battery Life	8-12 Hours Continuous Use with Standard Alkaline 9V Battery

2.2. Parent Products

When the Preamp is used with one of the Parent Products listed in this section and if the Preamp's use modifies the product specifications (*i.e. intended use, power requirements, etc.*) of the Parent Product, the modifications are shown here. The specifications listed here supersede those of the Parent Products. If no specifications are listed here, the specifications of the Parent Products remain effective.

These Parent Products have a user manual of their own, and shall be referred to for their product specifications.

2.2.1. NAVIC CXG023-

The NAVIC has a user manual of its own, and shall be referred to for the NAVIC'S specifications. The use of the Preamp with the NAVIC does not modify the NAVIC specifications.

The Preamp is intended to be used by persons who have read and understand this user manual as well as, when applicable, the user manual of the relevant Parent Products.

DEFINITIONS

3.1. Definition of Symbols



Instructions to 'look here' or to 'see this part'.

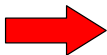

Denotes movement. Instructing users to carry out an action in a specified direction.

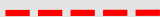

Indicates alignment axis.



Alerts users that the view has changed to a reverse angle.

3.2. Safety Signal Words

The following safety signal words might appear in this document. Read and understand their meaning below:

DANGER!

The DANGER signal word indicates an imminently hazardous situation. It calls attention to a procedure, practice, or the like that if not correctly performed or adhered to will result in death or serious personal injury. Do not proceed beyond a DANGER signal word until the indicated conditions are fully understood and met.

WARNING!

The WARNING signal word indicates a potentially hazardous situation. It calls attention to a procedure, practice, or the like that if not correctly performed or adhered to could result in death or serious personal injury. Do not proceed beyond a WARNING signal word until the indicated conditions are fully understood and met.

CAUTION!

The CAUTION signal word indicates a potentially hazardous situation. It calls attention to a procedure, practice, or the like that if not correctly performed or adhered to may result in minor or moderate personal injury, material damage, particularly to the product, destruction of part or all of the product, or loss of data. Do not proceed beyond a CAUTION signal word until the indicated conditions are fully understood and met.

SYSTEM COMPONENTS

4.1. Component Identification

The Preamp contains the following components:

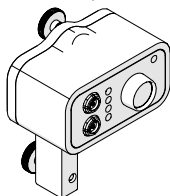

Fig. 2 - Preamp
CXA032

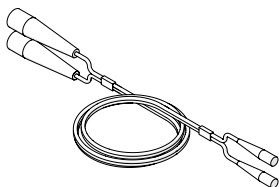

Fig. 3 - Dual BNC male to 10-32 male: 30 m (98.5 ft)
SL037

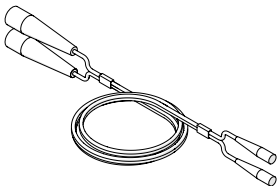

Fig. 4 - Dual BNC male to 10-32 male: 15 m (49.2 ft)
SL048

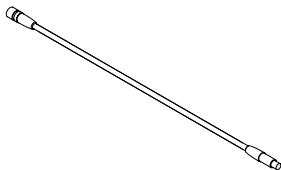

Fig. 5 - LEMO 00 male to 10-32 male: 0.6 m (2 ft)
SL053

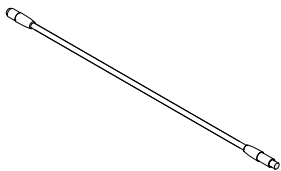

Fig. 6 - LEMO 00 male to 10-32 female: 0.6 m (2 ft)
SL052

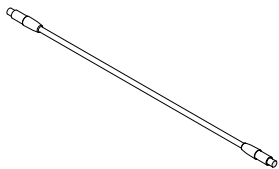

Fig. 7 - LEMO 00 male to LEMO 00 male: 0.6 m (2 ft)
SL067

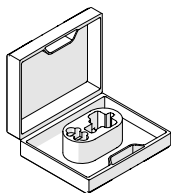

Fig. 8 - Preamp Case
CXA041

4.2. Parent Products

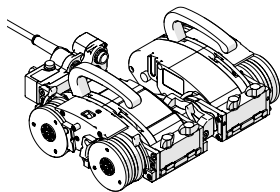

Fig. 9 - NAVIC system
CXG023-

4.3. Preamp

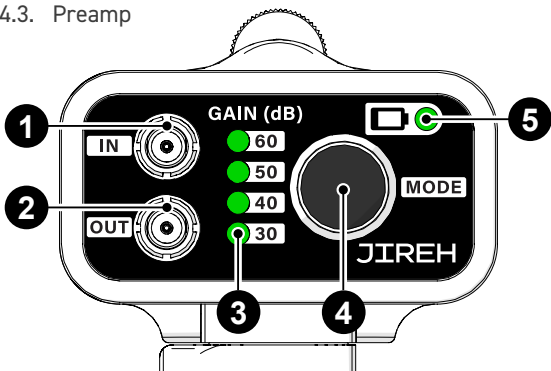

Fig. 10 - Preamp

The Preamp amplifies ultrasonic signals to improve the signal-to-noise ratio for transmission over long cables. The preamp is placed near the probe in the return path from the probe to the instrument.

1	In connector	Connects to probe output.
2	Out connector	Connects to the instrument input.
3	Gain indicator	Lights illuminate to show the current gain setting.
4	Mode button	Press to turn the preamp on and change the gain setting. Hold to turn preamp off.
5	Low battery indicator	Battery replacement is recommended when the light illuminates.

4.4. UT Cable

Various lengths of UT (*ultrasonic testing*) cable are included with the kit.

Cable	Length
Dual BNC male to 10-32 male	30 m (98.5 ft)
Dual BNC male to 10-32 male	15 m (49.2 ft)
LEMO 00 male to 10-32 male	0.6 m (2 ft)
LEMO 00 male to 10-32 female,	0.6 m (2 ft)
LEMO 00 male to LEMO 00 male,	0.6 m (2 ft)

4.5. Preamp Case

The product includes a fitted case for all the components of this system.

PREPARATION FOR USE

NOTE: Avoid plugging the cable from the instrument into the Preamp output. A possible electrical surge to the Preamp may occur.

5.1. Standard Configuration

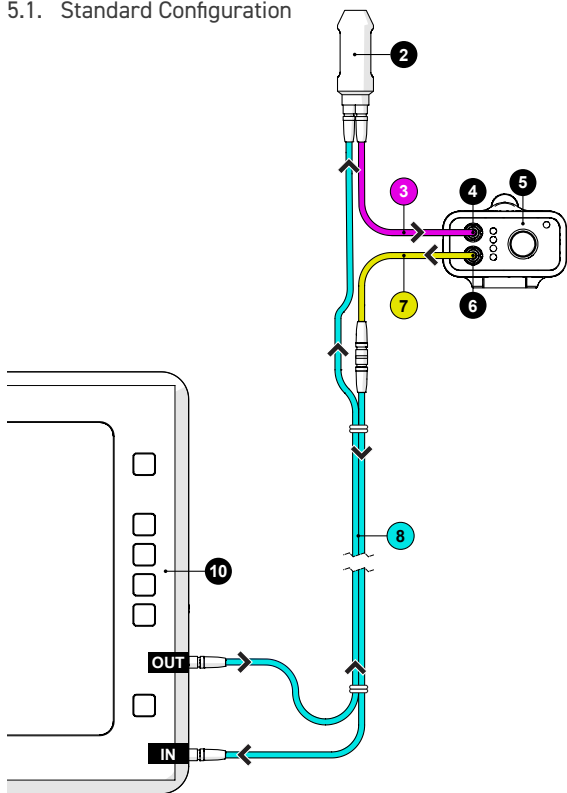

Fig. 11 - Standard preamp configuration

BOM ID	Description
1	Probe Holder
2	Probe
3	LEMO 00 male to 10-32 male
4	In Connector
5	Preamp
6	Out Connector
7	LEMO 00 male to 10-32 female
8	Dual BNC male to 10-32 male
9	NAVIC
10	User's Instrument

Fig. 12 - Component configuration

5.2. NAVIC with corrosion thickness probe holder

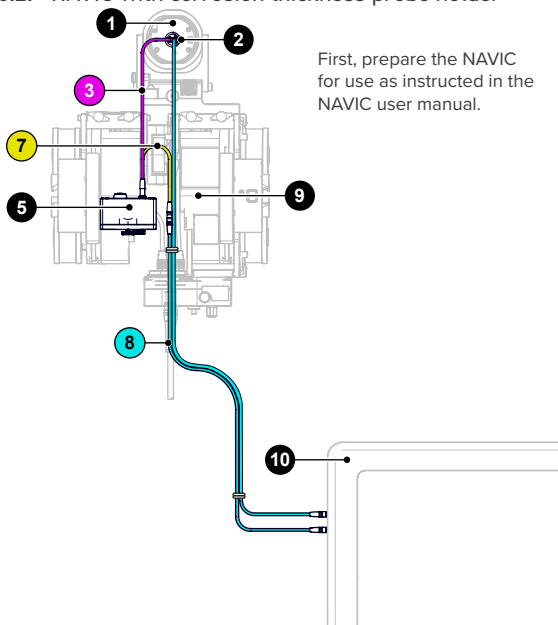

Fig. 13 - Preamp mounted to a NAVIC system

5.2.1. Preamp Installation

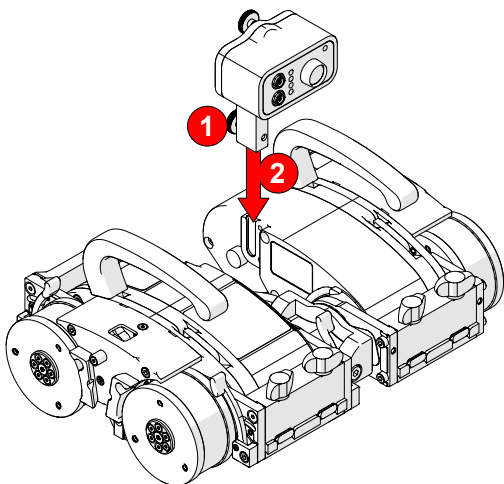

Fig. 14 - Mount preamp to the dove-tail accessory mount

1. Loosen the knob of the preamp mounting bracket **1** (Fig. 14).
2. Align the preamp's mounting bracket with the NAVIC's dove-tail accessory mount **2** (Fig. 14).

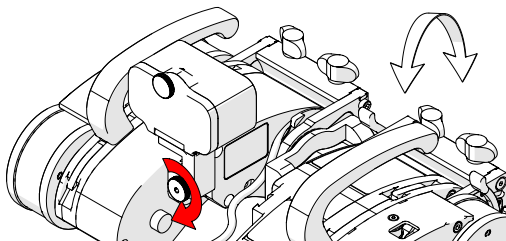

Fig. 15 - Tighten the preamp mounting bracket knob

3. Tighten the preamp's mounting bracket knob (Fig. 15).

OPERATION

6.1. Activating Preamp

1. Press the Mode Button to activate the preamp (*Fig. 16*).
2. The GAIN setting last selected will become illuminated, indicating the preamp has been turned on (*Fig. 17*).
3. After 5 seconds, the selected GAIN setting LED will begin blinking. (*a measure to increase battery life*)

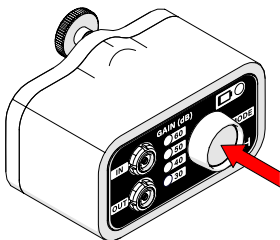

Fig. 16 - Press the mode button to activate

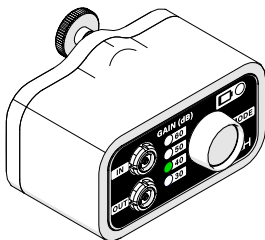

Fig. 17 - GAIN light illuminates when power is on

TIP: When the battery has been replaced, the GAIN setting resets to 30 dB.

6.2. Changing the GAIN

1. Press the Mode button to alternate between various GAIN settings (*Fig. 16*).

TIP: When the preamp GAIN setting blinks, an initial press of the power button is required to activate the GAIN selection mode.

6.3. Turning off the Preamp

1. Press and hold the mode button until the indicator lights turn off. This confirms that the preamp has been deactivated (*Fig. 16*).

6.4. Low Battery Indicator

The low battery indicator light illuminates when the battery is near the end of its useful life. The preamp will continue to function, but replacement of the battery is recommended.

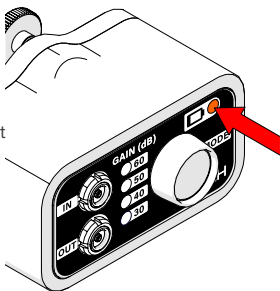

Fig. 18 - Low battery indicator

6.5. Battery Replacement

1. Unscrew the knob of the battery compartment (Fig. 19).
2. Remove the 9V battery from the battery compartment and dispose of it according to local regulations (Fig. 20).

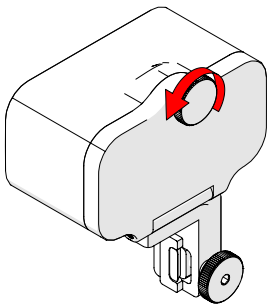

Fig. 19 - Unscrew battery door knob

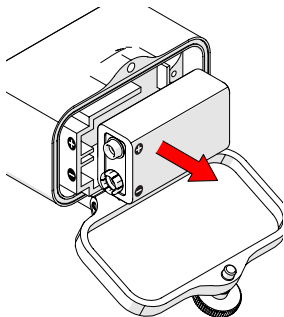

Fig. 20 - Remove the 9V battery

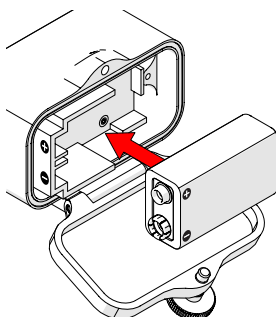

Fig. 21 - Place 9V battery in housing

3. Place the new 9V NEDA 1604 battery into the battery compartment. Ensure the polarity markers match (Fig. 21).
4. Close the battery compartment and tighten the knob (Fig. 22).

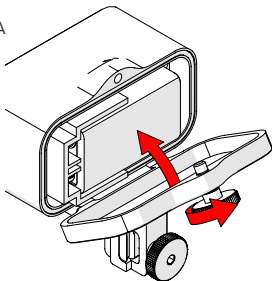

Fig. 22 - Close battery compartment

MAINTENANCE

7.1. Maintenance Schedule

Task	Frequency
<u>Inspect cables and connectors</u> Inspect the Preamp cables for damage. Have any damaged cable repaired by a qualified person or replace the cable assembly as necessary. <ul style="list-style-type: none"> Inspect all connectors for damage or moisture. Dry connectors before using. 	Every use
<u>General cleaning</u> Ensure that the Preamp stays relatively clean by wiping off any excess dirt or other contaminants after every use.	Every use

7.2. Cleaning

General cleaning of components is important to keep your system working well. All components that have no wiring or cables are waterproof. Components can be washed with warm water, dish soap and a medium bristle brush.

Before using the preamp, ensure all connectors are free of water and moisture.

Inspect cables/connectors daily and as required, depending on the occurrence of damaging events.

NOTE: All components with wiring, cables or electrical connections are splashproof. However, these components are **NOT** submersible.

NOTE: Never use strong solvents or abrasive materials to clean your preamp components.

TROUBLESHOOTING

Problem	Possible Cause	Solution
Preamp will not turn on.	Battery is dead.	Replace battery with a new 9V battery. (see “Low Battery Indicator” on page 17).
	Battery has been installed in the preamp incorrectly.	Ensure the polarity markers of the battery match those of the preamp’s battery compartment. (see “Low Battery Indicator” on page 17).
No signal is being received by the instrument.	Preamp is off.	Turn on preamp (see “Activating Preamp” on page 16).
	Incorrect cable connections.	Ensure cables are correctly routed to appropriate equipment (see “Standard Configuration” on page 13).
	Internal failure.	Remove the preamp from the signal path and connect the probe directly to the instrument. Verify probe signal is present on the instrument. Should failure continue, contact Jireh Industries for repair (see “Technical Support” on page 21).

SERVICE AND REPAIR



WARNING! DO NOT DISASSEMBLE. No user-serviceable parts. Disassembling any of the components in this product, beyond the instructions in this user manual, could void the regulatory certifications and/or effect the safety of the product.

There are no user-serviceable components inside the preamp. Do NOT open the housing or attempt any repairs. For issues with your preamp, first, consult “Troubleshooting” (see “*Troubleshooting*” on page 20) and then “Technical Support” (see “*Technical Support*” on page 21).

9.1. Technical Support

For technical support, contact Jireh Industries (see “*Jireh Industries Ltd.*” on page 1)

SPARE PARTS

To order accessories or replacement parts for the Preamp (contact Jireh Industries Ltd. on page 1).

NOTE: These drawings are for parts order. This is not a list of kit contents.

10.1. Preamp

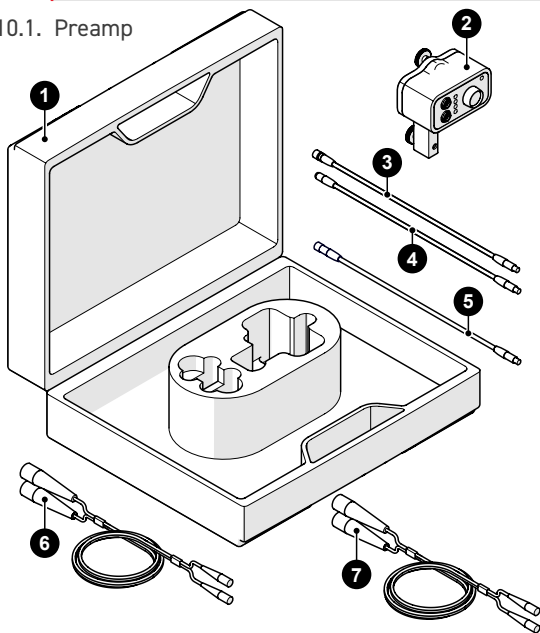

BOM ID	Part #	Description
1	CXA041	Preamp Case
2	CXA032	Preamp
3	SL053	LEMO 00 male to 10-32 male: 0.6 m (2 ft)
4	SL052	LEMO 00 male to 10-32 female: 0.6 m (2 ft)
5	SL067	LEMO 00 male to LEMO 00 male: 0.6 m (2 ft)
6	SL037	Dual BNC male to 10-32 male: 30 m (98.5 ft)
7	SL048	Dual BNC male to 10-32 male: 15 m (49.2 ft)

Fig. 23 - Preamp parts

DISPOSAL

WEEE Directive

In accordance with European Directive on Waste Electrical and Electronic Equipment (WEEE), this symbol indicated that the product must not be disposed of as unsorted municipal waste, but should be collected separately. Refer to Jireh Industries for return and/or collection systems available in your country.



LIMITED WARRANTY

WARRANTY COVERAGE

Jireh Industries warranty obligations are limited to the terms set forth below: Jireh Industries Ltd. (“Jireh”) warrants this hardware product against defects in materials and workmanship for a period of THREE (3) YEARS from the original date of purchase. If a defect exists, at its option Jireh will (1) repair the product at no charge, using new or refurbished replacement parts, (2) exchange the product with a product that is new or which has been manufactured from new or serviceable used parts and is at least functionally equivalent to the original product, or (3) refund the purchase price of the product. A replacement product/part assumes the remaining warranty of the original product or ninety (90) days from the date of replacement or repair, whichever provides longer coverage for you. When a product or part is exchanged, any replacement item becomes your property and the replaced item becomes Jireh’s property. When a refund is given, your product becomes Jireh’s property.

OBTAINING WARRANTY SERVICE

To utilize Jireh’s warranty service you must ship the product, at your expense, to and from Jireh Industries. Before you deliver your product for warranty service you must phone Jireh and obtain an RMA number. This number will be used to process and track your product. Jireh is not responsible for any damage incurred during transit.

EXCLUSIONS AND LIMITATIONS

This Limited Warranty applies only to hardware products manufactured by or for Jireh Industries. This warranty does not apply: (a) to damage caused by accident, abuse, misuse, misapplication, or non-Jireh products; (b) to damage caused by service (including upgrades and expansions) performed by anyone who is not a Jireh Authorized Service Provider; (c) to a product or a part that has been modified without the written permission of Jireh.

Jireh Industries Ltd.
53158 Range Road 224
Ardrossan AB T8E 2K4
Canada

Phone: 780-922-4534

jireh.com

All brands are trademarks or registered trademarks of their respective owners and third-party entities.

Changes or modifications to this unit or accessories not expressly approved by the party responsible for compliance could void the user's authority to operate the equipment.

All specifications are subject to change without notice.

© 2020-2022 Jireh Industries Ltd.



Jireh Industries Ltd.
53158 Range Road 224
Ardrossan, Alberta
Canada
T8E 2K4

780-922-4534

jireh.com